

# locktronics

Simplifying Electricity

**Electricity matters 2**



LK7326

**MATRIX**  
[www.matrixmultimedia.com](http://www.matrixmultimedia.com)

Copyright © 2009 Matrix Multimedia Limited

# Contents

## Electricity matters 2

Worksheet 1 - Circuit symbols	3
Worksheet 2 - Conductors	4
Worksheet 3 - Resistors	8
Worksheet 4 - Series and parallel	10
Worksheet 5 - Measuring current	12
Worksheet 6 - Measuring voltage	14
Worksheet 7 - Ohm's law	16
Worksheet 8 - LEDs and diodes	19
Worksheet 9 - LDRs and thermistors	22
Worksheet 10 - Voltage dividers	24
Worksheet 11 - Variable resistors	26
Worksheet 12 - Electrical power	28
Quiz	31
Teachers' notes	34
Student handout	41

Developed by John Verrill in conjunction with Matrix Multimedia Limited

# Worksheet 1

## Circuit symbols

# Electricity matters

## 2



Everyday you come across **symbols**, used at home or when you are out and about. They are quicker to read than long messages using words!

Circuit symbols describe which components are used in a circuit, and show how they are connected.

A circuit might look like this -

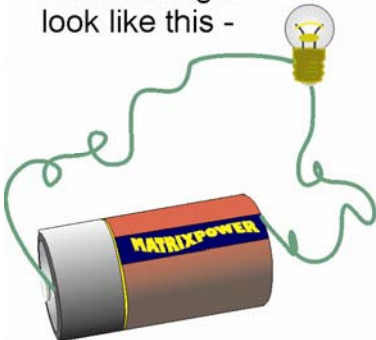

It is simpler to use symbols -

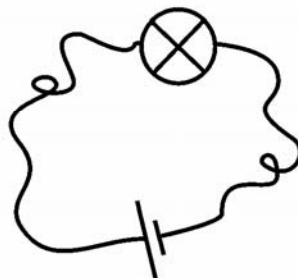

Or better still -

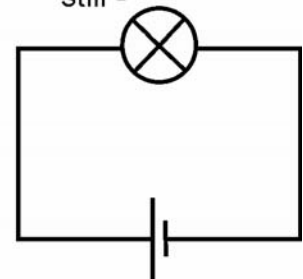

w1k

Look at the two circuits, A and B. Compare them. Are they the same?

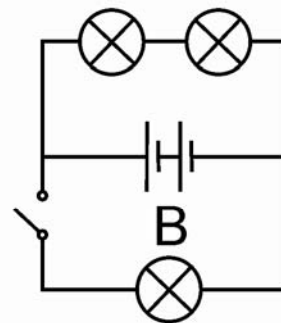
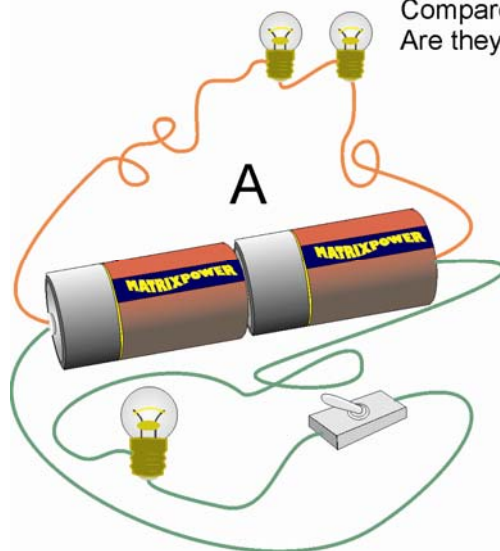

w1l

# Worksheet 1

## Circuit symbols

# Electricity matters

## 2

**Over to you:**

1. Here are four circuits, shown using symbols and also as 'real' layouts. Build each one and work out the answers to the questions.

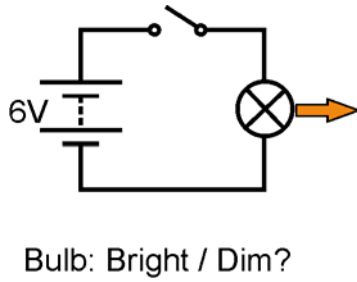

w1a

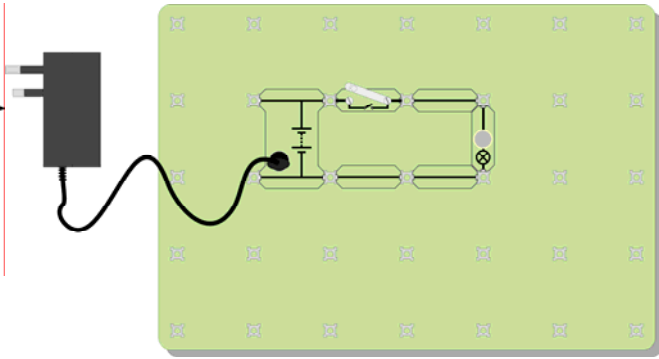

w1b

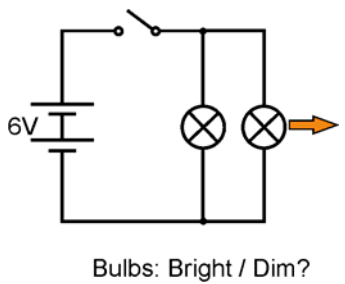

w1c

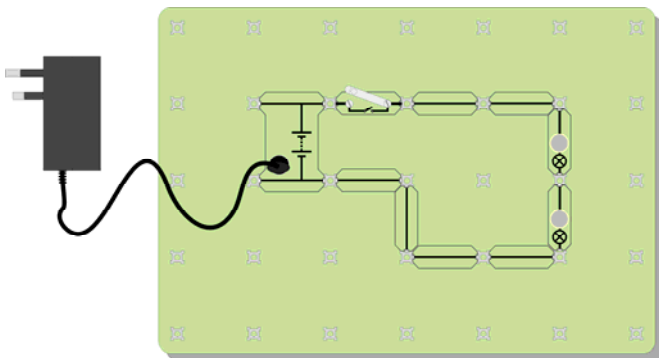

w1d

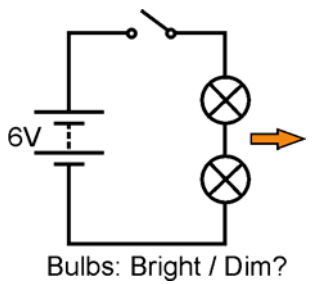

w1e

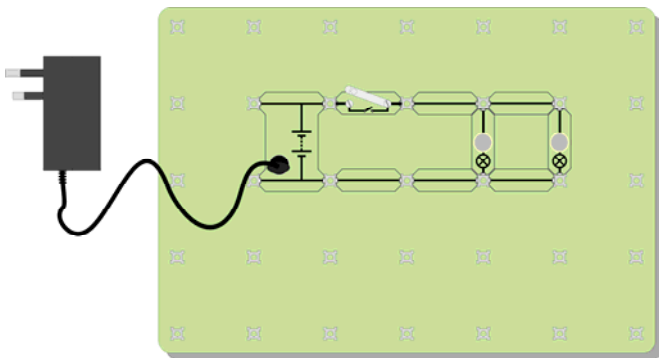

w1f

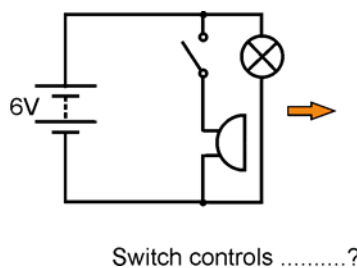

w1g

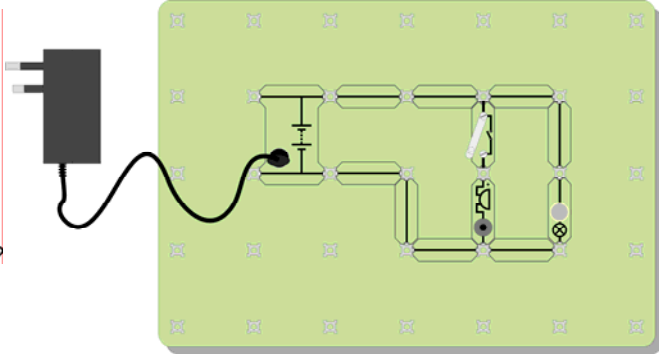

w1h

# Worksheet 1

## Circuit symbols

# Electricity matters

## 2

**So what?**

It is much quicker and easier to describe what is in a circuit by drawing a diagram using symbols, but you must use standard symbols that everyone understands.



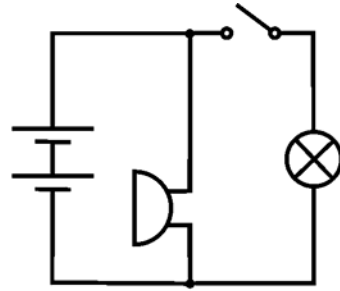

Here is another circuit.  
Build it just using the circuit diagram, and then answer the question!

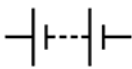
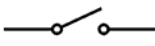

Now the switch controls .....?

w11

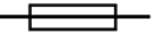
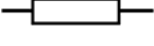
**For your records:**  
Copy the following table:

					
Battery	Toggle switch	Lamp	Fuse	Resistor	Sounder
supplies electrical energy	allows a circuit to work	turns electricity into light	a safety device	controls the size of the current	turns electricity into sound

w11

# Worksheet 2

## Conductors

# Electricity matters

## 2

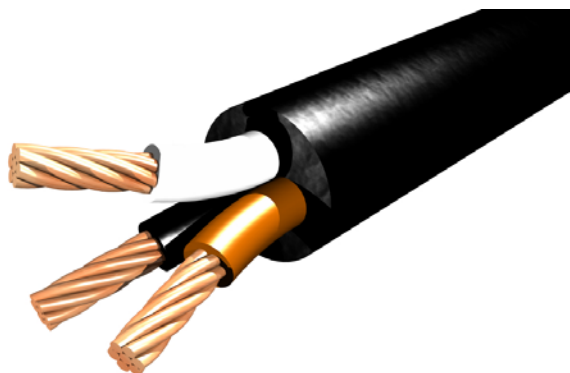

We are surrounded by many kinds of materials. They all behave in different ways. One way in which they are different is that some pass electricity, and others do not.

Materials which pass electricity are called **conductors**.  
Materials which do not pass electricity are called **insulators**.

### Over to you:

1. First of all, build a circuit that makes a bulb light. This is simply to test that all the components work.
2. Swap one link for the carrier with the test gap. This arrangement is shown in the circuit diagram.
3. Put different materials across the gap.
4. See if the bulb lights.
5. Try the following:  
kitchen foil (aluminium), a rubber, paper, wood, polythene, copper, air, lead, glass, pencil lead (graphite), a coin, a piece of cloth, a plastic pen, and any other handy items.
  1. Sort the materials into two groups – **conductors** and **insulators**.
  2. Fill in a table, like the one opposite, with the findings from your experiment.

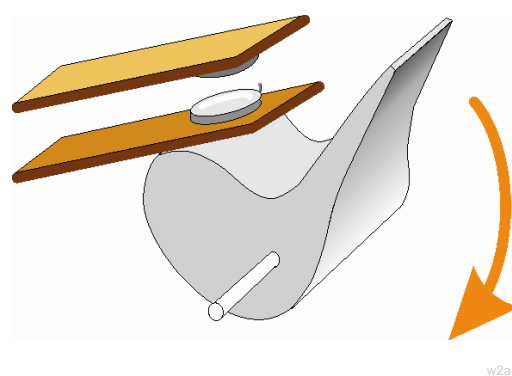
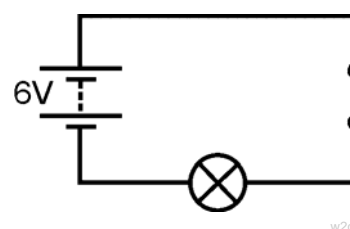

<i><b>Materials that conduct</b></i>	<i><b>Materials that insulate</b></i>

### So what?

- Look at the materials that let electricity pass.
- Which class of substance they all belong to?
- Think of a way to test whether water is a conductor or an insulator. Check your idea with the teacher, and if you get the go-ahead, try your idea out.
- Test pure water, tap water (which is not the same thing!) and salty water. Is there a difference?

# Worksheet 2

## Conductors

# Electricity matters

## 2

### Switches:

We usually need something to activate our electrical circuits. A switch does just that! It relies on the fact that air is an insulator. The diagram shows what happens inside a switch when you press the lever down to switch it on.

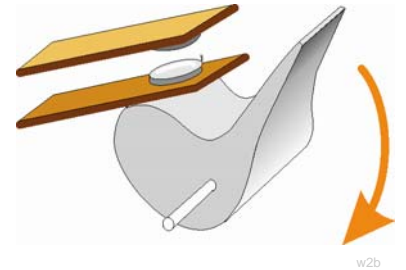

w2b

### Over to you:

1. Set up the arrangement shown in the circuit diagram.
2. Change the circuit so that there are two bulbs in it, and the switch controls both bulbs. Now change the circuit again so that the switch controls only one bulb.

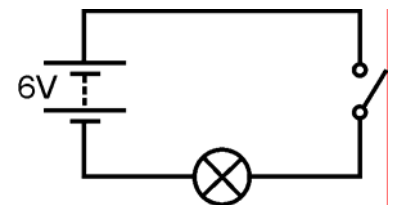

w2d

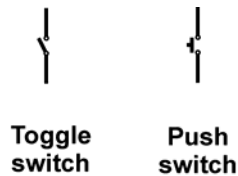

Here are the names and symbols for two types of switch: A **push switch** is 'on' only as long as you are pressing it. When you turn on a **toggle switch**, it stays on, until you turn it off.

### For your records:

- Most of the conductors belong to the class of substances called .....
- I think that the hard shiny object that felt cold would ..... electricity, because it is probably made of a .....
- Pure water is an ..... However, if there are any impurities in it, such as salt, or chlorine, then the water is a .....
- Air is an ..... which explains why we do not get an electric shock when we stand near a mains electricity socket. A switch starts and stops the flow of .....
- When the switch is open, the ..... gap stops the flow of electricity.
- When the switch is ....., the air gap disappears, and electricity flows around the circuit.
- A toggle switch stays on or stays off all the time. A push switch is on only as long as you press it.
- A doorbell is one type of ..... switch. A light switch is one type of ..... switch.

# Worksheet 3

## Resistors

## Electricity matters

### 2



w3000006361865Small

Using a tap, we can change the flow of water from fast to slow. With electricity, we change the flow using a resistor.

Electric currents can cause a variety of effects – heating, lighting, magnetism and chemical.

Although we cannot see them, tiny particles called electrons make up electric currents. The flow of these electrons can be reduced by adding more resistance to the circuit.

The effect of resistance is like you trying to run in mud!

### Over to you:

1. Make your own resistor by clamping a piece of thin pencil lead (a mixture of carbon and clay,) between the terminal posts as shown.
2. Set up the following circuit. Make sure that the power supply is set to 6V! Close the switch and notice how bright the bulb looks. Remember – the brighter the bulb, the greater the current flowing.
3. Next, swap your pencil lead resistor for one of the connecting links. Close the switch again. What do you notice about the bulb? What does this tell you about the electric current?



w3b

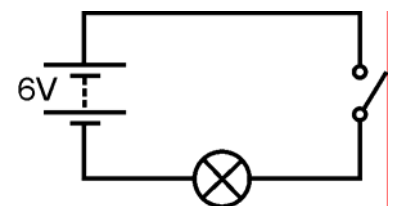

w3c

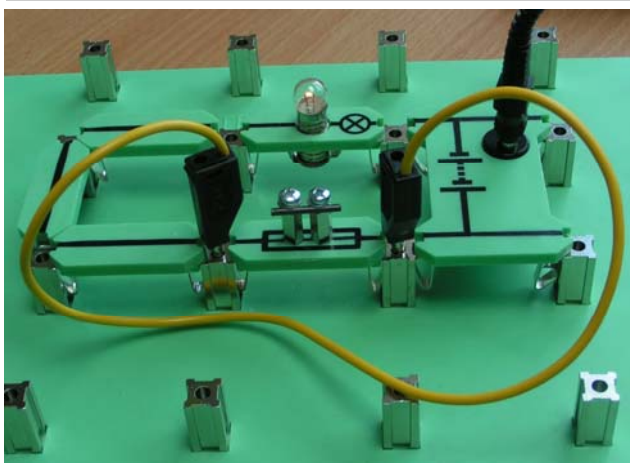

w3g

(To check the effect of the resistor, try 'short-circuiting' it, by plugging in a wire into both ends, as shown in the picture.)

# Worksheet 3

## Resistors

## Electricity matters

### 2

#### Over to you:

1. Now set up the circuit shown in the diagram.
2. Close the switch.
3. What do you notice about the brightness of the two bulbs compared to the brightness of the one bulb in the first circuit (before you added your resistor.)

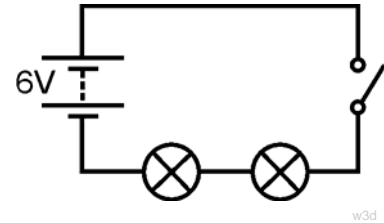

#### So what?

- Adding more resistance to a circuit makes the electric current smaller.
- It is not only 'resistors' that have resistance – pencil lead, bulbs, even the wires themselves and the power supply have some resistance.
- Swap one of the bulbs for a 12 ohm resistor.

Here is the symbol for a resistor.



The circuit diagram for your new arrangement is:

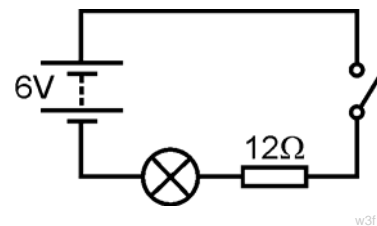

Notice the brightness of the remaining bulb. What does this tell you about bulbs? (Once again, try 'short-circuiting' your resistor, by plugging in a wire into both ends, to check what is happening.)

- **A good question** – where does the 'extra' electric current go when you add a resistor? Think about the flow of other things, like water, or traffic. When you turn a tap down a little to lower the flow of water, where has the 'missing' flow of water gone? When a car breaks down on a busy road, the flow of traffic is reduced. Where is the 'missing' flow of cars?

#### For your records:

- A resistor limits the flow of electricity
- The bigger the resistance, the smaller the electric current.
- Resistance is measured in ohms. Usually, we use the  $\Omega$  sign to mean 'ohms'.

A resistor can be simply a long piece of wire, made from a metal that does not conduct very well. This kind is usually wound as a coil around an insulating core. It can also be made by coating an insulating core with a thin layer of carbon, or by mixing carbon with a ceramic substance (like clay.)

# Worksheet 4

## Series and parallel

# Electricity matters

## 2

In some circuits, there is only one route that the electric current can follow to get from one side of the power supply to the other.

In others, the current has a choice of route.

An electric current is a flow of negatively charged electrons. Overcrowded on the negative terminal of the battery, they flow around the circuit attracted to the positive terminal.

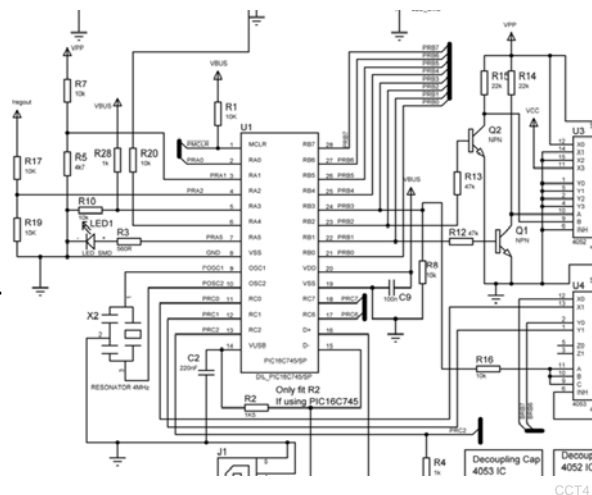

CCT4

A **series** circuit offers only one route around the circuit, from one end of the battery back to the other! There are no junctions in a series circuit.

A **parallel** circuit offers more than one route and so different currents can flow in different parts of the circuit.

### Over to you:

1. Set up the arrangement shown.
2. Make sure that the power supply is set to 9V!
3. This is a series circuit—everything connected in a line, one after the other.
4. There is only one way for electric current to get from one end of the power supply to the other. There are no junctions, no alternative routes!
5. Does it matter where you connect the switch? Try it in different places in the circuit.
6. Close the switch and notice how bright the bulbs look.
7. Don't forget – the brighter the bulb, the greater the current flowing.
8. Unscrew one of the bulbs and notice the effect. Does it matter which bulb you unscrew?
9. Does it look as if electric current is getting 'used up' as it goes round the circuit? (In other words, do the bulbs get dimmer as you move further round the circuit?)
10. If the bulbs have the same brightness, then the current flowing through them must be the same.

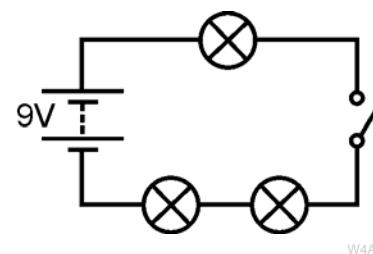

W4A

# Worksheet 4

## Series and parallel

## Electricity matters

### 2

**Over to you:**

1. Now change the circuit for the one shown. Make sure that you set the power supply to 6V!

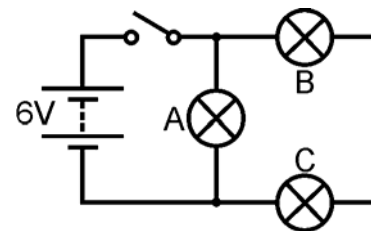

W4B

This is not a series circuit — there are **two** ways to get from one end of the power supply to the other!

Trace these routes out for yourself. (The blobs above and below bulb A mark the junctions in the circuit.)

Look at the brightness of the three bulbs. What does this tell us? Unscrew bulb A. What happens? Unscrew bulb B. What happens?

**So what?**

- One route goes through only one bulb. The other route goes through two bulbs. That route is twice as difficult for the electrons. Most will take the easy route through just the one bulb. More electrons per second = bigger current. Explain to your partner or your teacher how your observations support this idea.
- The second circuit is not a series circuit as there are two ways to get from one side of the battery to the other. Bulb A is connected in parallel with the other two bulbs. Bulb B is in series with bulb C because they are on the same route.
- **A challenge!** Change the circuit so that the switch controls only bulbs B and C, **BUT** you can only move bulb A to achieve this.

**For your records:**

- A series circuit offers only one route for the electric current.
- If a break appears anywhere in the circuit, then the electric current stops everywhere.
- If one bulb fails in the circuit, then all the bulbs go out.
- The electric current is the same size throughout the circuit.
- A parallel circuit offers more than one route and so different currents can flow in different parts of the circuit.
- Copy the circuit diagram and answer these questions:
  1. Bulb B is in series with bulb .....
  2. Bulb C is in ..... with bulb E and bulb F.
  3. Bulbs B and D are in ..... with bulbs C, E and F.
  4. The biggest current will flow through bulb .....
  5. Bulb ..... will be the brightest bulb.

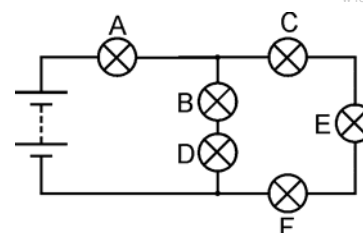

W4C

# Worksheet 5

## Measuring current

## Electricity matters

### 2



So far we have used the brightness of the bulbs as a measure of the size of the current.

This is too crude for a number of reasons:

- Bulbs are mass-produced and so not identical;
- It is difficult to judge small changes in brightness when the currents are similar;
- It doesn't work if the current is too small to light the bulb!

A much more reliable way of measuring current is to use an ammeter. We also need ways of measuring voltage and resistance.

### Meter symbols

Ammeter	
Voltmeter	
Ohmmeter	

w5b



A multimeter offers a convenient and cheap way to measure important electrical quantities such as current, voltage and resistance. The photograph shows the controls on a typical multimeter.



w5a

### Using a multimeter to measure current:

A multimeter can measure either AC or DC quantities. The following symbols are used to distinguish between the two:

AC   
 DC 

- Plug one wire into the black COM socket.
- Plug another into the red mA socket.
- Select the 200mA DC range by turning the dial to the '200m' mark next to the 'A  ' symbol.
- Break the circuit where you want to measure the current, by removing a link, and then plug the two wires in its place.
- Press the red ON/OFF switch when you are ready to take a reading.

### A possible problem!

The ammeter range is protected by a fuse located inside the body of the multimeter. This fuse may have 'blown', in which case the ammeter range will not work. Report any problems to your teacher so that they can check the fuse.

# Worksheet 5

## Measuring current

# Electricity matters

## 2

### Over to you:

1. Set up the arrangement shown. Make sure that the power supply is set to 9V! This is a series circuit. There is only one route for electric current around the circuit.
2. Measure the current flowing at point P. To do this, plug the wires from the ammeter into the two posts at either end of the link at point P, and then remove the link. This is shown in the picture.
3. Now replace the link at P. Measure the current at point Q in the same way.
4. Measure the current at points R and S in the same way.

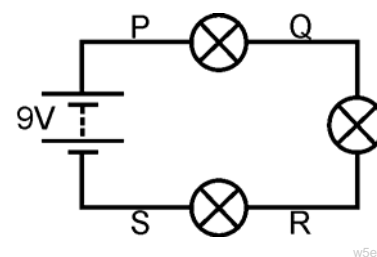

### So what?

Next investigate the currents flowing at points P, Q, R etc. in the following circuits.

Notice the power supply voltage is different for each!

See if you can spot a pattern for the behaviour!

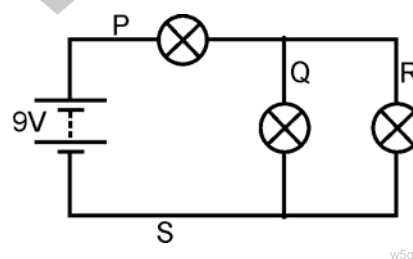
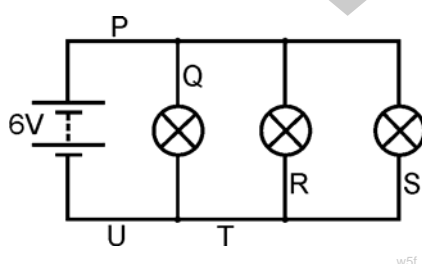

### For your records:

- In a series circuit, the ..... current flows in all parts.
- In a parallel circuit, the currents in all the parallel branches add up to the current leaving the .....
- Copy the following circuit diagrams, and calculate the readings on ammeters A to H.

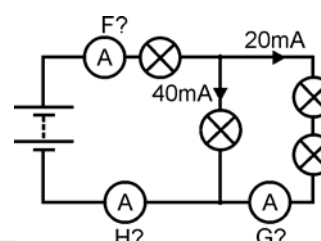
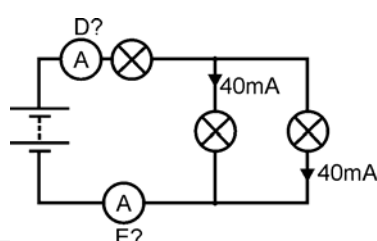
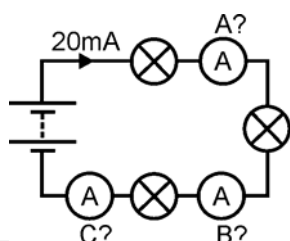

# Worksheet 6

## Measuring voltage



## Electricity matters

### 2

We can visualise electric current reasonably easy—it's the flow of tiny electrons around the circuit. More precisely, current measures the number of electrons per second passing a particular point in the circuit.

It is more difficult to picture voltage. It is a measure of the force that makes the electrons squeeze along the wires. The bigger the power supply voltage, the more energy the electrons are given, and then give up, as they travel around the circuit. However, it is easier to measure voltage than current. No need to break the circuit—just add the voltmeter in parallel with the component you are interested in!



#### Meter symbols

Ammeter	
Voltmeter	
Ohmmeter	

w5b

Ammeters are connected in series whereas voltmeters are connected in parallel!

#### Using a multimeter to measure voltage:

A multimeter can measure either AC or DC quantities. The following symbols are used to distinguish between the two: AC  DC 

- Plug one wire into the black COM socket.
- Plug another into the red V socket.
- Select the 20V DC range by turning the dial to the '20' mark next to the 'V  ' symbol. (It is good practice to set the meter on a range that is much higher than the reading you are expecting. Then you can refine the measurement by choosing a lower range that suits the voltage you find.)
- Plug the two wires into the sockets at the ends of the component under investigation.
- Press the red ON/OFF switch when you are ready to take a reading.
- If you see a '-' sign in front of the reading, it means that the wires from the voltmeter are connected the wrong way round. Swap them over to get rid of it!



w5a

# Worksheet 6

## Measuring voltage

# Electricity matters

## 2

**Over to you:**

1. Set up the arrangement shown (without the voltmeters). Make sure that the power supply is set to 9V! This is a series circuit—there is only one route around it.
2. Measure the voltage across the first bulb, by connecting the voltmeter as shown at P. To do this, plug the wires from the voltmeter into the two posts at either end of the first bulb, as shown in the picture.
3. Next, measure the voltage across the second bulb, shown by connecting the voltmeter as shown at Q.
4. Then measure the voltage across the the third bulb, by connecting the voltmeter at point R.

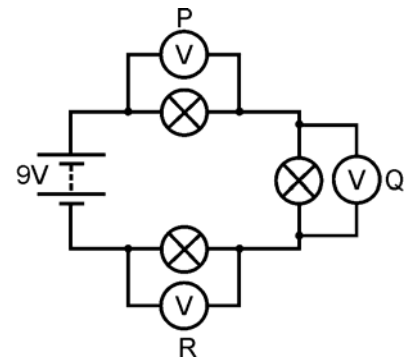

w6c



w6j

**So what?**

Add together the readings of the voltmeters at points P, Q and R. What do you notice about this total? Next investigate the voltages across bulbs P, Q, and R in the following circuits. Notice the power supply voltage is different for each! See if you can spot a pattern for the behaviour.

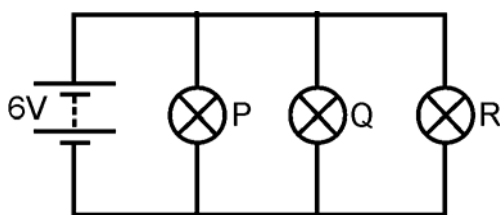

w6d

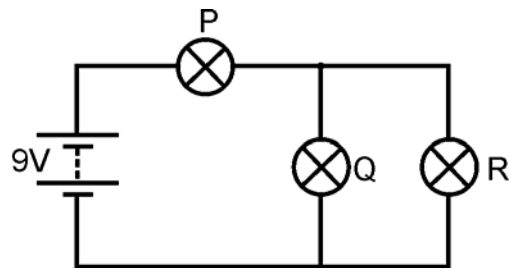

w6e

**For your records:**

- In a series circuit, the voltages across the components add up to the voltage across the .....
- In a parallel circuit, the components all have the ..... voltage across them.
- Copy the following circuit diagrams, and calculate the voltages across bulbs A to E.

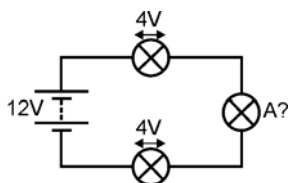

w6f

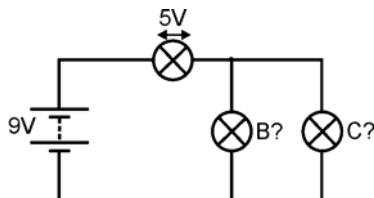

w6g

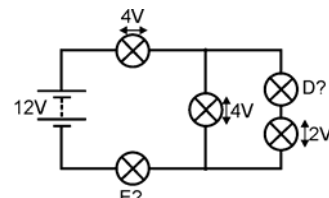

w6h

# Worksheet 7

## Ohm's law

# Electricity matters

## 2

Current measures how many electrons pass per second. Voltage is a measure of how much energy the electrons gain or lose as they flow around a circuit. Resistance shows how difficult it is for the electrons to pass through a material. In squeezing through, the electrons lose energy to the resistor, which warms up as a result.

The photograph shows Georg Simon Ohm—a significant figure in this study!



w7000003785427Small

Ohm's law leads to a very important relationship in electricity:  $V = I \times R$

### Over to you:

1. Set up the arrangement shown in the circuit diagram. **Make sure that the power supply is set to 3V!** The variable resistor allows us to change the voltage across the  $12\Omega$  resistor. The picture shows one way to set this up.
2. **Before you switch on**, select the **200mA DC** range on the ammeter, and the **20V DC** range on the voltmeter. Notice the positions of the red and black connecting wires. This ensures that the meters are connected the right way round to avoid '-' signs on the readings.
3. Turn the knob on the variable resistor fully anti-clockwise, to set the voltage supplied to a minimum.
4. Turn the knob slowly clockwise until the voltage across the resistor reaches 0.1V. Then read the current flowing through the resistor.
5. Turn the voltage up to 0.2V, and take the current reading again.
6. Keep doing this until the voltage reaches 1.0V. **(Don't go past this or the resistor may over-heat.)**
7. Write your results in a table like the one opposite.

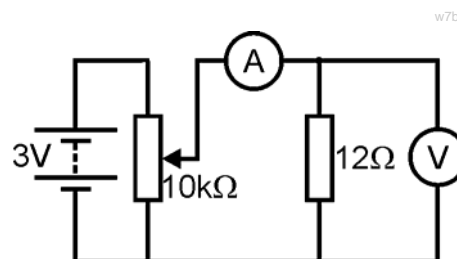

w7b

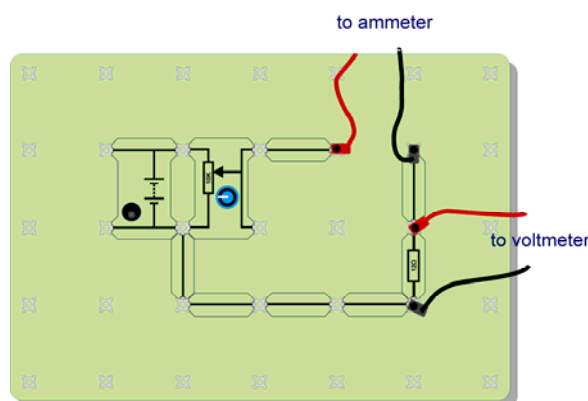

w7c

<b><i>Voltage across resistor</i></b>	<b><i>Current through resistor</i></b>
0.1V	
0.2V	

# Worksheet 7

## Ohm's law

# Electricity matters

## 2

### So what?

Plot a graph to show your results. Ohm's law predicts a straight line, so draw the best straight line through your points. If you know how, calculate the gradient of your graph. Ohm's law calls this quantity the resistance of the resistor.

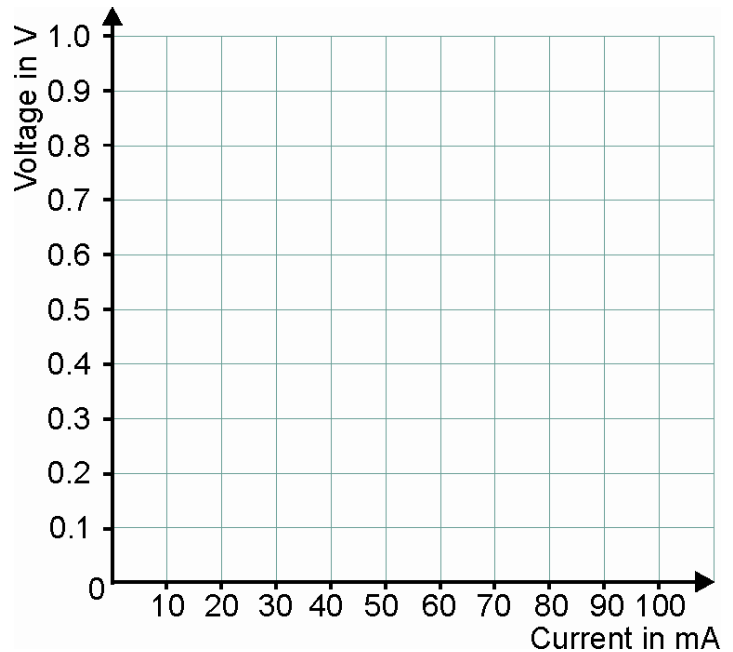

w7d

Black	Brown	Red	Orange	Yellow	Green	Blue	Purple	Grey	White
0	1	2	3	4	5	6	7	8	9

### Resistor Colour Code:

Resistors often come with coloured bands across their body to show the value of the resistance. Each colour represents a number, as shown in the table.

To read the colour code, start from the opposite end to the gold or silver band:

Write down the number shown by the first colour band, and then the second colour band.

Add the number of 0's shown in the next band (e.g for red, add two 0's.)

The final band (usually gold, (5%) or silver (10%)) shows you the tolerance (how accurately made it is.)

For example, the resistors in the photograph has a resistance of:

7 (purple) 5 (green) 000 (orange) =  $75000\Omega$  and a tolerance of 5%

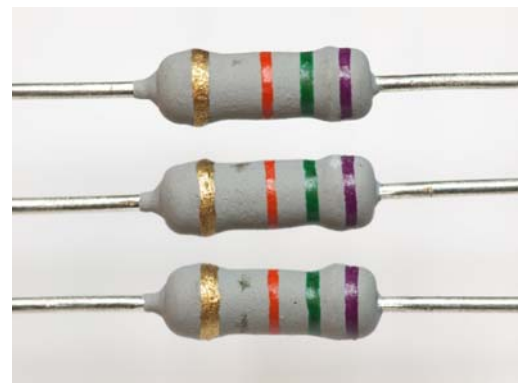

w7b000008827797Small

# Worksheet 7

## Ohm's law

# Electricity matters

## 2

### Using a multimeter to measure resistance:

You cannot measure the resistance of a component while it is in the circuit. It must be removed first.

- Plug one wire into the black COM socket, and the other into the V Ω socket.
- Select the 200kΩ range, (or a range which is much higher than the reading you are expecting.)
- Plug the two wires into the sockets at the ends of the component under investigation.
- Press the red ON/OFF switch when you are ready to take a reading.
- Turn the dial to choose a lower range, until you find the reading.



### Note

1 kΩ = 1000Ω.

### For your records:

- Ohm's law gives us the following equations:  $V = I \times R$   $R = V / I$   $I = V / R$   
 where  $R$  = resistance in ohms,  $I$  = current in amps and  $V$  = voltage.  
 (This also works when the resistance is in kilohms and the current in milliamps, because the kilo (thousands) and milli (thousandths) cancel out.)
- Copy the following diagrams, and calculate the missing quantities:

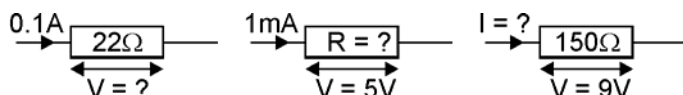

- The resistor colour code is used to show the resistance of a resistor.
- Copy the colour code table given above, and use it to complete the following table:

Band 1	Band 2	Band 3	Resistance
Brown	Black	Yellow	
Green	Blue	Red	
Grey	Red	Black	

# Worksheet 8

## LEDs and diodes

# Electricity matters

## 2

We have just seen that a resistor behaves in a very straight forward way—double the current through it, and you double the voltage across it; quarter the current through it and you quarter the voltage across it, and so on. This result is known as Ohm’s law.

Very few components behave in this way. Here is one that does **not**—the diode.

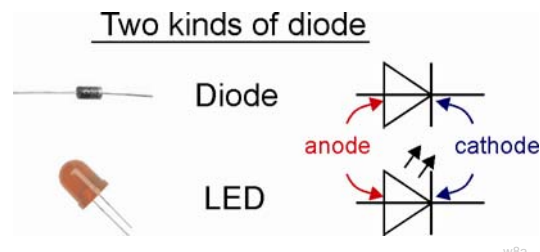

There are two common forms of diode - the power diode, widely used in power supply circuits, and the light-emitting diode (LED), commonly used as an indicator.

**Over to you:**

1. Set up the arrangement shown in the circuit diagram. **Make sure that the power supply is set to 3V!** The variable resistor allows us to change the applied voltage. Set up like this, with the anode connected to the positive end of the power supply, we say that the diode is **forward-biased**.
2. **Before you switch on**, select the **200mA DC** range on the ammeter, and the **20V DC** range on the voltmeter.
3. Turn the knob on the variable resistor fully anti-clockwise, to set the supply voltage to zero.
4. Turn the knob slowly clockwise until the current through the diode reaches 2.0mA. Then read the voltage across the diode.
5. Turn the current up to 4.0mA, and take the voltage reading again. The current will change rapidly for a tiny change in voltage. **Be careful - turn the knob on the variable resistor very gently!**
6. Keep increasing the current in 2mA steps, up to 20mA, taking the voltage reading each time. Write your results in a table like the one shown.

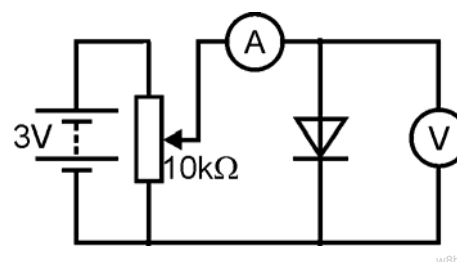

On a diode the cathode is marked by a line on the body of the diode.



On an LED the cathode is the shorter lead

<b>Current through diode</b>	<b>Voltage across diode</b>
2.0mA	
4.0mA	



# Worksheet 8

## LEDs and diodes

## Electricity matters

### 2

#### Over to you:

1. Plot a graph to show your results.
2. Draw a smooth curve, like the one shown, using your plotted points as a guide.
3. Now, turn the voltage down to zero, and switch off the power supply.
4. Remove the diode from the circuit, and replace it the other way round. We say that the diode is now **reverse-biased**.
5. Switch on the power supply.
6. Turn the knob on the variable resistor slowly, and increase the supply voltage to its maximum value. Notice the current reading on the ammeter as you do so! (No need to plot this on a graph!)

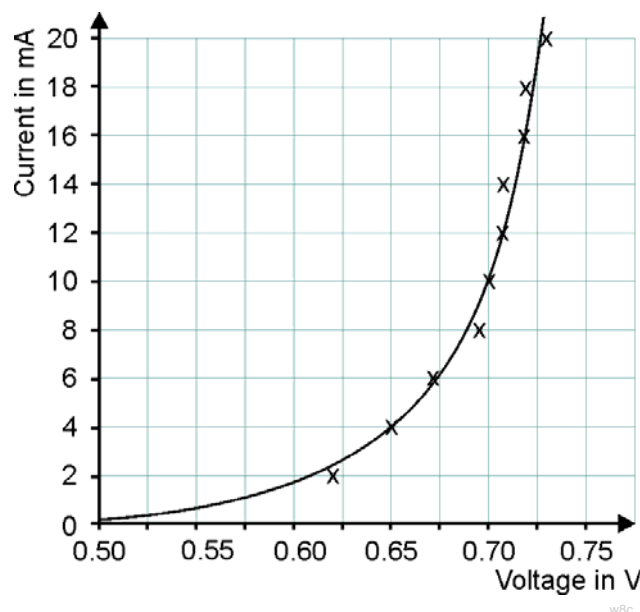

#### So what?

The diode is a 'one-way valve'. It allows a current to flow through it in only one direction. (A resistor does exactly the same thing whichever way you connect it. Try it !) When it is forward-biased, it conducts, with a voltage drop of about 0.7V across it. When it is reverse-biased, it does not conduct (for low voltages.) Next you are going to carry out the same investigation but using a light-emitting diode (LED.)

Look underneath the 5V LED component . It has a  $470\Omega$  resistor connected in series with it, to protect it from high currents.

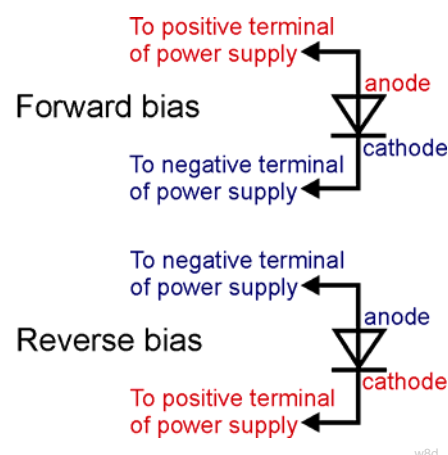

#### Over to you:

1. Using the same circuit as before, plug in the LED so that it is forward biased. Repeat the investigation, but this time increase the current in 0.2mA steps, to a maximum of 2.0mA.
2. Measure the voltage across the LED at each step and plot a graph to show your results.
3. Draw a smooth curve, with the same shape as before, using your points as a guide. Connect the LED the other way round, so that it is reverse-biased, and check its behaviour.

# Worksheet 8

## LEDs and diodes

## Electricity matters

### 2

#### For your records:

- Copy the following diagram showing the symbols for diodes and LEDs:
- The diode is a 'one-way valve'. It allows current to flow through it in only one direction. It conducts when it is forward-biased, and does not when reverse-biased. When it conducts, there is a voltage drop of about 0.7V across it.
- Copy the diagram that shows the difference between forward and reverse bias.
- The light-emitting diode (LED) behaves in the same way. It lights up when forward biased, and the current reaches about 10mA. It then has a voltage drop of about 2V across it.
- It needs to be protected from high currents by connecting a resistor in series.

#### Two diode symbols

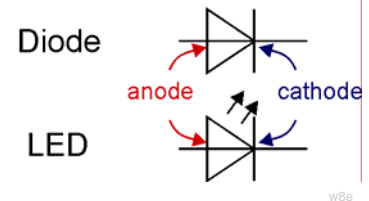

# Worksheet 9

## LDRs and thermistors

## Electricity matters

### 2

This investigation focuses on two very useful types of resistor, the light-dependent resistor (LDR) and the thermistor, which could be called a temperature-dependent resistor.

We will use them as the basis for light sensing and temperature sensing units, by combining them into voltage divider circuits.

### Two useful resistors

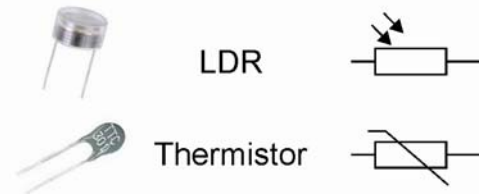

w9a

LDRs and thermistors play an important role in sensing circuits that allow us to control a wide range of industrial and domestic systems.

### Over to you:

The aim of the first part is to measure the resistance of a thermistor at different temperatures. This is done by lowering into a beaker of hot water. The resistance of the thermistor, and the temperature of the water, are measured. You then add cold water to lower the temperature, and the measurements are taken again. This process is repeated a number of times.

1. Use an ohmmeter to measure the resistance of the thermistor. Before you switch it on, set the ohmmeter to the 20k range, and connect the thermistor to it using the COM and  $V\Omega$  sockets.
2. Water temperature is measured either with a mercury-in-glass thermometer, or with a temperature probe connected to a suitable meter or data logger. Set up the arrangement shown in the diagram. (The diagram shows the separate thermistor / moisture sensor unit, but you could use one of the thermistors mounted on a component carrier.) Stir the water gently to make sure that the thermistor and thermometer/probe are at the same temperature.

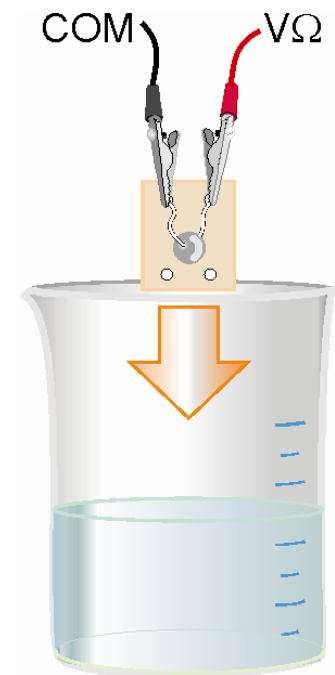

w9b

**Take care when handling hot water! Use heat-resistant gloves to hold the beaker while you pour in hot water from a kettle, or similar heating device! Do not put the clips in the water.**

# Worksheet 9

## LDRs and thermistors

# Electricity matters

## 2

### Over to you:

1. When the readings are steady, measure the resistance and temperature.
2. Write your results in a table like the one shown opposite.
3. Plot a graph to show your results. Choose suitable scales to match the range of your readings.
4. Draw a smooth curve, using your plotted points as a guide.

Temp in °C	Resistance in kΩ

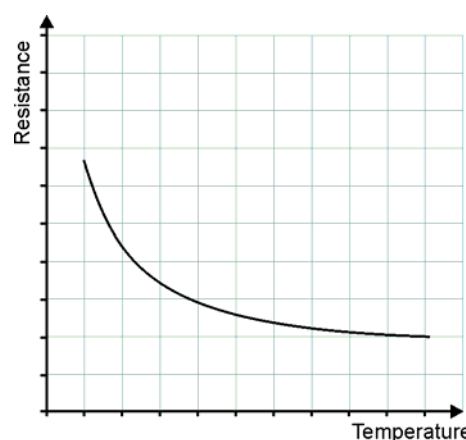

### So what?

As the temperature drops, the resistance of the thermistor increases. This kind of thermistor is called NTC (negative temperature coefficient.) You can buy PTC (positive temperature coefficient.) thermistors, in which the resistance drops when the temperature drops, and in which the resistance rises as the temperature rises.

### A challenge!

Design an experiment to investigate how the resistance of a LDR changes when the intensity of the light falling on it changes. You will need a way to produce different intensities of light, and a way to measure that. The LDR must be shielded from other sources of light.

### For your records:

- Copy the following diagram:

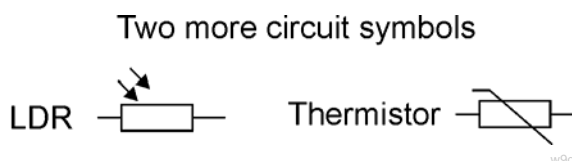

- A ntc thermistor has a resistance which falls as the temperature rises.
- A ptc thermistor has a resistance which increases as the temperature rises.
- The resistance of a LDR falls as the light intensity increases.

# Worksheet 10

## Voltage dividers

# Electricity matters

## 2

Earlier, we looked at how resistors restrict the flow of electric current. This is why a resistor, connected in series, can protect components, such as LEDs from damage by high current.

Combinations of resistors can be used with a different purpose — to carve up the voltage from a power supply into smaller portions. Not surprisingly, these combinations are called voltage dividers. The diagram shows how a power supply voltage  $V_S$  can be split into two smaller voltages  $V_1$  and  $V_2$  by a voltage divider made up of two resistors.

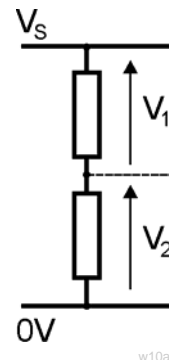

These are particularly useful when one of the resistors is a sensing component such as a LDR or a thermistor.

Voltage dividers form the basis of many sensing sub-systems. The output voltage from them can represent temperature, light-level, pressure, strain or many other physical quantities.

**Over to you:**

1. Set up the arrangement shown in the circuit diagram .
2. Make sure that the power supply voltage is set to 3V!
3. Use a multimeter to measure the voltages  $V_1$  and  $V_2$  in turn. Write your results in a table like the one shown opposite.
4. Change the power supply voltage to 6V.
5. Measure voltages  $V_1$  and  $V_2$  again and write the results in the second line of the table.
6. Do the same thing with a power supply voltage set to 9V.

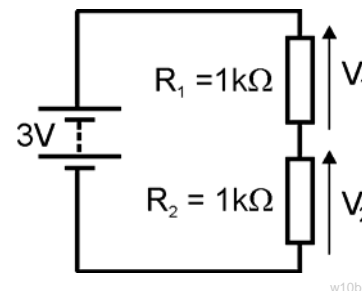

Supply Voltage $V_S$	Voltage $V_1$ across $R_1 = 1k\Omega$	Voltage $V_2$ across $R_2 = 1k\Omega$
3V		
6V		
9V		

Supply Voltage $V_S$	Voltage $V_1$ across $R_1 = 1k\Omega$	Voltage $V_2$ across $R_2 = 5k\Omega$
3V		
6V		
9V		

**Over to you:**

Next, swap the  $R_2$   $1k\Omega$  resistor for a  $5k\Omega$  resistor. Leave resistor  $R_1$  unchanged. Change the power supply voltage back to 3V. Measure voltages  $V_1$  and  $V_2$  again. Write the results in a new table. Repeat this process, first using power supply voltages of 6V and then using 9V.

# Worksheet 10

## Voltage dividers

# Electricity matters

## 2

### So what?

There is a straightforward way to view these results:

- The voltage from the power supply is shared between the resistors, so that  $V_1 + V_2 = V_S$ .
- The bigger the resistor, the bigger its share of the voltage.

When  $R_1 = R_2 (=1k\Omega)$ ,  $V_1 = V_2 = \frac{1}{2}V_S$ .

When  $R_2 = 5 \times R_1$ ,  $V_2 = 5 \times V_1$ .

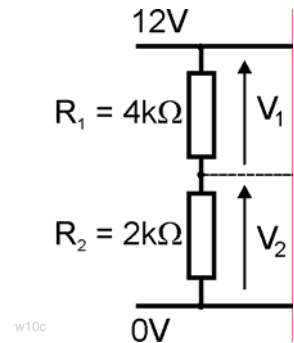

For example, look at the circuit opposite:

We know two things:  $V_1 + V_2 = V_S = 12V$   
and:  $R_1 = 2 \times R_2$ , so  $V_1 = 2 \times V_2$

In other words, one voltage is twice as big as the other, and they add up to 12V. A little thought should convince you that  $V_1 = 8V$  and  $V_2 = 4V$ .

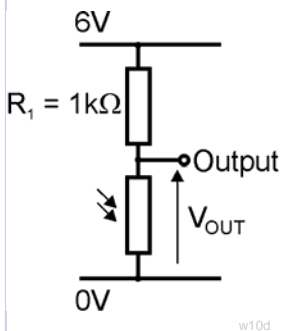

### The Light-Sensing Unit:

Set up the circuit shown here. It is a voltage divider with a LDR as one of the resistors.

Make sure that the power supply voltage is 6V.

Connect a voltmeter to read the output voltage  $V_{OUT}$ .

Notice the effect of covering up the LDR, or shining a torch at it.

### The Temperature-Sensing Unit:

Modify your circuit by changing the LDR for a thermistor.

(You may find it better to use a  $5k\Omega$  resistor for  $R_1$ .)

Connect a voltmeter to read the output voltage  $V_{OUT}$ .

Notice the effect of warming up the thermistor between your fingers.

What is the effect of turning the voltage divider upside-down so that  $R_1$  is at the bottom and the thermistor at the top?

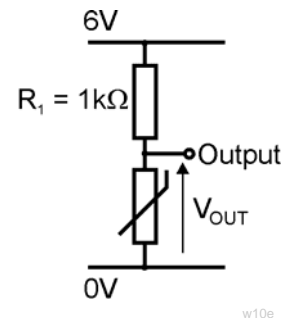

### For your records:

- Copy the following diagram of a voltage divider:
- The voltage divider rules:
  - $V_1 + V_2 = V_S$
  - $R_1 / R_2 = V_1 / V_2$ ,

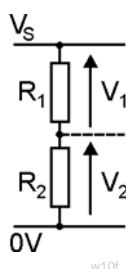

- Copy the following table and complete it by calculating the missing values:

Supply Voltage $V_S$	Resistor $R_1$ in $k\Omega$	Resistor $R_2$ in $k\Omega$	Voltage $V_1$ in V	Voltage $V_2$ in V
6V	12	12		
6V	1	2		
12V	3	1		
9V	2		3	

# Worksheet 11

## Voltage dividers

## Electricity matters

### 2

In earlier worksheets, we looked at resistors and how they could be used to limit electric current, and at their use in voltage dividers. Now we turn to the use of variable resistors.

These are very common in a wide range of electronic appliances. They act as volume controls in radios and hi-fi, lighting dimmers, mixers in karaoke and recording desks, and adjustable thermostats in heating systems. They are widely used in sensors, such as light-sensing units.

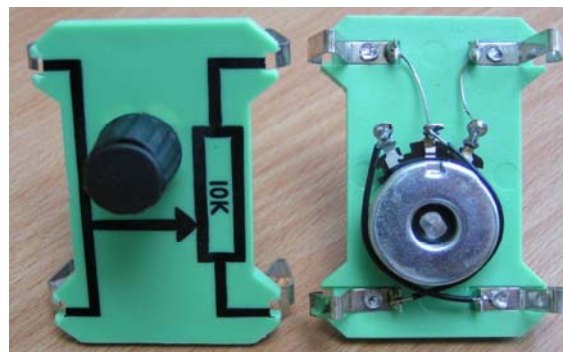

Variable resistors are also called potentiometers (often shortened to 'pot'), or rheostats (when they are designed to carry high current.)

The diagram shows the inner workings of a typical 'pot'.

There are three solder tag terminals, **A**, **B** and **C**.

**A** and **B** are connected to the ends of a carbon track, shaped, in the diagram as a letter 'C'. This track has a fixed resistance - 10 kilohm for the one shown in the picture above. **C** is connected to a 'wiper', that slides around the carbon track, when the knob on the component is turned.

In effect, there are two resistors,  $R_A$  and  $R_B$ , built into the device,  $R_A$  being the resistance of the track between **A** and **C**, and  $R_B$  the resistance of the track between **B** and **C**. The symbols for these resistors is superimposed onto the first diagram.

The second diagram is more accurate as it shows that the two resistors  $R_A$  and  $R_B$  are in fact variable - hence the arrows through the symbols.

When the knob is turned in the direction shown by the arrow, the length of track between **B** and **C** increases, so that  $R_B$  increases, whereas the track between **A** and **C** shortens, so that  $R_A$  decreases.

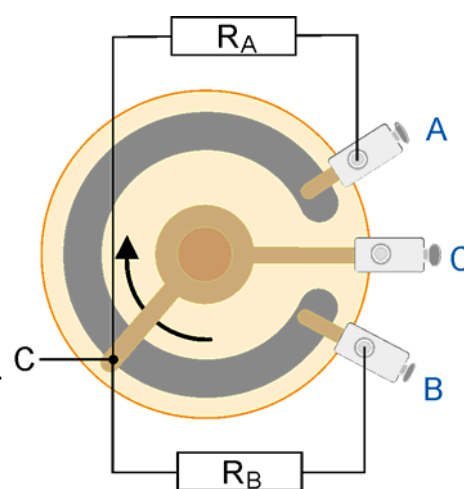

w11b2

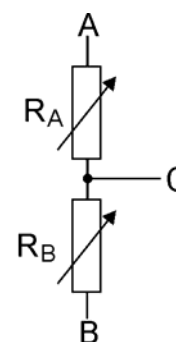

w11c2

# Worksheet 11

## Voltage dividers

## Electricity matters

### 2

#### Over to you:

1. Set up the arrangement shown in the circuit diagram. Make sure that the power supply voltage is set to 6V!
2. Here, the Locktronics component is set up as a variable resistor. You can tell this because the circuit uses only two legs of the component. (Resistors have only two legs!) It is quite difficult to build this circuit. The picture below shows how to include the variable resistor.

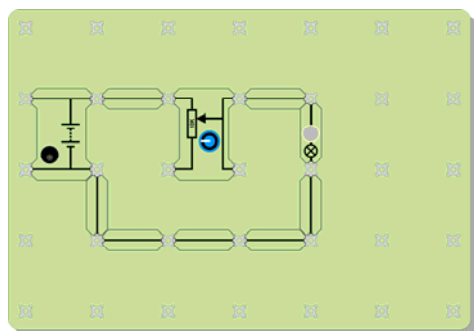
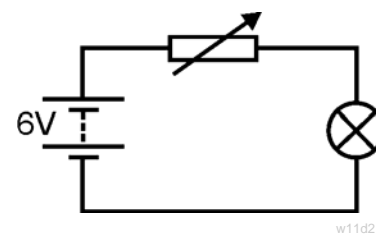

#### Over to you:

1. Turn the knob on the variable resistor and notice the effect on the brightness of the bulb.
3. Next connect the component as a voltage divider. You used this arrangement earlier when studying diodes and LEDs. The circuit diagram is shown below.

4. Notice that a new symbol is used for the component! Test the circuit as before - turn the knob and see what happens to the brightness of the bulb.

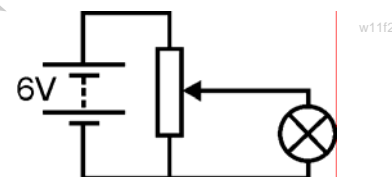

#### So what?

There is an important difference in the way the component is used in the two exercises. As a variable resistor, it controls the current flowing through the bulb. They are in series, so whatever current flows through the bulb also flows through the variable resistor. This current may be very small when the knob is turned to give maximum resistance, but it is never zero. As a voltage divider, it controls the voltage applied to the bulb. The current through the bulb will now be zero when the knob is turned to one extreme. However, there is always a current flowing through the 'pot' itself. It is important to make this current large, compared to the current flowing through the bulb. **A challenge** - Connect a voltmeter to read the voltage across the bulb. Unscrew the bulb. Turn the knob until the voltmeter reads 3V. Now screw the bulb in, and watch what happens to the voltmeter reading. Explain what is going on to your partner and then to your teacher.

#### For your records:

- Copy the diagram that shows the inner workings of the 'pot'. Write instructions to connect this as a variable resistor to control the brightness of a bulb.
- Explain what is going on when you turn the knob.

Copy the two circuit diagrams to show how to control the brightness of the bulb

- using the variable resistor method, and using the voltage divider method.

# Worksheet 12

## Electrical power

## Electricity matters

### 2

'**Save energy**' - a familiar message today! It would help to know what energy is! Is it the same thing as power? Is it voltage? Or wattage?

Our aim is to spell out some connections between these quantities.

We said earlier that electricity stems from how electrons behave, but unfortunately, they are too small to see, or measure. Instead, we introduce the 'coulomb', and talk about that.



w11000008151605Small

**Electric current** is a measure of how many electrons are passing per second.

**Voltage** is a measure of the energy the electrons gain or lose as they pass through an electrical component.

### First - a confession:

Some of the greatest physicists of modern times, don't know what energy is, don't expect glib answers from us!

Instead, here's an equally difficult question - what is 'money'? To some, it is silver discs with writing stamped on it. To others it is pieces of paper with words printed on it, bars of gold, or diamonds, or barrels of oil, or how many goats your family has. What it is never worries us - we just spend it! With energy, it is the same. We can't really say what it is, but we know how to use (and abuse) it!

### Next - a convenient invention:

Whatever energy is, electrons (whatever they are,) gain it when they pass through a battery or a power supply, and lose it when they flow through resistors, or coils of wire or the like. However, we can't track individual electrons, so we invent a name for a huge herd of them. We call it a **coulomb**.

To estimate how many people turn up at a football match, you could count the number of buses bringing them, knowing that a bus carries a certain number of people.

It is rather like that with electricity. We talk about coulombs of electrical charge, knowing that each coulomb is a huge number of electrons (6,250,000,000,000,000 in fact - quite a bus-full!)



# Worksheet 12

## Electrical power

## Electricity matters

### 2

#### So what?

- With the bulbs in series, each electron passes through both and shares its energy between them.
- With the bulbs in parallel, an electron passes through only one, and gives it all its energy.

Which battery will 'go flat' first? Explain your answer to your teacher.

#### For your records:

- Copy the three facts given above (but not the comments in brackets after each.)
- When a component has a voltage  $V$  across it, and a current  $I$  flowing through it, it is converting energy from one form to another at a rate given by the power formula

$$P = I \times V.$$

# Quiz

## Electricity matters 2

### Round 1

- (a) Write down the names of **five** materials which conduct electricity. (b) What is the name of the substance in a switch that stops the electric current flowing when the switch is turned off?

Here are six circuit symbols. Which one:

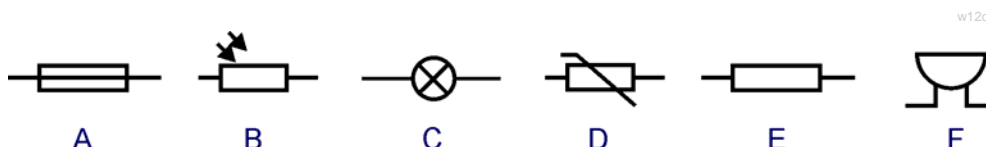

- (c) is the buzzer (sounder) ?  
 (d) Is used as an indicator?  
 (e) has a resistance that gets less when it gets hot?  
 (f) is the LDR?

### Round 2

Use either the word 'series' or the word 'parallel' to fill in the gaps:

- (a) Voltmeters are connected in ..... with the component they are measuring.  
 (b) Ammeters are connected in ..... to measure the current through a component.  
 (c) In a ..... circuit, the same current flows everywhere.  
 (d) Components connected in ..... have the same voltage across them.  
 (e) Resistors connected in ..... reduce the current flowing more than the same resistors connected in .....

### Round 3

Black	Brown	Red	Orange	Yellow	Green	Blue	Purple	Grey	White
0	1	2	3	4	5	6	7	8	9

Resistor	Band 1	Band 2	Band 3	Band 4
A	yellow	purple	orange	silver
B	yellow	purple	black	gold
C	brown	red	brown	silver
D	red	red	brown	silver
E	green	blue	red	silver

The first table shows the resistor colour code.

The second one gives the colours of the bands of five resistors A to E.

Which one of these resistors :

- (a) has the biggest resistance?  
 (b) has a resistance of  $47\Omega$ ?  
 (c) when connected in series with a  $100\Omega$  resistor, has a combined resistance of  $220\Omega$ ?  
 (d) is made to the greatest accuracy?

# Quiz

## Electricity matters 2

### Round 4

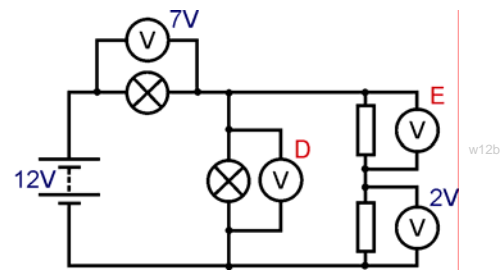
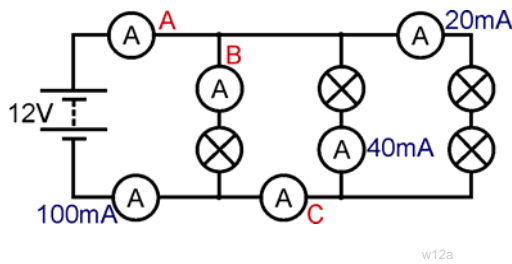

Write down the readings on ammeters **A**, **B** and **C**, and voltmeters **D** and **E**.

### Round 5

A resistor **R** has a current **I** flowing through it and a voltage **V** across it. Use Ohm's law formulae to calculate the missing values in the table below.

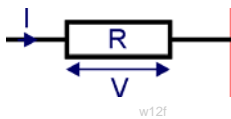

	Current I	Voltage V	Resistance R
(a)	0.1A	2V	?
(b)	0.3A	?	20Ω
(c)	?	12V	100Ω
(d)	5mA	?	2.2kΩ

### Round 6

Look at the circuit opposite. Calculate the following quantities:

- (a) current **I**;
- (b) voltage **V<sub>1</sub>**;
- (c) voltage **V<sub>2</sub>**;
- (d) voltage **V<sub>3</sub>**.

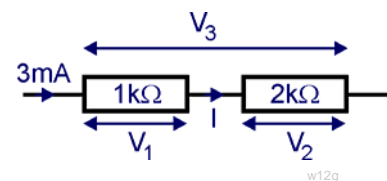

The next table gives you information about some voltage dividers like the one shown. Complete the table by calculating the missing information.

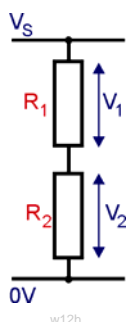

	R <sub>1</sub>	R <sub>2</sub>	V <sub>1</sub>	V <sub>2</sub>	V <sub>s</sub>
(e)	5kΩ	5kΩ			12V
(f)	2kΩ		2V	4V	
(g)		10kΩ	3V		9V
(h)	20kΩ	5kΩ		1V	

# Quiz

## Electricity matters 2

### Round 7

- (a) A current of 0.2A flows through a resistor for 10 seconds.  
How many coulombs of charge have passed through the resistor?
- (b) A resistor has a current of 20mA flowing through it. A voltmeter connected across it has a reading of 5V. What power is dissipated in the resistor?
- (c) An electric kettle has a power rating of 3000W when connected to a 250V supply.  
(i) What current flows through the kettle element when it is switched on?  
(ii) Which of the following fuses should be used to protect the kettle?  
3A      5A      13A      50A

# Teacher's notes

## Electricity matters 2

### About this course

#### Introduction

The course is essentially a practical one. Locktronics equipment makes it simple and quick to construct and investigate electrical circuits. The end result can look exactly like the circuit diagram, thanks to the symbols printed on each component carrier.

#### Aim

The course aims to introduce pupils to the basic concepts and relationships in electricity.

#### Prior Knowledge

It is recommended that pupils have followed the 'Electricity Matters 1' course, or have equivalent knowledge and experience of building simple circuits.

#### Learning Objectives

On successful completion of this course the pupil will have learned:

- the difference between the electrical properties of conductors and insulators;
- how to test whether a material conducts electricity readily or not;
- the meaning of a range of electrical symbols;
- to construct a simple electrical circuit from a circuit diagram;
- to recognise a series connection and recall its properties;
- to recognise a parallel connection and recall its properties;
- the effect of resistance on the size of the current flowing;
- that resistance is measured in ohms;
- the function of a switch in an electrical circuit;
- how to place a switch to control only part of a circuit;
- how to use a multimeter to measure current;
- how to use a multimeter to measure voltage;
- how to use a multimeter to measure resistance;
- to recall and use the formulae derived from Ohm's Law;
- to recall and use the resistor colour code;
- to connect a diode and a LED in forward biased mode;
- to compare and distinguish between the properties of diodes and LEDs in both forward and reverse bias;
- to describe the change in resistance that takes place when a LDR is exposed to light;
- to describe the change in resistance that takes place when a thermistor is warmed;
- to calculate the voltage across the components of a voltage divider;
- to set up a variable resistor to control the brightness of a bulb;

# Teacher's notes

## Electricity matters 2

### What the student will need:

This pack is designed to work with the Locktronics Electricity, magnetism and Materials kit. The contents of this kit can be seen in the table on the right. Not all these components are used in this pack, and some will be used in the 'Electricity matters 1' pack.

Students will also need either two multimeters, one capable of measuring currents in the range 0 to 100mA, the other measuring voltages in the range 0 to 15V, or an ammeter capable of measuring currents in the range 0 to 100mA, and a voltmeter capable of measuring voltages in the range 0 to 15V.

If you are missing any components then please contact Matrix or your local dealer.

### Power source:

Although there are two ways to power these circuits, either with C type batteries on a baseboard containing three battery holders, or using a mains-powered power supply, at this level the latter is more suitable, and the worksheets are written using that approach. The larger baseboard is appropriate for use with this power supply, which can be adjusted to output voltages of either 3V, 4.5V, 6V, 7.5V, 9V or 13.5V, with currents typically up to 1A. The voltage is changed by turning the selector dial just above the earth pin until the arrow points to the required voltage. The teacher may decide to make any adjustment necessary to the power supply voltage, or may allow pupils to make those changes.

Each exercise includes a recommended voltage for that particular circuit.



Qty	Code	Description
1	HP4039	Lid for plastic trays
1	HP5328	International power supply with adaptors
1	HP5540	Deep tray
1	HP7750	Locktronics daughter tray foam insert
1	HP9564	62mm daughter tray
2	LK0052S	PENCIL LEAD
1	LK0079	HARDBOARD DISCS
1	LK0123	Magnet
1	LK0124	Compass
1	LK114-1	WIRE NAIL
1	LK119-346	WIRE WOOL FINE (Gram)
2	LK1351-001	COPPER FOIL (small strip)
3	LK2347	MES bulb, 6V, 0.04A
1	LK4102	Motor - open frame, 6V, large carrier
1	LK5100	Locktronics current probe
1	LK5144	Photocell LDR
2	LK5202	Resistor - 1K, 1/4W, 5%
1	LK5214	Resistor - variable, 10K
1	LK5203	10K resistor
1	LK5245	Diode (1N4004)
9	LK5250	Connecting Link
3	LK5291	Lampholder carrier
1	LK5297	Lead - black - 320mm, 4mm to croc clip
1	LK5298	Lead - black - 320mm, 4mm to croc clip
1	LK5299	Eureka wire bobbin
1	LK5598	Lead - red 100mm, 4mm to 4mm stackable
1	LK5599	Lead - black 100mm, 4mm to 4mm stackable
1	LK6207	Switch Press (morse key-type strip, push to make)
1	LK6209	Switch on/off (stay put, sideways swivel strip)
1	LK6423	Buzzer (6V 15mA)
1	LK6492	Curriculum pack CD ROM
1	LK6850	Thermistor and moisture sensor PCB
1	LK6917	Locktronics blister pack lid
1	LK6921	Locktronics blister pack clear tray & insert
1	LK7936	Fuse carrier
1	LK8275	Power supply carrier with battery symbol
1	LK8900	Baseboard 7 x 5 pillars
50	LK-T060	WIRE GREEN PVC (cm)

# Teacher's notes

## Electricity matters 2

### Using this course:

It is expected that the worksheets are printed / photocopied, preferably in colour, for the pupils' use. Pupils do **not** need their own permanent copy.

Each worksheet has:

- an introduction to the topic under investigation;
- step-by-step instructions for the investigation that follows;
- a section headed 'So What', which aims to collate and summarise the results, and offer some extension work. It aims to encourage development of ideas, through collaboration with partners and with the teacher.
- a section headed 'For Your Records', which can be copied and completed in pupils' exercise books. Alternatively, the 'Student Handout' can be photocopied and distributed to the pupils. This is a compilation of the 'For Your Records' sections.

The idea is to save time by presenting the pupils with the body of the summaries, which they complete as they carry out the investigations on the worksheets.

This format encourages self-study, with pupils working at a rate that suits their ability. It is for the teacher to monitor that pupils' understanding is keeping pace with their progress through the worksheets. One way to do this is to 'sign off' each worksheet, as a pupil completes it, and in the process have a brief chat with the pupil to assess their grasp of the ideas involved in the exercises it contains.

*"...but I'm really a biology teacher..."*

Knowing that multidisciplinary integrated science teaching teams are increasing in popularity, the Teacher Guide is written with the intention of helping those teachers for whom physics is not their principal qualification or area of experience. It includes anecdotes and analogies to help deliver the concepts, and advice about pitfalls and misconceptions that may be present.

### Time:

It will take pupils between six and seven hours to complete the worksheets. It is expected that a similar length of time will be needed to support the learning that takes place as a result.

## Teacher's notes

Electricity matters  
2

Work-sheet	Notes for the Teacher	Timing
	<p>The first four worksheets are designed to remind pupils of the work done earlier, in the 'Electricity Matters 1' course (or equivalent.) Later worksheets then introduce further ideas and relationships between the basic parameters in electricity.</p>	
1	<p>Introductory brainstorming/discussion/trigger questions could cover:</p> <ul style="list-style-type: none"> <li>What is electricity?</li> <li>Where does electricity come from?</li> <li>What do we use it for?</li> </ul> <p>In the first worksheet, we examine the use of circuit symbols as an efficient way of describing the structure of a circuit. As an introduction, pupils could be shown, or could find for themselves, a number of common non-electrical symbols to demonstrate that these pictorial messages are quick and easy to understand. They should be encouraged to learn the basic symbols, and research a range of others.</p> <p>The pupils compare a pictorial representation of a circuit, with a circuit diagram, to see whether both represent the same circuit. It is worth pointing out that the circuit diagram is much easier to draw!</p> <p>They are then asked to build, and comment on four circuits, to give practice in interpreting circuit diagrams. Then, they build a circuit without the aid of a picture, using only the circuit diagram.</p> <p>Finally, the worksheet gives them a table of common symbols to learn.</p>	30 - 45 minutes
2	<p>After distinguishing between them, the first exercise looks at two classes of substance—conductors and insulators. First of all, though, the pupils set up a simple circuit to light a bulb to ensure that the components all work properly! They then test a range of materials to see which category they belong to, by clamping each sample under the screw terminals of the sampler. If the bulb lights, the sample is deemed to be a conductor!</p> <p>The exercise points pupils towards the fact that metals conduct electricity well, whereas most other classes of substance do not. Most importantly, air is an insulator (though the teacher might raise the issue of lightning!) They are asked to devise a means for testing water. In reality, the result depends on the purity of the water used. This could form part of a class discussion on appropriate test methods.</p> <p>It may be appropriate to pick out the result that some substances conduct better than others. The present day electronics industry is built around materials called semiconductors, that are neither conductors nor insulators under normal conditions. Implicitly, the exercise also shows that an electric current flows only when there is a complete circuit.</p> <p>The use of a switch is investigated next. The connection is that the switch connects either a conducting path of brass, (the 'on' position) or an insulating slab of air (the 'off' position) into the circuit.</p> <p>The pupil is encouraged to try different configurations to control two lamps. There is a large number of switch types available. Two broad categories are introduced, the 'push' switch (or momentary acting switch,) and the toggle (or latching) switch. Pupils could be set the task of researching other types of switch, and applications in which they could be used.</p>	30 - 45 minutes

## Teacher's notes

Electricity matters  
2

Work-sheet	Notes for the Teacher	Timing
5	<p>At this point we move on from using the brightness of a bulb as a measure of current to the use of an ammeter. Teachers may prefer to use discrete meters rather than multimeters for this and subsequent worksheets.</p> <p>Multimeters are in widespread use because of their low cost and versatility. Although they differ in terms of the functions they offer and the precise details of their structure, the broad principles are the same. Here we look at their use to measure current (ammeter function) and later to measure voltage (voltmeter function.)</p> <p>We address the distinction between DC ranges and AC ranges, without going into detail about DC and AC.</p> <p><b>Beware!</b> It is common to find that the ammeter settings are protected by an internal fuse. This is frequently 'blown' because pupils switch on the multimeter, connected as a voltmeter, with the dial turned to a current range. Teachers should check all fuses prior to this exercise, and be prepared with a supply of replacement fuses!</p> <p>The aim of the exercises is to spot the pattern for current flow in a circuit, that the total current leaving any junction in the circuit is equal to the total current entering the junction. (Compare this with traffic at a road junction, where crashes and parking can lead to a different result.)</p> <p>The worksheet ends with a close exercise and questions requiring pupils to apply the current rule discovered in the exercise.</p>	25 - 40 minutes
6	<p>This worksheet mirrors the structure of the last one, but looks at measuring voltage.</p> <p>The point is made in the introduction, that it is relatively easy to visualise an electric current - millions of electrons slowly squeezing their way along a wire, like crowds of people in a shopping mall, but more difficult to visualise voltage. It is a topic we return to in worksheet 11.</p> <p>For the present, the exercise concentrates on measuring voltage, rather than defining it. Pupils use a multimeter for this, by connecting it in parallel with the section of the circuit under investigation.</p> <p>The circuit diagram at the top of the second page of the worksheet shows three voltmeters. The pupil does not need three multimeters, but can move one from one voltmeter position to the next to take the three readings.</p> <p>Again, pupils are asked to look for a pattern in their results. This is that the total of the voltmeter readings in any loop of the circuit is equal to the power supply, or battery, voltage.</p> <p>Again, worksheet ends with a close exercise and questions requiring pupils to apply the voltage rule from the exercise.</p>	25 - 40 minutes

## Teacher's notes

Electricity matters  
2

Work-sheet	Notes for the Teacher	Timing
7	<p>This worksheet focuses on the popular examination topic of Ohm's Law. It introduces the use of a potentiometer as a variable voltage supply. Pupils might need help in setting up the circuit, though a picture is provided to assist with this.</p> <p>The instructions refer to an ammeter and a voltmeter, but while it is possible to use a single multimeter to do both jobs, it makes it much easier if the pupil has two multimeters. If using only one, once the current is measured, a connecting link must replace the ammeter, while the multimeter is acting as a voltmeter.</p> <p>The voltage adjustment is delicate, and pupils should be encouraged to have patience when setting it to the values given in the table.</p> <p>Ohm's Law actually applies only when a very specific, and unrealistic, set of circumstances apply. In particular, the temperature of the conductor (resistor in our case,) must not change. As the current through it increases, the resistor gets hot! We attempt to limit this by specifying a maximum of 1.0V across the resistor. The pupils plot a graph of their results, and can use it to obtain a value for the resistance of the resistor.</p> <p>The next section introduces the resistor colour code. Teachers may want to spend time giving further examples of its use. There are questions on this at the end of the worksheet, and in the Quiz at the end of the course.</p> <p>A guide on using a multimeter to measure resistance follows,. The most important aspect of this is that this cannot be done 'in-circuit'. The component must be removed from the circuit for the measurement.</p> <p>The worksheet ends with questions on using the Ohm's Law formulae, and on applying the colour code.</p>	25 - 40 minutes
8	<p>In very limited situations, a small number of components obey Ohm's Law. Usually, it does not apply. This needs to be made clear, as otherwise the prominence given to the law can give the misleading impression that it commonly applies.</p> <p>Here the pupils study two common components that do not obey Ohm's Law., the diode and LED. A similar arrangement to that in worksheet 7 is used to control the voltage and current through the components. This time, though, it is more logical to increase the current in steps.</p> <p>The terms 'forward-biased' and 'reverse-biased' are introduced, but may need reinforcement by the teacher. The pupils plot graphs to show the results for the diode and the LED, and they are given the generalised, and approximate, result that the forward voltage drop for the diode is 0.7V and for the LED 2V.</p> <p>The worksheet ends with a summary of the findings.</p>	30 - 45 minutes

## Teacher's notes

## Electricity matters

## 2

Work-sheet	Notes for the Teacher	Timing
9	<p>This worksheet introduces two components widely used in sensing circuits - the subject of the following worksheet. For the moment, pupils look at the effect of changing temperature on the resistance of a thermistor, and then design an experiment to investigate how light intensity affects the resistance of a LDR.</p> <p><b>Be aware that the first investigation uses hot water, which might pose a hazard!</b> The set up requires either a liquid-in-glass thermometer, <b>another potential hazard</b>, or a temperature probe and associated digital meter.</p> <p>They design the experiment to study the effect of light intensity on the resistance of the LDR. They may need to be reminded of the need to make it a fair test, in particular, to keep all other possible influences constant throughout. The teacher may wish to provide them with a light-meter to measure the intensity. The units of light intensity are complex, and beyond the present course of study. The pupils should use whatever units the meter is calibrated in!</p>	25 - 40 minutes
10	<p>Resistors return to the fore again but this time as voltage divider circuits, rather than as current-controlling devices.</p> <p>The investigation sets up two voltage dividers, made from different pairs of resistors. The results are then explained in terms of two simple rules - the sum of the voltages across the resistors equals the power supply voltage, and the bigger the resistor, the bigger its share of the supply voltage.</p> <p>The voltage divider forms the basis for a number of sensing circuits. The use of a thermistor and a LDR in voltage dividers to produce temperature-sensing and light-sensing units respectively is investigated next.</p> <p>Note: - the value of the resistor used within the voltage divider may need changing to accommodate different LDRs or thermistors.</p> <p>Ideally, a variable resistor is used in the voltage divider instead of the fixed resistor, so that the output voltage can be adjusted to meet system requirements. At this stage, this is probably an unnecessary complication, but it could be set as a challenge for an able pupil.</p> <p>The worksheet ends with questions requiring pupils to determine the voltages across the components of a number of voltage dividers.</p>	30 - 45 minutes
11	<p>Voltage divider circuits, especially sensing circuits, often contain variable resistors. Although the principle of a variable resistor may be straightforward, the practice of using them in a circuit causes many problems.</p> <p>The component itself is usually called a potentiometer, or 'pot'. It has three legs! It can be set up in two ways, as a voltage divider (also often called a 'pot', to add to the confusion,) or as a variable resistor.</p> <p>Resistors have two legs. Variable resistors have two legs - so which two, of the three, to use? The answer is - use the middle leg, (the wiper,) and either of the end legs. A picture is provided to help pupils construct this circuit.</p> <p>As a voltage divider, all three legs are used. The earlier worksheets 7 and 8 used a pot as a voltage divider to produce a variable voltage power supply. It may be worth referring pupils back to those worksheets, to see how that was done.</p>	30 - 45 minutes

# Teacher's notes

## Electricity matters 2

Work-sheet	Notes for the Teacher	Timing
<b>12</b>	<p>Pupils should already have met the concept of energy, and energy transfer. This worksheet aims to connect and clarify a number of concepts relating to electrical power, specifically energy, power, current and voltage.</p> <p>The discussion leads to three 'facts' (definitions), and uses them to obtain the relationship <math>P = I \times V</math>.</p> <p>The investigation into three circuits is designed to give pupils experience of electrical calculations in the context of actual circuits.</p>	<b>25 - 40 minutes</b>
<b>Quiz</b>	<p>This is offered as one means of assessing a pupil's grasp of the topics covered in the worksheets. It can be run as a conventional test, answered by each pupil individually, or can be organised as a 'pub' quiz for the whole class, where the teacher splits the pupils into teams. The questions could be printed out for the teams, or could be projected onto a screen with a data projector.</p>	<b>30 - 45 minutes</b>

# Student handout

## Electricity matters 2

### Worksheet 1 - Add the correct symbols:

w14a

Battery - supplies electrical energy	Toggle switch - allows a circuit to work	Lamp - turns electricity into light	Fuse - a safety device	Resistor - controls the size of the current	Sounder - turns electricity into sound

### Worksheet 2

- Most of the conductors belong to the class of substances called .....
- I think that the hard shiny object that felt cold would ..... electricity, because it is probably made of a .....
- Pure water is an ..... However, if there are any impurities in it, such as salt, or chlorine, then the water is a .....
- Air is an ..... which explains why we do not get an electric shock when we stand near a mains electricity socket.
- A switch starts and stops the flow of .....
- When the switch is open, the ..... gap stops the flow of electricity.
- When the switch is ....., the air gap disappears, and electricity flows around the circuit.
- A toggle switch stays on or stays off all the time. A push switch is on only as long as you press it.
- A doorbell is one type of ..... switch.
- A light switch is one type of ..... switch.

### Worksheet 3

- A resistor limits the flow of electricity.
- The bigger the resistance, the smaller the electric current.
- Resistance is measured in ohms. Usually, we use the  $\Omega$  sign to mean 'ohms'.

### Worksheet 4

- A series circuit offers only one route for the electric current.
- If a break appears anywhere in the circuit, then the electric current stops everywhere.
- If one bulb fails in the circuit, then all the bulbs go out.
- The electric current is the same size throughout the circuit.
- A parallel circuit offers several routes so that different currents can flow in different parts of the circuit.

1. Bulb B is in series with bulb .....
2. Bulb C is in ..... with bulb E and bulb F.
3. Bulbs B and D are in ..... with bulbs C, E and F.
4. The biggest current will flow through bulb .....

w14b

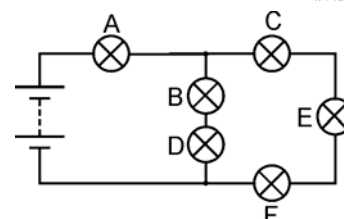

# Student handout

## Electricity matters 2

### Worksheet 5

- In a series circuit, the ..... current flows in all parts.
- In a parallel circuit, the currents in all the parallel branches add up to the current leaving the .....
- Write the readings on ammeters A to H alongside each ammeter.

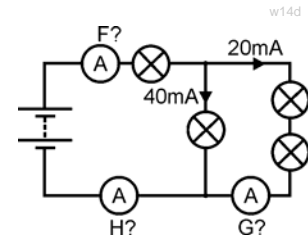
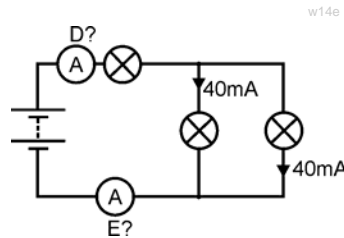
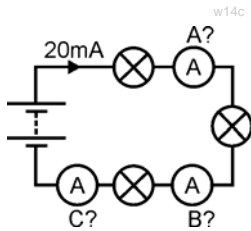

### Worksheet 6

- In a series circuit, the voltages across the components add up to the voltage across the .....
- In a parallel circuit, the components all have the ..... voltage across them.
- Write the voltages across bulbs A to E alongside each voltmeter.

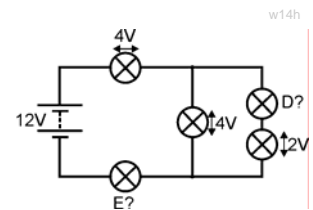
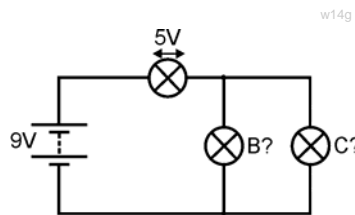
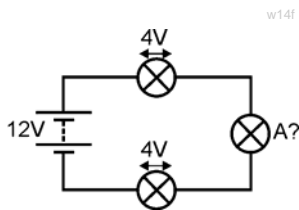

### Worksheet 7

- Ohm's law gives us the following equations:  $V = I \times R$   $R = V / I$   $I = V / R$  where  $R$  = resistance in ohms,  $I$  = current in amps and  $V$  = voltage. (This also works for resistance in kilohms and current in milliamps, because kilo and milli cancel out.)

- Calculate the missing quantities:

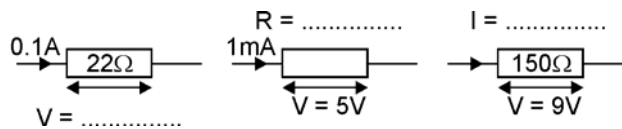

- The resistor colour code is used to show the resistance of a resistor.

Black	Brown	Red	Orange	Yellow	Green	Blue	Purple	Grey	White
0	1	2	3	4	5	6	7	8	9

- Use it to complete the table:

Band 1	Band 2	Band 3	Resistance
Brown	Black	Yellow	
Green	Blue	Red	
Grey	Red	Black	

# Student handout

## Electricity matters 2

### Worksheet 8

- The diode is a 'one-way valve'. It allows current to flow through it in only one direction.
- When it conducts, there is a voltage drop of about 0.7V across it.
- It conducts when it is forward-biased, and does not when reverse-biased.
- Add the correct labels to the diagram:

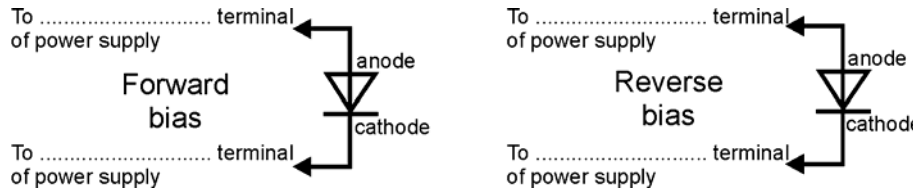

- Draw the symbol for a LED. LED
- The light-emitting diode (LED) behaves in the same way.
- It lights up when forward biased, and the current reaches about 10mA.
- It then has a voltage drop of about 2V across it.
- It needs to be protected from high currents by connecting a resistor in series.

### Worksheet 9

- Draw the symbols for a thermistor and a LDR. Thermistor
- A ntc thermistor has a resistance which falls as the temperature rises.
- A ptc thermistor has a resistance which increases as the temperature rises.
- The resistance of a LDR falls as the light intensity increases.

LDR

### Worksheet 10

- The voltage divider rules:
  - $V_1 + V_2 = V_S$
  - $R_1 / R_2 = V_1 / V_2$ ,

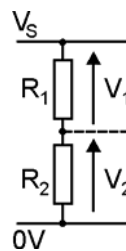

- Complete the following table by calculating the missing values:

Supply Voltage $V_S$	Resistor $R_1$ in $k\Omega$	Resistor $R_2$ in $k\Omega$	Voltage $V_1$ in V	Voltage $V_2$ in V
6V	12	12		
6V	1	2		
12V	3	1		
9V	2		3	

# Student handout

## Electricity matters 2

### Worksheet 11

The diagram shows the inner workings of a 'pot'.

- Write instructions to connect this as a variable resistor to control the brightness of a bulb.
- Explain what is going on when you turn the knob.

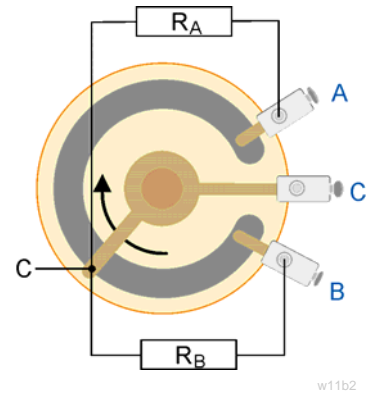

.....

.....

.....

.....

.....

.....

.....

.....

Circuit 1 - using a variable resistor to control the brightness of a bulb:

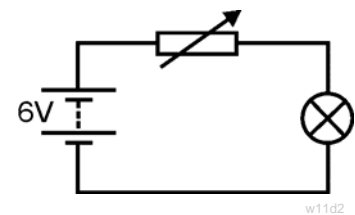

Circuit 2 - using a voltage divider to control the brightness of a bulb:

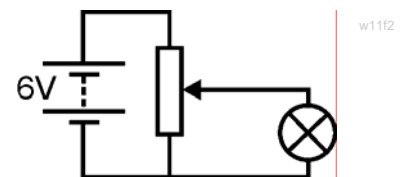

### Worksheet 12

- First fact: Number of coulombs  $Q = \text{Current } I \times \text{time } t$
- Second fact: One volt means one joule of energy given to or lost by a coulomb of charge.
- Third fact: Power is the rate at which energy is converted.
- When a component has a voltage  $V$  across it, and a current  $I$  flowing through it, it is converting energy from one form to another at a rate given by the power formula

$$P = I \times V.$$