

# locktronics

Simplifying Electricity

**Sensors and control in automotive applications**



LK8849

**MATRIX**  
[www.matrixmultimedia.com](http://www.matrixmultimedia.com)

Copyright © 2009 Matrix Multimedia Limited

# Contents

## Sense and control in automotive systems

Worksheet 1 - Simple digital sensors	3
Worksheet 2 - Lamps and simple actuators	6
Worksheet 3 - Using transistors	8
Worksheet 4 - Relays	10
Worksheet 5 - Analogue inputs	12
Worksheet 6 - Fault detection with ECUs	14
Worksheet 7 - Open loop vs closed loop	16
Worksheet 8 - Controlling DC motors	18
Worksheet 9 - Controlling stepper motors	20
Instructor guide	22
Scheme of work	25
Using a multimeter	30

# Worksheet 1

## Simple digital sensors

# Sense and control in automotive systems



Indicator stalk houses several types of switch



Brake switch component

There are many sensors in a modern car. Some are controlled by the driver (like a light switch) and some by factors in the car itself - like the fuel sensor.

Each sensor provides an input signal - often directly into an Electronic Control Unit.

The sensors in a car can be divided into two types ; **analogue** and **digital**

**Digital** sensors have a two state output, usually either 'on' or 'off'. The car power supply determines the voltages corresponding to these two states - often 12V (on) and 0V (off).

### Over to you:

1. Build the circuit shown opposite.
2. Set the power supply to 13.5V, plug into the Locktronics carrier, and switch on.
3. Press the switch to make the bulb light .

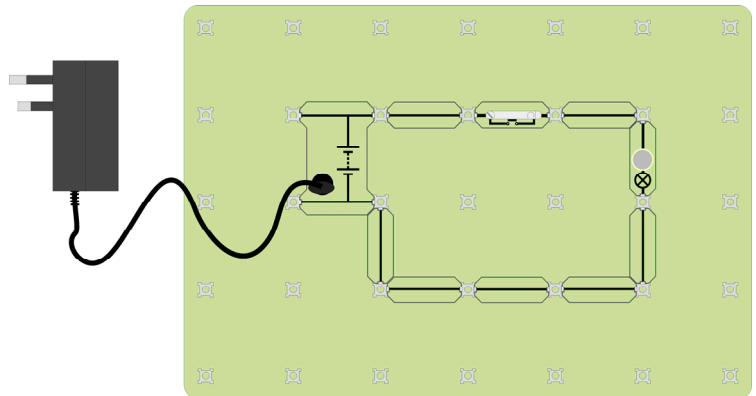

### Over to you:

4. Connect a multimeter to read the voltage across the bulb. (A Multimeter Help Sheet is available if you are unsure how to do this.)
5. Select the 20V DC range, and press the red ON/OFF switch when you want to take a reading.
6. Read the voltage across the bulb when the switch is pressed, and when not pressed.
7. Complete the table with your results:

Switch	Voltage across bulb
Pressed	
Not pressed	



# Worksheet 1

## Simple digital sensors

# Sense and control in automotive systems

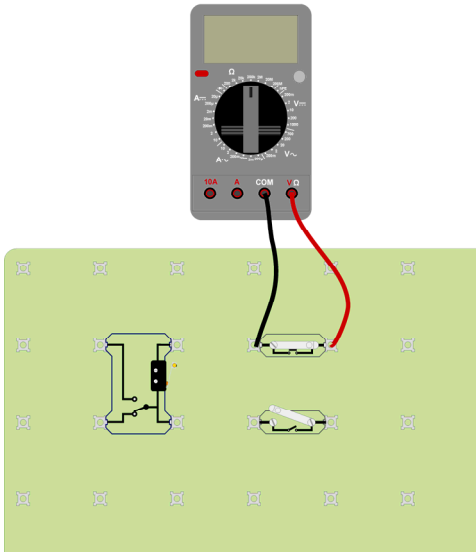

### Over to you:

1. Set up the arrangement shown. You will use it to measure the resistance of the three sensors. This must be done when they are not connected in a circuit.
2. Select the 200kΩ range. Make sure that you use the correct sockets on the multimeter. For each of the three components, measure the resistance of the switch when it is open (off) and when it is closed (on).
3. Complete the table with your results.

Component	State	Resistance
Push-to-make switch	Open (Off)	
	Closed (On)	
Slide switch	Open	
	Closed	
Microswitch	Open	
	Closed	

- These simple digital sensors have a two-state output - either open (off) or closed (on).
  - When open, they have a very high resistance.
  - When closed, they have a very small resistance.
  - When open, they output a 0V signal to the rest of the circuit.
  - When closed, they output the full power supply voltage to the rest of the circuit.
- (We will see that the last two results can be swapped round by changing the circuit.)

The circuit symbols for the components can be seen clearly on the carriers. The selection below demonstrates this. Notice that there are two types of bulb in your pack, a traditional filament bulb and a LED bulb. You can use either, but when using the LED bulbs, make sure you connect them the right way round, in the circuit.

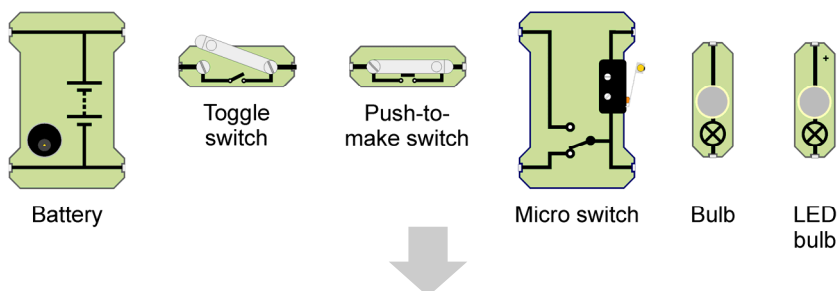

# Worksheet 1

## Simple digital sensors

# Sense and control in automotive systems

Simple digital sensors, such as switches, can output a high voltage when activated or a low voltage - depending on the circuit. Software inside an ECU can be programmed to recognise a high input voltage as the switch being either 'on' or 'off'.

### Over to you:

- Build the circuit shown opposite.  
This connects a number of simple digital sensors to a MIAC (Matrix Industrial Automotive Controller.)  
The MIAC inputs sit at 0V when there is no external input.
- Plug the power supply (13.5V) into the Locktronics carrier. It will provide power for the full system.
- If the correct program is loaded, you will see the words 'Sense and Control 1' on the MIAC screen
- Use the Up / Down arrows on the MIAC to select program 1.
- Connect a multimeter, set to the 20V DC range, to measure the signal voltage on input I1.
- Close the slide switch attached to this input.
- Complete the first row of the table below with the signal voltage from the switch before and after you closed it, and the message displayed on the MIAC screen.
- Repeat steps 5, 6 and 7 for inputs I2, I3 and I4 and the switches connected to them.
- Complete the table with your results.
- For any switch measure the input current: To do this replace the lead from the switch to the MIAC with the multimeter, set to the 2A DC range. Note your reading in the table.

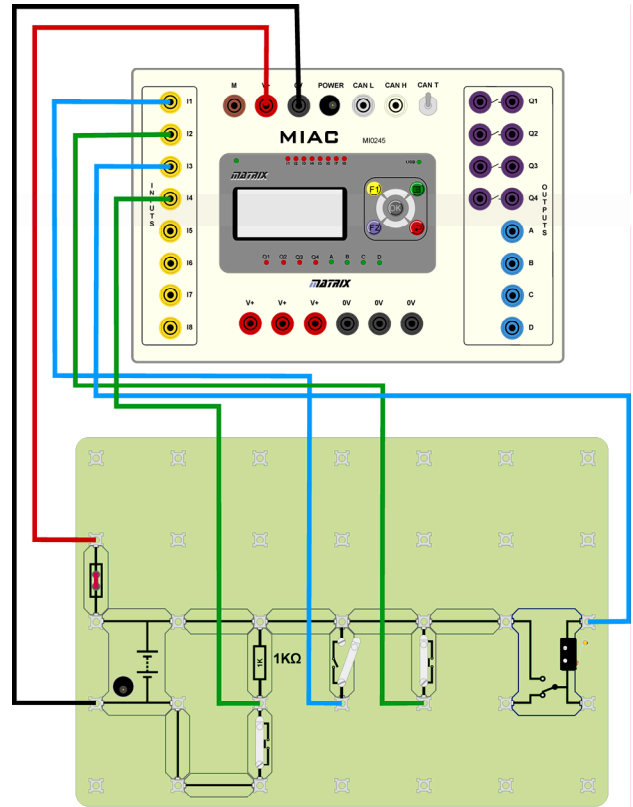

Input number	Signal voltage - switch closed	Signal voltage - switch open	MIAC message
1			
2			
3			
4			
.....	Input current = .....		

# Worksheet 2

## Lamps and simple actuators

## Sense and control in automotive systems



Typical light cluster



Wiper motor and linkage

There are many different kinds of lamps and actuators in an automotive system. Collectively these are known as 'output devices'.

Output devices need widely varying amounts of current.

As a result, there are a number of different circuits used to deliver current to, and control, ('drive') these output devices.

### Over to you:

1. Build the circuit shown opposite.
2. Set the power supply to 13.5V, plug into the Locktronics carrier, and switch on.
3. Press the switch to check that the bulb lights.
4. Connect a multimeter to read the current through the bulb. (A Multimeter Help Sheet is available if you are unsure how to do this.)
5. Select the 2A DC range, and press the red ON/OFF switch when you want to take a reading.
6. Press the switch and read the current through the bulb. Record the result in the table.

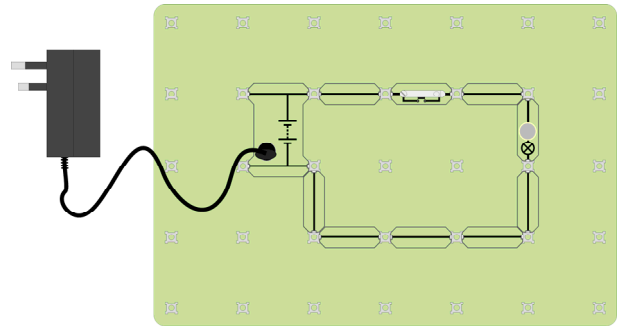

2a

Component	Current	Polarised?
Bulb		
Buzzer		
LED		
LED Bulb		
Motor		
Solenoid		

7. Replace the bulb with the other components listed in the table, in turn.
8. Some components work only when connected the right way round. Try each component both ways round in the circuit, and note which ones have this polarity.
10. Measure the current needed to drive each of these components.
11. Complete the table with your results.

There are several different types of bulbs and lamps in an automotive system. Each has different electrical properties and needs different circuitry. Confusingly, wiring diagram can use the same symbol for all of them.

Here are three examples:



Standard bulb

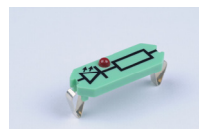

LED with current limiting resistor



LED bulb with internal current limiting resistor

# Worksheet 2

## Simple lamps and actuators

## Sense and control in automotive systems

### Over to you:

1. Build the system shown opposite.
2. Plug the power supply (set to 13.5V) into the Locktronics carrier, to power the full system.
3. Press the reset switch on the MIAC and select program 2.
4. Measure the current and complete the first row of the table.
5. Replace the LED with each of the two other types of lamp and measure the current.
6. Measure the current in the solenoid when the MIAC unit turns it on.

Component	Current
LED	
LED Bulb	
Standard bulb	
Solenoid	

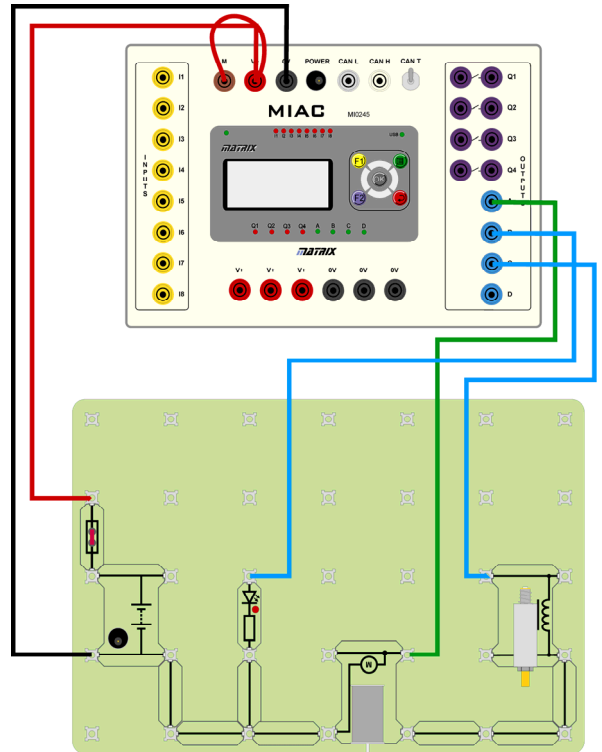

2b

ECUs have different types of outputs for driving devices with differing current demands.

This circuit uses the MIAC low current transistor outputs (labelled A to D).

Higher current devices will need to use the relay outputs, (labelled Q<sub>1</sub> to Q<sub>4</sub>).

Transistor outputs can vary the current delivered, which means they can alter lamp brightness and motor speed. Relay outputs are either on or off, and so cannot.

### More symbols and components

The motor, LED and buzzer are familiar objects. You may not have met the solenoid.

It consists of a electromagnet which pushes out the rod at its core when activated.

2c



Buzzer



LED

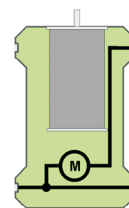

Motor

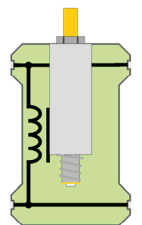

Solenoid

There are two sets of circuit symbols in common use:

- the European (DIN) symbols;
- the American (ANSI) symbols.

Many Locktronics components are available in either format.



Fuse



Resistor (Europe)



Resistor (USA)

1d

# Worksheet 3

## Using transistors

# Sense and control in automotive systems



Car radio



Transistors - they come in a variety of shapes and sizes!

The transistor is the building block of modern electronics.

You will not often see a 'stand alone' transistor in an automotive application, but they are there, embedded in radios, ECUs and other subsystems.

It is useful to understand how they work, and what their limitations are.

The most basic use of a transistor is to amplify current.

The ratio of output current to input current is known as the transistor current 'gain'.

### Over to you:

1. Build the circuit shown opposite.
2. Set the power supply to 13.5V, plug into the Locktronics carrier, and switch on.
3. Press the switch to check that the bulb lights.
4. Connect a multimeter, on the 2A DC range, to read the current through the 10kΩ resistor when the bulb is lit. This is the transistor **input** current
5. Move the meter to measure the current through the bulb. This is the transistor **output** current.
6. Press the switch and measure the bulb current.
7. Record your results in the table.
8. Replace the switch with the Hall effect sensor.

Wire the '+V' and '0V' terminals up and pass a magnet close to it. Does the circuit work in the same way?

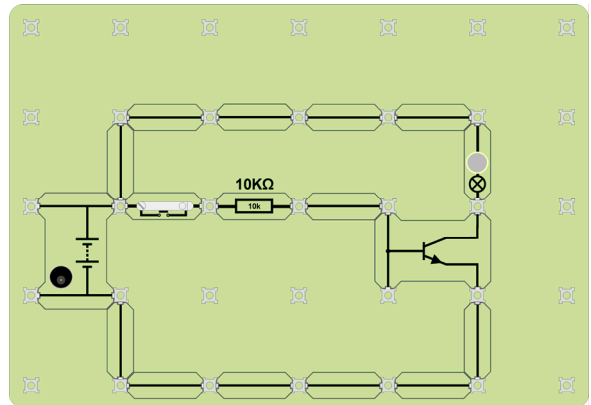

Transistor	Current
Input	
Output	

### New symbols and components

transistor

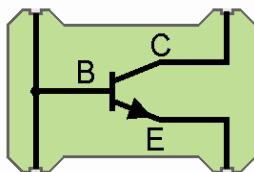

There are many types of transistor. This one is a 'NPN' transistor. The three terminals, shown on the symbol by the letters 'B', 'C' and 'E', are the base, collector and

Hall effect switch

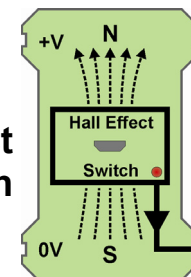

The Hall effect switch is turned on by a magnetic field. It is actually an integrated circuit. It is used to detect the proximity of mechanical devices and is fast to respond.

# Worksheet 3

## Using transistors

# Sense and control in automotive systems

### Over to you:

1. Build the system shown opposite.  
This is effectively the same circuit as on the previous page, but it uses a transistor found inside the MIAC.
2. Plug the power supply (set to 13.5V) into the Locktronics carrier, to power the full system.
3. Press the reset switch on the MIAC and select program 3.
4. Use a multimeter to measure the current through the switch, (transistor **input** current,) and then through the bulb (transistor **output** current.)
5. Record your results in the table.

Transistor	Current
Input	
Output	

6. Compare these results with those you obtained for the stand-alone transistor on the previous page.

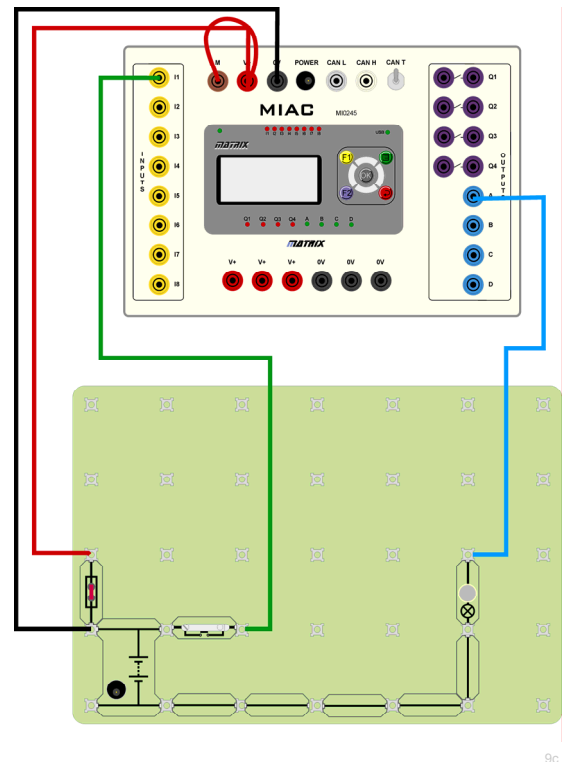

Inside the MIAC, each of the outputs A, B, C, D is controlled by an internal computer, connected to a power transistor.

The power supply for the computer is comes from the V+ terminals.

The power supply for the transistor outputs comes from the 'M' terminal.

For this reason you always need to connect the M terminal to V+ when you want to use the transistor outputs.

In practice the circuitry inside the MIAC, ( and an ECU,) is more complicated. The outputs have protection against short circuits, and against high voltages caused by inductive loads, such as motors and coils.

The 'M' terminal can be connected to any voltage supply, and does not have to use the MIAC power supply. This allows the transistors to switch higher voltages, such as the 24V supply found in a truck.

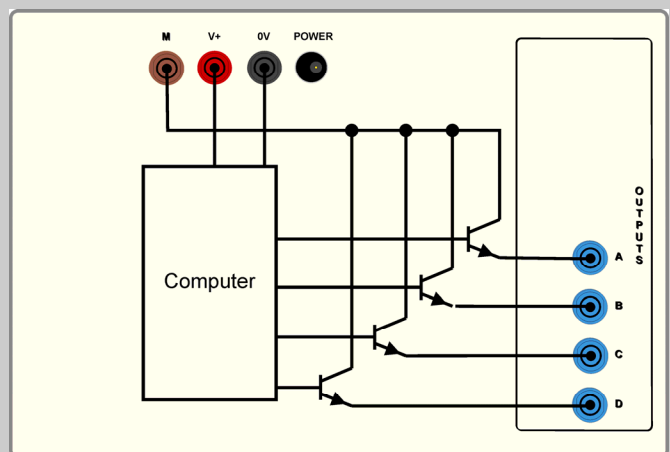

Wiring of the transistor outputs inside the MIAC.

# Worksheet 4

## Relays

### Sense and control in automotive systems



Typical starter motor relay  
- often called a 'solenoid'

A key function of the electronics in a car is to turn low current signals, from a switch or sensor, into high current signals to operate the output device.

The output current of transistors has a limit of a couple of amps at the most.

When higher currents are needed, we use relays.

High current systems in a car, (typically, more than 1 amp,) make use of relays in their driving circuits.

#### Over to you:

1. Build the circuit shown opposite, to investigate what a relay does.
2. Set the power supply to 13.5V, plug into the Locktronics carrier, and switch on.
3. Connect a multimeter, on the 2A DC range, to read the current **I1**, when the switch is pressed. This is the current through the coil that activates the relay, equivalent to the transistor input current.

4. Move the multimeter to measure the current **I2**, through the solenoid. This is the current delivered by the relay contacts to the output device, the solenoid in this case.

It is equivalent to the transistor output current.

3. Record your readings in the table.

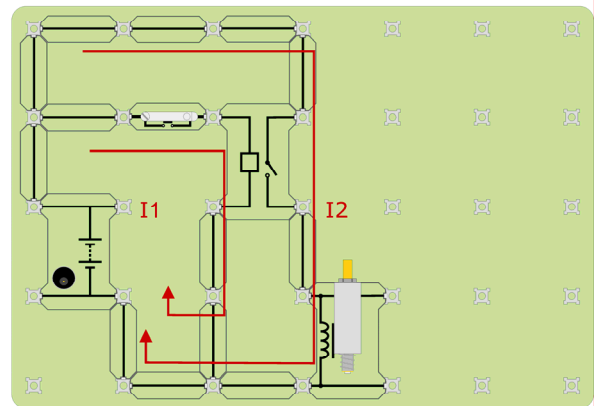

Relay	Current
Input, <b>I1</b>	
Output, <b>I2</b>	

#### New symbols and components

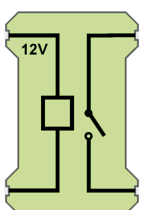

A relay consists of a small solenoid (coil,) used to control a switch located nearby, but electrically isolated from it.

When the solenoid is energised (i.e. a sufficient current flows through it,) it closes the switch.

In this way, it uses a low current to control a high one, up to 40A in a car.

# Worksheet 4

## Relays

## Sense and control in automotive systems

Here is an example of a simple system. Systems have an input, a processor, and an output. In this case, the system has only one of each. Systems can be much more complex!

Solenoid circuits like this one are used to operate electric door locks. There is a weakness! The car's computer (and driver) have no way of knowing whether the locking operation worked. If the mechanical linkage to the door lock is fouled in some way the car will be insecure, but the central locking system is not informed.

### Over to you:

1. Build the system shown opposite.
2. Plug the power supply (set to 13.5V) into the Locktronics carrier, to power the full system.
3. Press the reset switch on the MIAC and select program 4.
4. Check that the system is working by pressing the switch.
3. Use a multimeter, on the 2A DC range, to measure the current through the switch. This is the MIAC input current. You should find that it is much less than the input current of the relay in the previous worksheet.

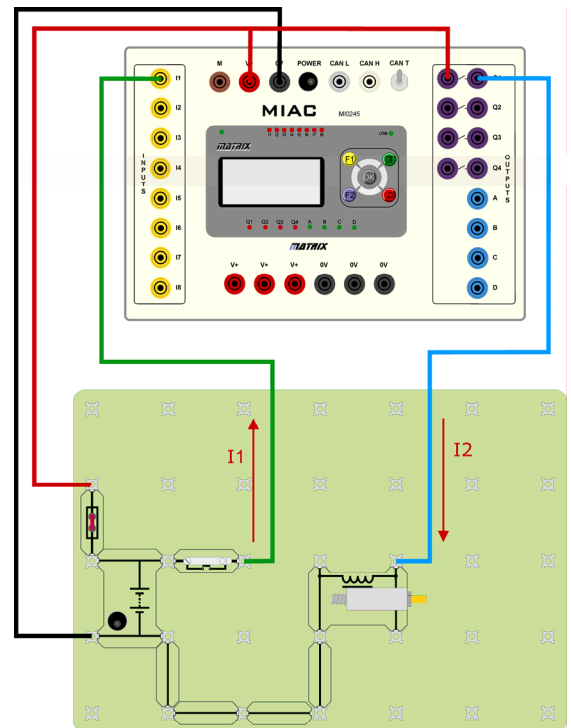

3b

Inside the MIAC, there are four relays connected to an internal computer. Only one relay is shown on this diagram.

Each relay has two terminals, with a switch symbol between them. Both terminals must be connected into the circuit. In the system above, the left-hand terminal is connected to the power supply V+.

Each relay is capable of switching up to 8 amps.

Relay outputs on ECUs have the advantage that they can switch high current, but have the disadvantage that they are quite slow to act, compared to transistors.

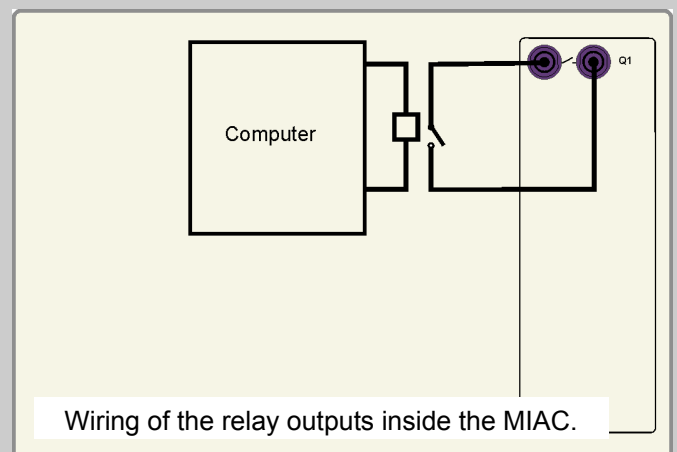

Wiring of the relay outputs inside the MIAC.

3d

# Worksheet 5

## Analogue inputs

# Sense and control in automotive systems



Fuel sensor with float

There are two types of sensor, **analogue** and **digital**, in a car.

Analogue sensors provide more information than just the sensor being 'on' or 'off' and can be used to more accurately interpret the state of a system. They provide information about how full?, how far?, how many?, how hot? etc.

Examples of analogue sensors include the fuel sensor on the fuel tank and the environmental temperature controller in the passenger space.

### Over to you:

- Build the system shown opposite.  
The potentiometer is an analogue sensor. It is equivalent to the fuel sensor in a car. Turning the potentiometer is like adding fuel to or taking it from the tank.  
When the fuel level drops too far, the LED lights to warn the driver.
- Plug the power supply (set to 13.5V) into the Locktronics carrier, to power the full system.
- Press the reset switch on the MIAC and select program 5.
- Connect a multimeter, set to the 20V DC range, to measure the output voltage of the potentiometer.
- Turn the potentiometer to change the output in regular one volt intervals.
- Record the corresponding fuel levels in the table.

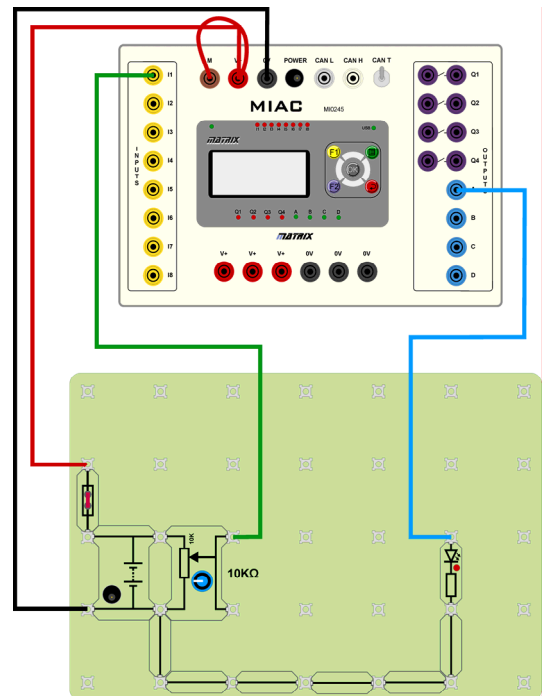

Input voltage (V)	1	2	3	4	5	6	7	8	9	10	11	12
Fuel level (l)												

- At what value does the 'low fuel' LED come on? \_\_\_\_\_.
- Twist the potentiometer quickly one side to another, to simulate fuel slopping around in the tank. Notice how quickly the readout on the MIAC changes. Is this a problem?
- Next, short circuit the output of the potentiometer to first 0V and then the supply voltage. To do this, connect a wire from the MIAC input I1 to first 0V and then to V+.
- Make a note of the reading of fuel level. You will use this information later.

0V: \_\_\_\_\_ V+: \_\_\_\_\_



# Worksheet 6

## Fault detection with ECUs

## Sense and control in automotive systems



In modern automotive systems, ECUs are used for much more than control. They can also report on the status of the vehicle and many of its components.

In this Volvo V70, the ECU has detected that the front headlight bulb is broken and has reported it to the dashboard so that the driver can replace it.

### Over to you:

- Build the system shown opposite. It contains features to monitor both the fuel level sensor and the headlamp bulb (the bulb connected to relay output B.)
- Plug the power supply (set to 13.5V) into the Locktronics carrier, to power the full system.
- Press the reset switch on the MIAC and select program 7.
- Connect a multimeter, set to the 20V DC range, to measure the output voltage of the potentiometer.
- Turn the potentiometer to change the output in regular one volt intervals. (It may not be possible to obtain all the values shown in the table.)
- Record the corresponding fuel levels in the table.

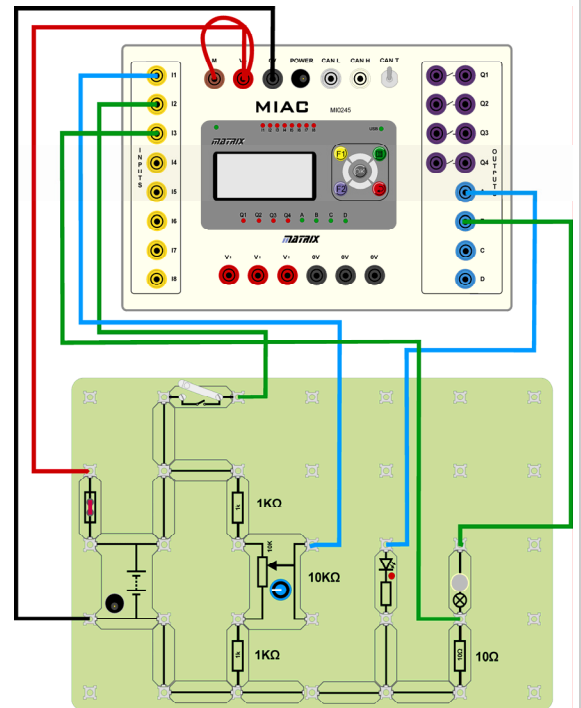

Input voltage (V)	1	2	3	4	5	6	7	8	9	10	11	12
Fuel level (l)												

- At what value does the 'low fuel' LED come on? \_\_\_\_\_.
- What is the difference between this and the previous program?

At this point, you are going to create a number of faults in the system. The circuit and software are set up to detect these.

### Fault 1: Short circuit to 0V

- Press the reset switch on the MIAC and select program 8.
- Short-circuit the potentiometer output to 0V (by making the extra connection, labelled 'A' on the diagram).
- What is shown on the MIAC display?

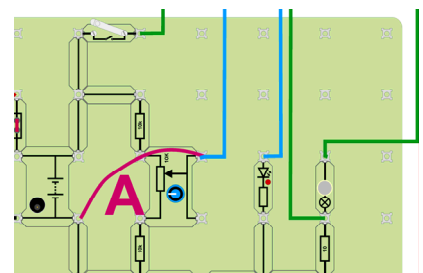

\_\_\_\_\_.

# Worksheet 6

## Fault detection with ECUs

## Sense and control in automotive systems

Step 5 in the previous exercise showed that the output from the 'fuel sensor' is never below 0.9V or above 11.6V.

Wire 'A' in the diagram short-circuits the fuel sensor output to 0V. When MIAC measures 0V, it knows that there is a problem with the fuel sensor and it can issue a fault warning.

### Over to you:

#### Fault 2: Short circuit to positive supply

12. Remove the short-circuit.
13. Press the reset switch on the MIAC and select program 8.
14. Next, short-circuit the potentiometer output to the positive supply terminal. To do this, connect a wire from the output of the potentiometer to one of the V+ terminals. This simulates a fault where the sensor output is connected, by accident, to the positive supply voltage in the car.
15. Verify that the fault is recognised by the MIAC.
16. Measure the voltage on MIAC input I2 and record it:

\_\_\_\_\_

#### Fault 3: Sensor output is open-circuit.

16. Remove the short-circuit.
17. Press the reset switch on the MIAC and select program 8.
18. Disconnect the lead from the potentiometer to the MIAC.
19. Verify that the fault is recognised by the MIAC.

With careful design of the system and software, it is possible to provide detailed information to the driver, and service centre, of the state of a system and its fitness for purpose.

However, it is not always possible for an ECU to diagnose the exact fault - an open-circuit for a sensor at the ECU can give the same electrical symptoms as a short-circuit.

#### Fault 4: A faulty headlamp bulb.

20. Press the reset switch on the MIAC and select program 8.
21. Connect a multimeter to measure the voltage across the 10Ω resistor.
22. Measure this voltage when the switch is pressed and the headlamp is lit: \_\_\_\_\_
23. Remove the bulb, to simulate a blown filament fault .
24. Press the switch and record the new voltage across the resistor: \_\_\_\_\_
25. Hence, describe how the MIAC ECU is able to detect this fault.

\_\_\_\_\_

# Worksheet 7

## Open loop vs closed loop

## Sense and control in automotive systems



Coolant temperature sensor - single resistor type

Mirror with internal light sensor



It is often difficult to recognise the full sensor circuit, as part of it could be inside the ECU itself.

This can make it harder to debug the circuit .

There are two main types of control systems in a car - **open loop** and **closed loop**. In a closed loop system, the output state of the system is fed back into the input, so that the system can check when the desired outcome has been attained.

### Over to you:

- Build the system shown opposite. It contains three analogue sensors - a potentiometer, a thermistors (temperature-dependent resistor) and a LDR (light-dependent resistor, and two output devices - a motor and a lamp. The motor represents the fan heater motor. The temperature inside the car is set using the potentiometer, and is sensed by the thermistors. The bulb represents the headlamps. It should switch on automatically when it gets dark. This is sensed by the LDR.
- Plug the power supply (set to 13.5V) into the Locktronics carrier, to power the full system.
- Press the reset switch on the MIAC and select program 9.
- Cover the LDR with your finger. What happens?
- Adjust the potentiometer so that the motor is just running.
- Use a multimeter to measure the voltage on the MIAC input connected to the thermistor
- Warm the thermistor between your fingers, to show what happens when the car interior gets hotter.. What happens to the voltage at the MIAC input? What happens to the motor?
- What happens as the thermistor cools down? (This represents the interior of the car cooling down.)

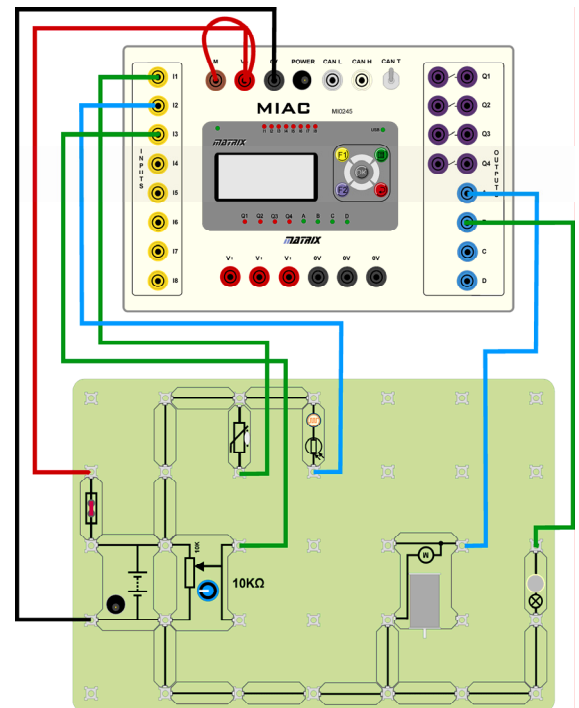

6b

# Worksheet 7

## Open loop vs closed loop

## Sense and control in automotive systems

The light sensor circuit is open loop. The sensor detects that it is dark enough, so that the headlamps should be turned on. However, the system cannot verify that this happens, that the light has reached a given brightness.

### Open loop control system

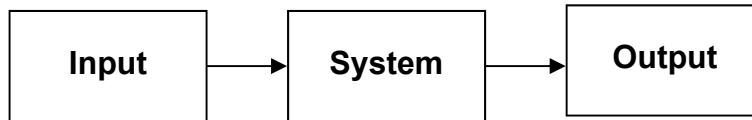

The thermistor circuit is closed loop. The fan heater warms the car up. A signal from the thermistor, indicating the current temperature, is fed back to the system and compared with the desired temperature, set by the potentiometer signal. The system can then know when the desired temperature has been reached.

### Closed loop control system

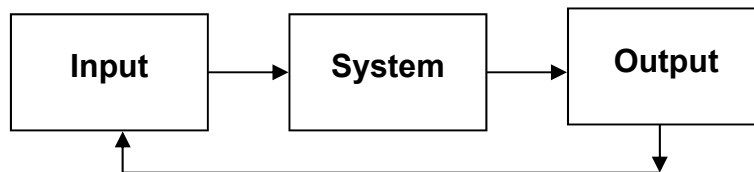

The circuit for the sensors is more complicated than is immediately apparent.

Each of the MIAC inputs has a 10K resistor connected to 0V.

This is the other part of the voltage divider, combined with a sensor connected to the positive supply. A change in the sensor resistance produces a change in voltage at the input.

This design has two advantages:

It reduces the component count outside the ECU.

It allows car manufacturers to use lower cost 'passive' rather than 'active' sensors.

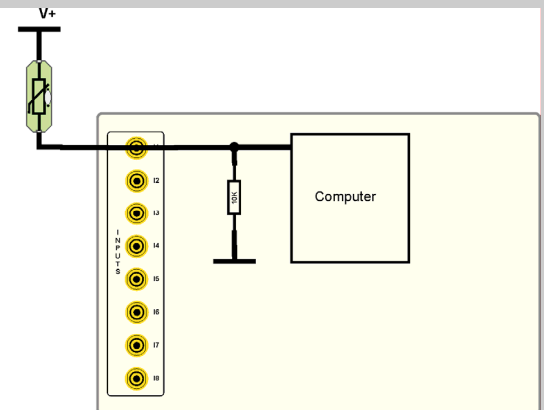

Wiring of the inputs inside the MIAC.

## New symbols and components

Thermistor



Light dependant resistor



6a

Some thermistors have a resistance that increases with temperature, (known as Positive Temperature Coefficient, PTC thermistors).

In others, resistance decreases as temperature increases. These are known as Negative Temperature Coefficient, NTC thermistors.

6c

# Worksheet 8

## Controlling DC motors

# Sense and control in automotive systems



Car seat motor with linkage

Electric window motor



So far we have considered circuits that provide only one level of power to a motor—turning it fully on or fully off.

However, in many situations, we want to control the speed of the motor and this requires a new technique.

To vary the speed of a motor you need to vary the **power** supplied to it. The two easiest ways of doing this are to vary the voltage, or vary the **duty cycle** of the motor supply. Varying the duty cycle is the most common method and this is explained here.

### Over to you:

- Build the system shown opposite. It contains a switch, a potentiometer and a motor. The motor represents the windscreen wiper motor and the potentiometer controls the wiper speed.
- Plug the power supply (set to 13.5V) into the Locktronics carrier, to power the full system.
- Press the reset switch on the MIAC and select program 10.
- Close the switch to turn the wipers on. Check that the motor speed is controlled by the potentiometer.
- For two settings of the potentiometer, one where the motor runs slowly and the other where it runs fast, monitor the waveform on the output of the MIAC on an oscilloscope. Sketch the waveforms on the diagrams below. Label each with significant voltages and times.

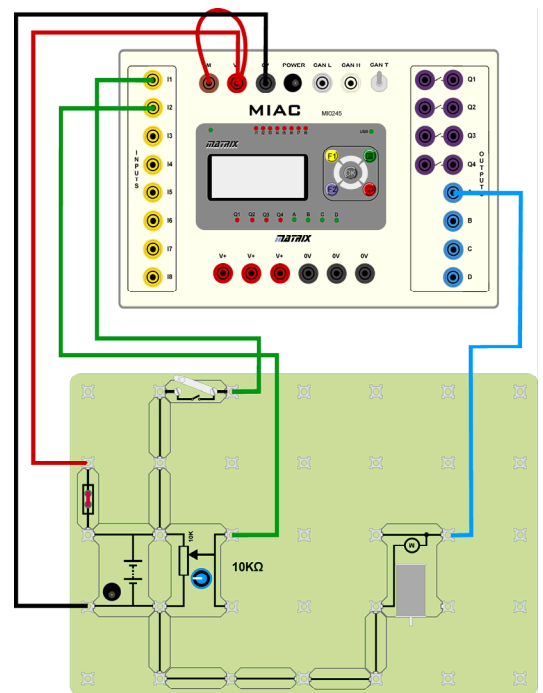

7a

**Slow**

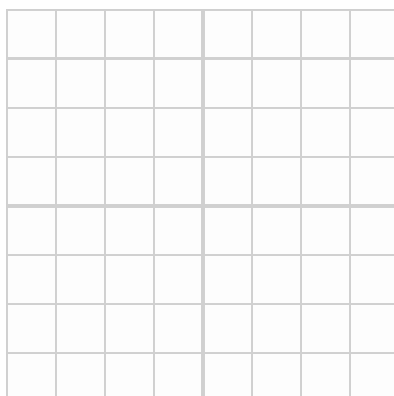

7b

**Fast**

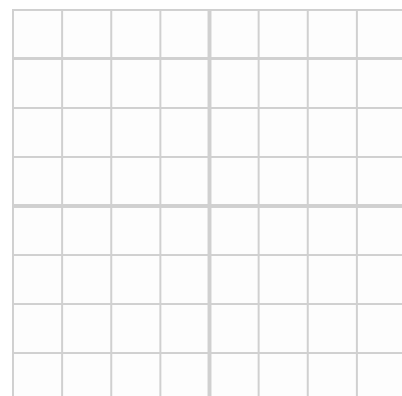

7b

# Worksheet 8

## Controlling DC motors

## Sense and control in automotive systems

Using the **first** form of speed control:

- when the MIAC output is a constant 0V then there is power supplied to the motor;
- when the MIAC output is a constant 12V then maximum power is supplied to the motor.

Using the **second** form, the motor speed is varied by pulsing the output to the motor.

In the first oscilloscope trace, on the right, you can see that the output is seldom on, so that the power transferred is small, and the resulting speed is low.

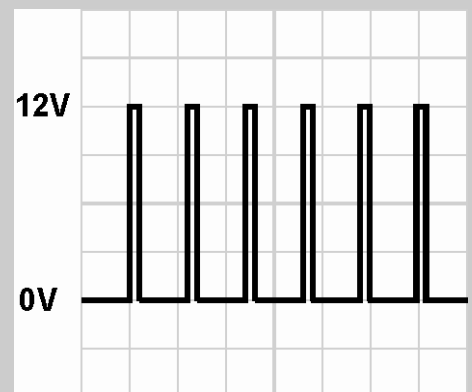

In the second trace, the output is mostly on, so that the power supplied to the motor, and the resulting speed, is high.

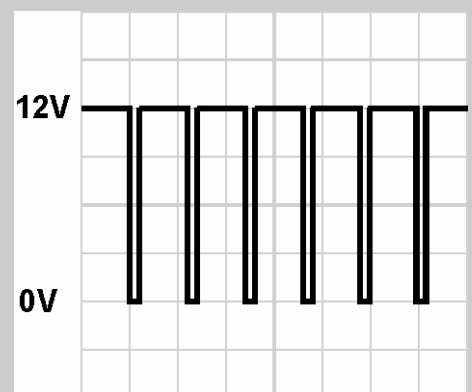

This technique of pulsing the output to vary the speed is known as Pulse Width Modulation (PWM.)

The ratio of the time for which the pulse voltage is high to the time for which the pulse voltage is low is called the '**duty cycle**'.

# Worksheet 9

## Controlling stepper motors

## Sense and control in automotive systems



Idle valve stepper motor

DC motors are cheap and reliable but cannot be used in systems which need a measured and precise amount of movement or rotation.

Then, stepper motors are used .

Stepper motors use four internal coils. As the name suggests, these allow the rotor to be moved in small steps - forwards or backwards. Stepper motors vary in the number of steps they provide in one full rotation. The stepper motor we use takes 96 separate steps per revolution, giving it a positional accuracy of 3.75 degrees.

### Over to you:

1. Build the system shown opposite.
2. Plug the power supply (set to 13.5V) into the Locktronics carrier, to power the full system.
3. Press the reset switch on the MIAC and select program 11.
4. The four switches represent forwards, backwards, memory and recall. Check that they work correctly.

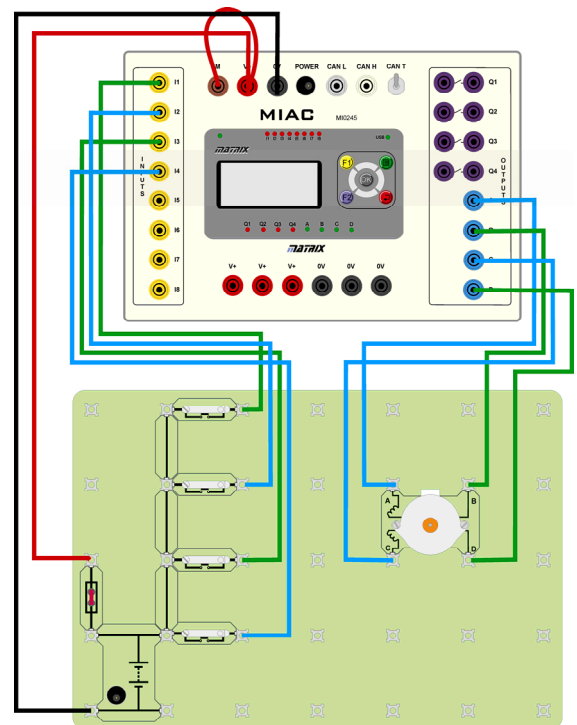

8a

# Worksheet 9

## Controlling stepper motors

# Sense and control in automotive systems

Over to you:

- For eight steps of the motor going forward (clockwise), measure the voltages at the MIAC outputs, A, B, C, D.
- Fill in the table using a '1' to represent V+ and a '0' to represent 0V. (Hint - you can use the LEDs on the MIAC unit.)

	A	B	C	D
Step 1				
Step 2				
Step 3				
Step 4				
Step 5				
Step 6				
Step 7				
Step 8				

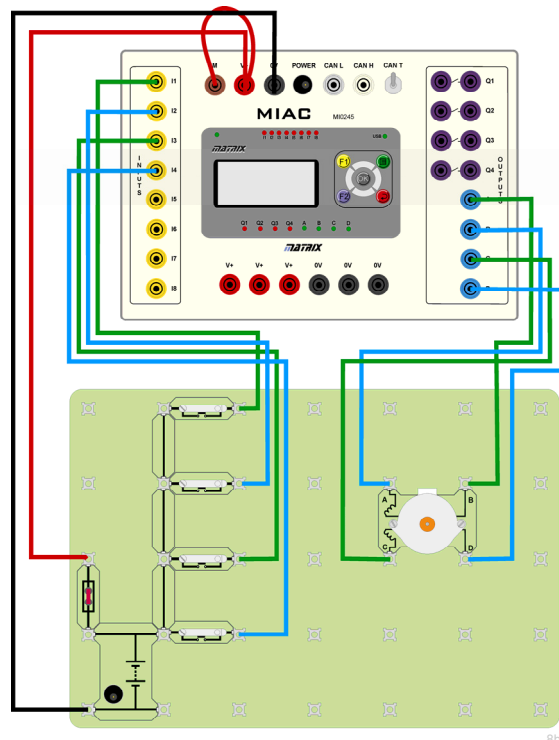

- The direction a stepper motor moves in is dictated by the sequence of voltages on the four coils. In completing the table, you observed the forward pattern. Confirm that when you reverse the motor, this pattern is simply reversed.
- Change the connections to the stepper motor. Connect A on the MIAC to B on the stepper, and B on the MIAC to A on the stepper. What happens when you try to make the motor go forward or backwards?

### New symbols and components

Stepper motor

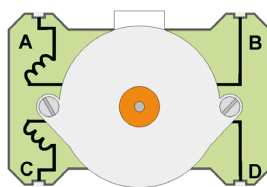

# Instructor Guide

## Sense and control in automotive systems

### About this course

#### Introduction

The course is essentially a practical one. Locktronics equipment makes it simple and quick to construct and investigate electrical circuits. The end result can look exactly like the circuit diagram, thanks to the symbols printed on each component carrier.

#### Aim

The course aims to introduce students to sensing and control circuits in motor vehicles.

#### Prior Knowledge

It is recommended that pupils have followed the 'Electricity Matters 1' and 'Electricity Matters 2' courses, or have equivalent knowledge and experience of building and analysing simple circuits.

#### Learning Objectives

On successful completion of this course the pupil will have learned:

- to distinguish between analogue and digital sensors;
- that simple digital sensors have a two-state output - either open (off) or closed (on);
- that digital sensors have a high resistance when open, and a small resistance when closed;
- that simple digital sensors output a signal either at 0V or at the full power supply voltage;
- the circuit symbols for a range of switches, bulbs and sensors;
- that some components are polarised, so that they work properly only when connected the right way round;
- that an ECU can be programmed to recognise a high input voltage as the switch being either 'on' or 'off';
- that output devices require a variety of current levels to make them operate;
- that transistors are current amplifiers, with a current gain defined as output current divided by input current;
- that transistors have three terminals, named base, collector and emitter;
- that transistors can be used to deliver currents up to around 2A;
- that relays can be used to deliver currents up to around 40A in a car;
- that transistors are much faster than relays in switching on and off;
- how to connect MIAC to deliver current through its transistor output terminals;
- how to connect MIAC to deliver current through its relay output terminals;
- that electronic systems consist of three elements, input, process and output subsystems;
- that analogue sensors output a continuous range of voltages;
- that a capacitor can be used to dampen the reading from an analogue sensor;
- that a potentiometer can set a reference voltage to determine quantities such as the temperature inside a car;
- that an ECU can be used to monitor the status of a vehicle and its components;
- that there are two types of control system, open-loop and closed-loop;
- that the speed of a motor can be controlled by varying the duty cycle of a square wave signal applied to it, using a process called pulse-wave modulation (PWM);
- the advantage of a stepper motor over a simple DC motor;
- that a stepper motor rotates through a specific angle each time that the coils are energised in the correct sequence;

# Instructor Guide

## Sense and control in automotive systems

### What the student will need:

To complete this course the student will need the equipment in the table.

### Additional documents

The instructor will need to refer to the following before starting this course:

Locktronics User Guide - explains how the Locktronics system works, and how to use the parts.

MIAC Getting Started Guide - explains how the MIAC unit works, how to download Flowcode programs to it etc.

### Power source:

The mains-powered 'plug-top' power supply can be adjusted to output voltages of either 3V, 4.5V, 6V, 7.5V, 9V or 13.5V, with currents typically up to 1A. The voltage is changed by turning the selector dial just above the earth pin until the arrow points to the required voltage. The course uses the 13.5V setting exclusively. However any power supply can be used. If you prefer your students to work from exactly 12V then please use a bench top power supply.



Qty	Code	Description
1	HP2045	Shallow plastic tray
3	HP4039	Lid for plastic trays
1	HP5328	International power supply with adaptors
1	HP5540	Deep tray
2	HP7750	Locktronics daughter tray foam insert
1	HP9564	62mm daughter tray
1	HPUAB	USB AM to BM mini lead
1	LK0123	Magnet
1	LK2363	MES bulb, 14V, 0.06A
1	LK2871	Locktronics Warranty Document
1	LK3246	Buzzer (12V)
1	LK4000	Locktronics User Guide
1	LK4025	Resistor - 10 ohm, 1W 5% (DIN)
1	LK4322	Stepper Motor
1	LK4786	Automotive fuse carrier
1	LK5100	Locktronics current probe
1	LK5144	Light dependent resistor (DIN)
2	LK5202	Resistor - 1K, 1/4W, 5% (DIN)
1	LK5203	Resistor - 10K, 1/4W, 5% (DIN)
1	LK5214	Potentiometer, 10K (DIN)
1	LK5241	Transistor - NPN, left hand feed
16	LK5250	Connecting Link
1	LK5280	Relay 12V 10A (transparent case)
1	LK5287	Automotive lampholder
1	LK5291	Lampholder carrier
1	LK5402	4.7K thermistor, NTC (DIN)
1	LK5603	Lead - red - 500mm, 4mm to 4mm stackable
1	LK5604	Lead - black - 500mm, 4mm to 4mm stackable
6	LK5607	Lead - yellow - 500mm, 4mm to 4mm stackable
6	LK5609	Lead - blue - 500mm, 4mm to 4mm stackable
4	LK6207	Switch Press (morse key-type strip, push to make)
2	LK6209	Switch on/off (stay put, sideways swivel strip)
1	LK6430	LED, red, 12V (DIN)
1	LK6492	Curriculum pack CD ROM
1	LK6634	Microswitch
1	LK6653	Capacitor, 4,700 uF, Electrolytic, 16V
1	LK6706	Motor 3/6V D.C. 0.7A
1	LK6734	Hall Effect Switch carrier
1	LK6838	Solenoid
1	LK6841	MES bulb, 12V, LED, white
1	LK8275	Power supply carrier with battery symbol
1	LK8900	7 x 5 baseboard with 4mm pillars
1	MI0245	Cased MIAC with 4mm sockets
1	TEFLCSI3	Flowcode V3

# Instructor Guide

## Sense and control in automotive systems

### Using this course:

Our goal is to help students understand sensors and control systems in the context of automotive systems - to understand the components, the circuit diagrams, and the role of the Electronic Control Unit (ECU). We do this by asking students, working individually or in pairs, to build a number of circuits typically found in an automotive system that use an ECU. Students select an ECU program that makes the circuit work in the desired way, and then take measurements, make drawings, or describe what is happening in the circuits, to reinforce learning.

Central to these activities is the MIAC Electronic Control Unit (ECU). This flexible educational ECU mimics the functionality of the ECUs found in automotive systems. The instructor should make sure that all ECUs are pre-programmed with the appropriate Flowcode file, LK2209.fcf. Details on how to load this file are found in the MIAC 'Getting Started' guide.

It is expected that the worksheets are printed / photocopied, preferably in colour, for the students' use. Students will need their own permanent copy, as a record of what they have learned.

Each worksheet has:

- an introduction to the topic under investigation;
- step-by-step instructions for the investigation that follows;
- a summary of the important points in a grey-filled text box

This format encourages self-study, with students working at a rate that suits their ability. It is for the instructor to monitor that students' understanding is keeping pace with their progress through the worksheets. One way to do this is to 'sign off' each worksheet, as a student completes it, and in the process have a brief chat with the student to assess their grasp of the ideas involved in the exercises it contains.

### Time:

It will take students between six and seven hours to complete the worksheets. It is expected that a similar length of time will be needed to support the learning that takes place as a result.

# Instructor Guide

## Scheme of Work

## Sense and control in automotive systems

Worksheet	Notes for the Teacher	Timing
1	<p>The course aims to start simple, and ramp up in demand as it develops. The simplest sensors are those that either 'On' or 'Off'. These are known as simple digital sensors, as they exist in one of only two possible states. Usually, these states are represented by voltage signals, so that 0V may mean 'Off' while 12V means 'On'. (This depends on the way the circuit is set up. It is possible to create a system where 0V means 'On' and 12V means 'Off!')</p> <p>In contrast, an analogue sensor outputs a signal, usually a voltage, that can have any value from 0V to 12V, in the context of a car. The outside world is largely analogue. The air temperature can be any value, from minus quite a few °C to plus quite a few. It is not simply 'Hot' or 'Cold'. Similarly for pressure, light intensity, humidity, sound level etc. The more complicated situation of analogue sensors is tackled later, in worksheet 5. An analogue sensor produces a voltage analogy of what it is measuring - the higher the temperature, the higher the voltage, for example. The instructor might like to expand on the differences between analogue and digital quantities, or could direct the students to a website such as Wikipedia.</p> <p>Students are required to use a multimeter to measure first voltage, then resistance and finally current, in this worksheet. It is assumed that they have prior experience of this. A Help Sheet is provided to remind them of how to proceed. The instructor should bear in mind that many multimeters have internal fuses to protect them when set on 'current' ranges. Misuse may lead to these fuses blowing. There is usually no external indication of what has happened - the meter just refuses to measure current. It is worthwhile checking each multimeter beforehand, and having a supply of the fuses available during the practical sessions. When measuring resistance, the multimeter applies a low voltage to the component and uses the resulting measurement of current to compute a value for resistance. It is vital that the component is not connected in a circuit while this is taking place.</p> <p>At the end of this worksheet, students are introduced to MIAC (Matrix Industrial Automotive Controller), which simulates the behaviour of an ECU (Electronic Control Unit) in a car. The MIAC is pre-programmed using Flowcode, a graphical programming language, with all the routines used in the course. No Flowcode programming is needed in the course. Some students may be interested in how this language works. Further information is available on the MatrixMultimedia website. The final exercise introduces a number of different types of switch. The symbols for these are shown, so that students can begin to learn them. Current measurement in any one shows that only tiny currents are needed from these sensors. If the system is not working, it may be that the fuse is faulty. The students could use the multimeter to measure the resistance of the fuse, disconnected from the rest of the circuit, to see if this is the problem. Otherwise, they should check the wiring.</p>	40 - 60 minutes

# Instructor Guide

## Scheme of Work

## Sense and control in automotive systems

Worksheet	Notes for the Teacher	Timing
2	<p>The aim here is to show that output devices need much higher currents than are seen in the sensors, and that a variety of techniques and components are needed to supply that current - 'drive' the output devices, as the jargon has it.</p> <p>The worksheet begins by getting students to measure the current needed by a range of output devices. Instructors should note the point made in the previous section about the internal fuses used by multimeters set on current ranges. Students should be informed that there is a wide range of output devices, solenoids, for example, each of which has its own particular current requirement, which may be different from the 'Locktronics' component. They should be encouraged to study some data sheets for common car components to see this in action.</p> <p>The point is raised that some components are polarised, i.e. that they work only when connected the right way round in a circuit. This is especially true of LEDs and capacitors., which can be damaged if connected the wrong way round. The students are asked to list in the table the components that are polarised .</p> <p>The second page of the worksheet introduces the difference between transistors and relays, as current drivers. It also points out the two systems of symbols, European and American, used in circuit diagrams. The instructor might direct the students to find out more about the two systems, as they may meet both in investigating car electrics.</p> <p>The worksheet provides more examples of circuit symbols for common components.</p>	40 - 60 minutes
3	<p>Transistors are highly complex devices, which rely on some advanced semiconductor physics. The treatment here is based on using transistors to interface output devices to the ECU, so that they receive the current they need to operate.</p> <p>The idea of current gain is investigated. Students measure the input (base) current, and the output (collector) current. The current gain tells us how many times the output current is greater than the input current. (If the current gain is 50, then an input current of 0.01A will control an output current of 0.5A.) Some students will misunderstand 'gain' as meaning what is <i>added to</i>, whereas it means what is <i>multiplied by</i> the input current.</p> <p>In reality, transistors are widely used, but are embedded inside more complex systems, like the ECU, and so are rarely seen as discrete components. The second part of this worksheet shows students how to wire up the transistor outputs of the MIAC. In particular, it looks at the use of the 'M' terminal. As the diagram shows, this provides the positive voltage supply to the output transistors. It must be connected either to the V+ terminal of the MIAC, in which case it delivers the positive supply voltage used in the MIAC system (13.5V in our case,) or to an external power supply, in which case it delivers the voltage set on that. In the latter case, the 0V output of the external supply must be connected to one of the 0V terminals on the MIAC.</p>	40 - 60 minutes

# Instructor Guide

## Scheme of Work

## Sense and control in automotive systems

Worksheet	Notes for the Teacher	Timing
4	<p>This builds on the point that transistors have a limited current availability, and are not suitable as drivers for output devices that demand very high current.</p> <p>The worksheet begins by looking at the currents flowing in a relay circuit. The structure of a relay is described. When a small current flows through the relay coil, it magnetises the ferrite core, which then attracts the contacts of the separate switch, making them close. The instructor should emphasise that, although they are linked magnetically, the switch contacts are insulated from the relay coil circuit. These switch contacts can then be used in a separate circuit, like any other switch. The current available is limited only by the ability of whatever power supply is used (and the current rating of the contacts and connecting cables.)</p> <p>Then the equivalent system inside the MIAC is examined. A diagram shows how the MIAC relay outputs are controlled internally. This time, the 'M' terminal is not used. The MIAC offers two switch contacts on each relay output. These are used like any other switch - both contacts must be connected into the driver circuit. As relays are mechanical devices, with moving parts, they are slower to open and close than transistors, and will wear out because of friction. They are also considerably bigger than transistors, but on the other hand, can deliver higher currents.</p>	40 - 60 minutes
5	<p>As pointed out earlier, analogue sensors offer a voltage copy of whatever they are measuring. In the case of the fuel level sensor, the higher the fuel level, the higher the voltage. This allows us to introduce a trigger level, so that if the fuel level (and analogue sensor voltage,) falls too far, a warning LED can be switched on.</p> <p>The MIAC is programmed to convert the signal voltage from the fuel sensor into a fuel volume reading. Obviously, in real life, this would take into account the shape of the fuel tank.</p> <p>A problem that arises is that, since the fuel is in liquid form, it moves around in the tank as the vehicle moves. We do not necessarily want to see this movement on the fuel reading. In the first version of the circuit, changing the signal from the fuel level sensor, by twisting the shaft on the potentiometer rapidly, affects the fuel reading. To overcome this, a large capacitor is connected in parallel with the sensor. This stores electrical charge. The voltage across the capacitor can change only when electric charge has flowed out of, or on to the capacitor. This cannot happen rapidly. As the output voltage of the sensor changes, the capacitor acts to dampen any rapid changes in voltage.</p> <p>In the second part, the same effect is achieved using software, i.e. by altering the program running on the MIAC. This does away with the need for extra hardware, and shows one advantage of using ECUs. (In a similar way, the suspension in a car can be varied using software, to change from a 'sports' to a 'touring' response.)</p>	40 - 60 minutes

# Instructor Guide

## Scheme of Work

## Sense and control in automotive systems

Worksheet	Notes for the Teacher	Timing
6	<p>The first part modifies the analogue sensor used in the previous investigation by adding two resistors, one above and one below the potentiometer. As a result, the output of this 'fuel level sensor' does not have as big a range as before. It cannot output 0V, nor the full positive supply voltage. The fuel volume / sensor output table is different from that in the previous investigation, as a result. More importantly, the MIAC now knows that receiving a 0V signal, or a full V+ signal from the sensor is not possible, and must indicate a fault.</p> <p>The student creates these faults by connecting the potentiometer output first to 0V and then to V+ to show that MIAC will interpret these signals as faulty. Equally, the open-circuit condition in Fault 3 triggers a fault. The system designer makes decisions about which faults to detect, and what amount of detail to report to the driver. For example, does the driver need to know which car door has not closed properly (i.e. does it make any difference to the response,) or is it sufficient to know that one of the doors has not closed properly? (The instructor might wish to raise examples like this for students to debate as a group or decide on individually.)</p> <p>The circuit has been given the ability to detect when a headlamp bulb is faulty, so that the driver can be warned. To do this, a small resistor is connected in series with the bulb. If the bulb behaves normally, it passes a high current, which in turn sets up a measurable voltage across the resistor. When the bulb is faulty, there is no current and so no voltage across the resistor. One of the MIAC inputs looks at the voltage across this resistor, and so can sense when the headlamp bulb fails.</p> <p>The designer could incorporate similar sensors onto all components, but at a cost. In reality, a compromise is struck between reducing cost and monitoring 'mission-critical' components, but this is a design decision.</p>	40 - 60 minutes
7	<p>Many sensor circuits use the voltage divider principle. When two resistors are connected in series across a voltage supply, each takes a share of the voltage that depends on its resistance. When one of them is a sensor, such as a light-dependent resistor, a change in the light level causes a change in the LDR resistance, which, in turn, causes a change in the voltage across the LDR. This can then change the output voltage from the sensor.</p> <p>However, it can be more convenient to house the second part of the voltage divider within the ECU, or in this case MIAC, rather than next to the sensor. As a result, it can be difficult to investigate the full sensor circuit.</p> <p>This investigation looks at the extensive topic of open and closed loop control systems - another rich area for student research.</p> <p>In an open loop control system, the system has no way of knowing whether the desired outcome has been achieved. For example, switching on a washing machine may cause it to run through the same programme and for the same time whether there are any dirty clothes in the washer, or not, and regardless of how dirty the clothes are. A closed loop control system receives feedback which allows it to know when the desired outcome has been reached. In the case of a washing machine, the aim is to clean the clothes. If a sensor detected how clean the clothes were, it could control how long the washing machine programme ran.</p>	40 - 60 minutes

# Instructor Guide

## Scheme of Work

## Sense and control in automotive systems

Worksheet	Notes for the Teacher	Timing
8	<p>This worksheet contrasts two techniques for controlling the speed of a DC motor, for example the windscreen wiper motor. One controls the voltage applied to the motor, the second controls the duty cycle of a PWM (pulse-width modulated) voltage supply.</p> <p>The first method usually involves dropping some of the supply voltage across a variable resistor, and delivering the rest to the motor. When appreciable currents are involved, this means that high levels of power dissipation can occur in the variable resistor. At best, this is a very inefficient method.</p> <p>The second method has the advantage that the supply pulses between on or off. In either case, there is very little power dissipation in the switching circuit itself. (Power dissipated = current x voltage. When a switch is on, the voltage across it is zero, ideally, and so no power is dissipated. When a switch is off, the current is zero, and so no power is dissipated.)</p> <p>The PWM waveform is generated by the MIAC. The duty cycle depends on the DC voltage signal which the MIAC receives from the potentiometer. The investigation uses an oscilloscope to examine the PWM waveform, enabling students to calculate the duty cycle at two motor speeds. Sample traces of two duty cycles are provided on the second page. These could be used in sample calculations of duty cycle.</p>	40 - 60 minutes
9	<p>In some situations, we need precise control of how far a motor has rotated, or how fast it is going.</p> <p>One approach would be to attach an optically encoded disc to give feedback on the position, or speed of the motor. This would give a closed loop control system.</p> <p>Another is to use a stepper motor, which, as its name suggests, advances in steps, making one step each time that a particular series of pulses is received. This is an open loop system - there is no feedback.</p> <p>This worksheet looks at stepper motors. Students could be given the task of researching the inner workings of the stepper, or looking at datasheets for a range of devices, and matching them to particular tasks.</p> <p>The MIAC generates the required pulses and delivers them to the appropriate coil, depending on which switch is pressed. A problem occurs (the motor simply twitches) if the coils are not pulsed in the correct sequence. This is the focus of the second part of the worksheet, where the stepper is wired incorrectly. As there is no feedback, the MIAC has no way of knowing whether the motor is turning or not.</p>	40 - 60 minutes

# Using a multimeter

## Sense and control in automotive systems

A multimeter can measure either AC or DC quantities.  
The following symbols are used to distinguish between the two:



### Measuring voltage

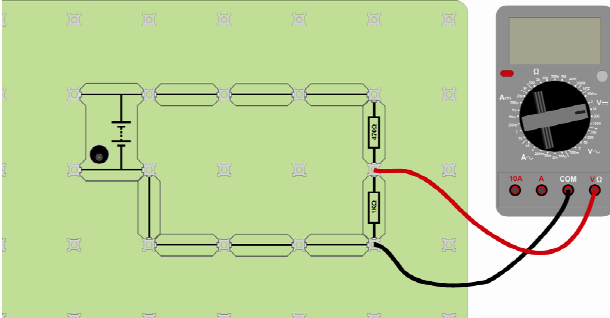

- Plug one wire into the black COM socket.
- Plug another into the red V socket.
- Select the 20V DC range by turning the dial to the '20' mark next to the 'V'  symbol.
- Plug the two wires into the sockets at the ends of the component under investigation.
- Press the red ON/OFF switch when you are ready to take a reading.
- If you see a '-' sign in front of the reading, it means that the wires from the voltmeter are connected the wrong way round. Swap them over to get rid of it!

### Measuring resistance

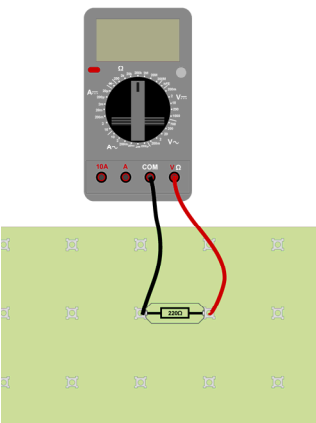

You cannot measure the resistance of a component while it is in the circuit. It **must** be removed first.

- Plug one wire into the black COM socket, and the other into the V  $\Omega$  socket.
- Select the 200k $\Omega$  range, (or a range which is much higher than the reading you are expecting.)
- Plug the two wires into the sockets at the ends of the component under investigation.
- Press the red ON/OFF switch when you are ready to take a reading.
- Turn the dial to choose a lower range, until you find the reading.

### Measuring current

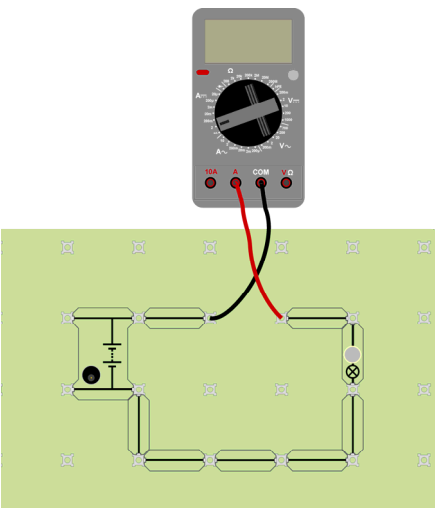

- Plug one wire into the black COM socket.
- Plug another into the red mA socket.
- Select the 200mA DC range by turning the dial to the '200m' mark next to the 'A'  symbol.
- Break the circuit where you want to measure the current, by removing a link, and then plug the two wires in its place.
- Press the red ON/OFF switch when you are ready to take a reading.

#### A possible problem!

The ammeter range is protected by a fuse located inside the body of the multimeter. This fuse may have 'blown', in which case the ammeter range will not work. Report any problems to your teacher so that they can check the fuse.