

Practical Teaching Ideas

With Multisim 10

7th Enlarged Edition

Tracy Shields

Incorporating teaching ideas developed by

Don Browning for Electronics Workbench v.5

About the Author

Tracy Shields is an electrical engineer who began her 25-year career in electronics as a technician working in service departments of electronic suppliers. She has 10 years of teaching experience in the Electronics Department at Seneca College, Toronto, Ontario. Along with her Electrical Engineering degree, Tracy has Electronics Computer Technician and Electronics Communication Technology diplomas providing her with a rich array of theoretical design and hands-on experience. Tracy currently provides electronic circuit design for engineering companies and consulting services on a number of topics in the field of computer and communications technology. Tracy Shields is the author of *RF Communications with Multisim* and *Electronics for Physics Students with Multisim*, also published by Electronics Workbench Corporation.

Practical Teaching Ideas (7th edition)

The reader is expressly warned to consider and adopt all safety precautions that might be indicated by activities described herein and to avoid all potential hazards. By following the instructions contained herein, the reader willingly accepts all risks in connection with such instructions.

National Instruments Corporation makes no representations or warranties of any kind, including but not limited to, the warranties of fitness for a particular purpose or merchantability, nor are any such representations implied with respect to the material set forth herein, and takes no responsibility with respect to such material. National Instruments Corporation shall not be liable for any special, consequential or exemplary damages resulting, in whole or in part, from the reader's use of, or reliance upon, this material.

Multisim and the Electronics Workbench name and logo are registered trademarks of Electronics Workbench Corporation. All trademarks are properties of their respective owners.

Other Contributors

The sections of this book pertaining to NI ELVIS were contributed by Jordan Randall, Laura Feeney, Matthew Slaughter, Missy Dodd, Mark Kaschner, and Megan Beck of National Instruments Corporation, Austin, Texas.

Edited by John Olley and Evan Robinson, Electronics Workbench Corporation.

For more information contact

Electronics Workbench Corporation
111 Peter Street, Suite 801
Toronto, Ontario, Canada M5V 2H1
Internet: www.electronicsworkbench.com
Phone: (416) 977-5550 Fax: (416) 977-1818

Permission is granted to reproduce any of the worksheets provided in this book, for educational purposes only. The Multisim circuits may be copied for classroom use. No other part of this publication may be reproduced or used in any form or by any means without prior written permission of the publisher, National Instruments Corporation. This publication is copyrighted and therefore protected by law in Canada and in the United States and under international treaty provisions.

I would like to dedicate my contribution to this book to my parents,
Marjorie and Ken

Table of Contents

Introduction

A Note for Instructors About the Purpose of this Book.....	1-1
About Multisim and LabVIEW	1-2
Relationship Between the Book and Circuit Files	1-3
Theory Enhancement	1-4
Lab Simulations	1-4
Labs on the Bench.....	1-4
As Real as it Gets.....	1-5
Lab for the Instructor.....	1-5

Section 1: DC and Thevenin's Theorem

Introduction to Section 1	1-9
Reinforcing Concepts of Basic Circuit Behavior	1-10
Agilent Multimeter	1-12
Voltage Controlled Current Source and Three Phase Source	1-13
Using a Variable Resistor and a Switch to Change Values	1-14
Voltage Controlled Resistor	1-16
Rated Components.....	1-17
Thevenin's Theorem.....	1-18
Worksheets	1-23

Section 2: Oscilloscope and Filters Introduced with the Bode Plotter

Introducing the Oscilloscope.....	2-3
Introducing the Bode Plotter	2-5
The Low-Pass Filter.....	2-7
Series RLC Resonant Circuit as a Filter	2-9
Simultaneous Comparison: Active and Passive Filters.....	2-11
Agilent Oscilloscope	2-12
Wizard	2-13
Worksheets.....	2-15

Section 3: Diodes

Introducing Diodes.....	3-2
Worksheets.....	3-3

Section 4: Transistors

Introducing Bipolar Transistors	4-2
FET Characteristics: Drain and Transconductance	4-4
Worksheets.....	4-5

Section 5: Troubleshooting and Problem Solving

Real-World Challenges in a Simulated Environment	5-3
Troubleshooting Activities.....	5-4
Puzzles: Thinking With Knowledge.....	5-5
Problem Solving Techniques	5-6
The Bridge Between Problem Solving and Design	5-8
Troubleshooting Activities.....	5-11

Section 6: Operational Amplifiers

Introducing Op-Amps.....	6-2
Worksheets.....	6-3

Section 7: Thyristors and Switches

Introducing Thyristors and Switches.....	7-2
Worksheets.....	7-3

Section 8: Digital Circuits

Introducing Digital Circuits.....	8-2
555 Timer Astable Oscillator.....	8-3
Asynchronous Counter	8-4
Demultiplexer.....	8-6
Synchronous BCD Counter Using Discrete Elements	8-8
Worksheets.....	8-11

Section 9: Analog and Digital Combinations

Introducing Mixed Circuits	9-2
Processing Analog Input to Digital and Back.....	9-3
Worksheets.....	9-7

Section 10: Radio Frequency Communication

Introducing Radio Frequency.....	10-2
RF Amplifier with Thermal Noise Source	10-4
Worksheets.....	10-5

Section 11: Waveguides and the Network Analyzer

Introducing Waveguides and the Network Analyzer	11-2
Worksheets.....	11-5

Section 12: Student Evaluation and Pre-Labs

Improving Evaluation Techniques.....	12-3
Simulation Lab Tests	12-4
Pre-laboratory Assignments	12-5
Test Questions.....	12-7
Worksheets.....	12-15

Introduction

Section Contents

This section contains the following:

- “A Note for Instructors About the Purpose of this Book” on page 1-1
- “About Multisim” on page 1-2
- “Relationship Between the Book and Circuit Files” on page 1-3
- “Theory Enhancement” on page 1-4
- “Lab Simulations” on page 1-4
- “Labs on the Bench” on page 1-4
- “As Real as it Gets” on page 1-5
- “Lab for the Instructor” on page 1-5.

A Note for Instructors About the Purpose of this Book

This book is intended to provide a source of proven practical teaching ideas on which an instructor can build. It covers a vast array of subjects, from basic DC circuits to introductory topics in RF Communications. It is a tool by an instructor, for instructors, to help you accomplish more, with fewer resources:

- in less time
- at a lower attrition rate
- with a greater sense of accomplishment for you and your students.

I have designed the many lab activities to meet a large percentage of the requirements of distance learning for students of electronics. Students are free to learn without concern about parts and instrument failures, saving time and budgets. Students can, and I might add, should, be introduced to the “real instrument” when they are already competent in its use.

I have worked with Multisim for years, and love it more with every new update. The program is continually upgraded as the needs and requirements of learning electronics grow. It is incredibly user-friendly. The instruments and components closely match those found in the real world. Some of the instruments such as the Agilent Multimeter, Oscilloscope and Function Generator are actual instruments that exist in physical laboratories. Students who use these instruments in Multisim can immediately transfer their knowledge to the bench. Virtual reality exists in these instruments! Multisim allows National Instruments LabVIEW virtual instruments to be used as well as the exporting of signals to the LabVIEW environment. Importing of real-world LabVIEW signals is also incorporated into Multisim. One example of a LabVIEW virtual instrument can be found in the **SpectrumAnalyzerIntro** lab in Section 10. NI ELVIS breadboarding environments play a strong supportive role throughout the scope of this workbook.

The acquisition of Electronics Workbench by National Instruments adds exciting new dimensions to the education of all electronics students. The flow from the real electronic world to the simulated electronic world and back again is now seamless in its interchangeable enhancement of environments.

Some of Multisim's great strengths are:

- provides a virtual lab for distance learning
- familiarizes students with instrument and component use
- its ease-of-use allows students to concentrate on learning electronics
- more effective teaching of troubleshooting concepts.

If you are teaching electronics, I believe that many of the ideas in this book will help you.

About Multisim and LabVIEW

Multisim has been a leader in the electronics education industry for over 20 years. During that time, many new features, components and instruments have been added to Multisim's database. There are well over 50 leading electronics texts in North America that use Multisim as their software supplement. Its virtual lab environment makes it an ideal laboratory counterpart to the theoretical portion of many distance learning programs.

Research conducted by Thomas M. Hall and others at Northwestern State University in Louisiana examined the effectiveness of simulated laboratory instruction versus the more traditional hardware laboratory experience. The results indicated that there are no significant discrepancies in student achievement between the two groups.

National Instruments has been setting industry standards for 30 years. In 1986, LabVIEW was first launched, revolutionizing the world of engineering. LabVIEW is an acronym for Laboratory Virtual Instrument Engineering Workbench and is a graphical programming language which hosts more than 450 built-in functions for signal processing and analysis. LabVIEW was first available to the Windows environment in 1992.

Because LabVIEW has the flexibility of a programming language combined with built-in tools designed specifically for test, measurement and automation, you can create applications that range from simple temperature monitoring, to sophisticated simulation and control systems. No matter what your project, LabVIEW has the tools necessary. Visit www.ni.com/labview/whatis/ for more information.

National Instruments Educational Laboratory Virtual Instrumentation Suite (NI ELVIS) is a LabVIEW-based design and prototyping environment. NI ELVIS consists of LabVIEW-based virtual instruments, a data acquisition device, a custom-designed benchtop workstation, and a prototyping board. Many of the worksheets contained in this book ask students to set up their circuits on NI ELVIS prototyping boards.

Relationship Between the Book and Circuit Files

All twelve sections of this book have a number of associated circuit files. Schematic diagrams from many of the circuit files are presented along with worksheets that may be copied as handouts. Each worksheet instructs the student to open a file, run the simulation and answer questions. NI ELVIS exercises are included with many of the worksheets. The breadboarding shown in the NI ELVIS experiments reflect the component values and layout contained within the associated .ms10 files. Each NI ELVIS exercise includes additional questions to augment student comprehension of circuit behavior.

References to the user guide that accompanies Multisim are provided for your further investigation. Also, by highlighting a component or instrument, then pressing F1, students and instructors are able to access a help window on the area of interest. The Help button on the Main toolbar is also handy for its indexing properties.

In the Oscilloscope, Bode Plotter, Spectrum Analyzer and Network Analyzer sections, a picture of the instrument itself is provided. It can be copied for handouts or discussed on an overhead projector. A description of how to use the Spectrum Analyzer is found in the Description Box of the file **SpectrumAnalyzerIntro.ms10**. Note that patience is required for a full spectral response when using the Spectrum Analyzer.

Most circuit files have Description Boxes with quizzes or worksheets. You can create your own Description Boxes and use the files for laboratory assignments or tests to be handed in on disk, over the network, or, in the case of distance learning, through e-mail. The student can answer all Description Box questions within the Description Box itself. All of the circuit files are given filenames that clearly identify their nature with the exception of those names which you may want to hide from the student.

The book covers an array of topics from basic DC analysis to RF communications. The very essential topic of troubleshooting is covered in depth in Section 5. You are advised how to set passwords on the faults in this section so that students are denied access to them.

Section 11 introduces the Network Analyzer but also shows the student different features of the simulated instrument. More information on the Network Analyzer may be obtained in the user guide included with Multisim and in my lab manual *RF Communications with Multisim*.

Section 12 deals with the unique evaluation capabilities of Multisim. You are shown simple methods of creating and marking multiple tests, as well as strategies to increase the fairness of assigning part marks. The Question Link feature is a user-friendly testing feature that lets you set up true/false and multiple choice questions with ease. Students can complete the answers in the circuit files and submit them to you via e-mail. All of the test questions in Section 12 along with several other files throughout the workbook contain true/false and/or multiple choice questions. Students are required to breadboard their circuits within Multisim in many of the files. Breadboarding instructions can be found in the Description Boxes of each file.

All strategies, procedures and circuit files may be adapted to your individual requirements.

Theory Enhancement

The material studied here is useful in either a traditional or virtual classroom. Basic theory will teach associated calculations and the basis for circuit behavior predictions.

Printouts of circuits, simulations, Description Boxes and instruments can be used. Opening an instrument window, then pressing ALT-PRINT SCREEN will copy the instrument into the clipboard. The copy can then be pasted into a word processor, PowerPoint™, or other software.

Lab Simulations

This book references numerous circuit files that may be individually simulated. Traditional lab questions and quizzes are provided with these circuits. Students run the simulations and compare the simulated results with that of the theoretical calculations and are encouraged to think about any discrepancies. Component values may be changed, sources may be increased or decreased, potentiometers and variable capacitor values changed and entire circuits altered. The results are instantly displayed when the simulation is run.

Students are not confined to theoretical results. Tolerances may be set to emulate real component behavior. You will find that Multisim provides a highly interactive environment where unlimited quantities of parts and multiple instruments are available to overcome the time-consuming restraints found in traditional laboratories.

Many new components and features have been added to the latest versions of Multisim. These include several transducers, a 3-phase source, a voltage controlled resistor, several Agilent measuring instruments, an Oscilloscope, an IV meter, multi Dynamic Measurement Probes, Description Boxes that can respond to the simulations, a Breadboarding window and features such as the Spreadsheet View, and the Off Page Connector. The ability to incorporate sound and video in the Description Box is also available. New transistor circuit wizard labs have been incorporated into Section 4. The transistor circuit wizard feature has the potential to save you time and allow students to study different parameters in order to augment theory and labs for an even more substantive understanding of transistors. The Question Link feature as discussed in the Introduction adds user-friendly flexibility in the generation of tests. A clamp-on current probe has been incorporated into several experiments.

Labs on the Bench

Students who have been introduced to electronic instruments in Multisim find the transition to bench equipment straightforward. They have earned the right to use the real thing. They are not learning the theory behind the topic areas; they already know it. They are able to concentrate on using the equipment, purchasing and identifying components and finding out what can go wrong in a real lab environment. They learn well, because they are not being overloaded. What is the overall outcome for you? In my experience, it means more students to be proud of on graduation day.

As Real as it Gets

For a small demonstration of 3-D components, open **AsRealAsItGets.ms10** in the Section 1 folder and run the simulation. Remember that as with a real Function Generator, the Agilent Function Generator and the Agilent Oscilloscope and Tektronix Oscilloscope must be turned on before they will operate.

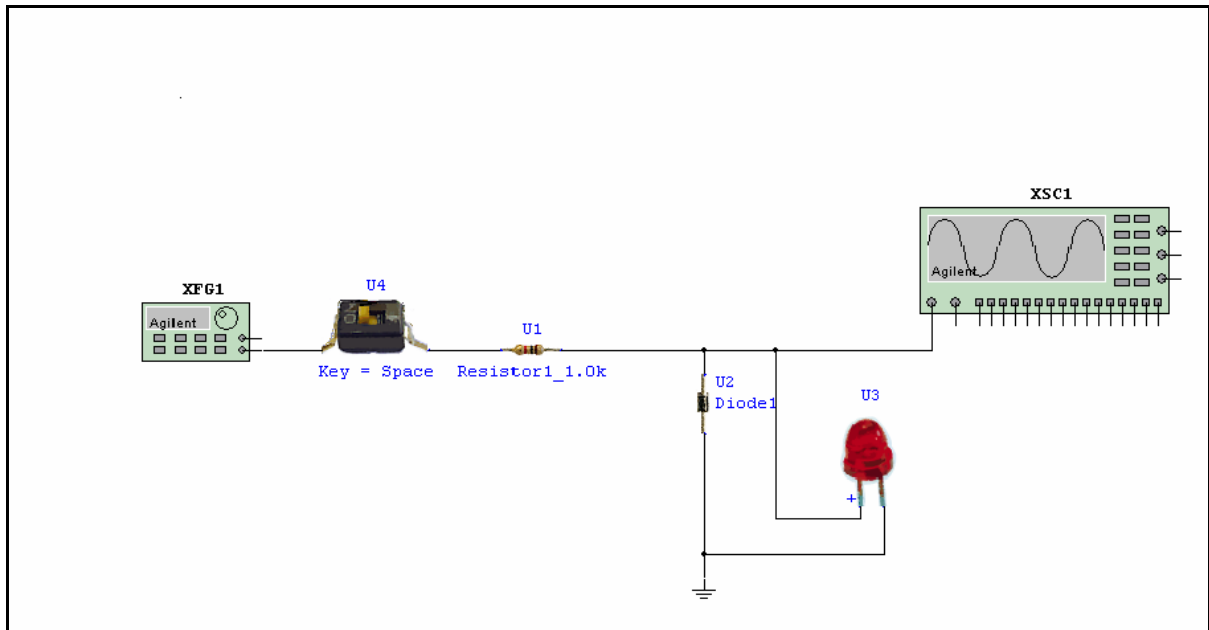

AsRealAsItGets.ms10

Lab for the Instructor

Open the file **ToTheInstructor.ms10** in order to view or listen to instructions on how to customize student workspace so that one or more toolbars are made unavailable for student use.

Section 1: DC and Thevenin's Theorem

Section Contents

This section contains the following:

- “Introduction to Section 1” on page 1-9
- “Reinforcing Concepts of Basic Circuit Behavior” on page 1-10
- “Agilent Multimeter” on page 1-12
- “Voltage Controlled Current Source and Three Phase Source” on page 1-13
- “Using a Variable Resistor and a Switch to Change Values” on page 1-14
- “Voltage Controlled Resistor” on page 1-16
- “Rated Components” on page 1-17
- “Thevenin's Theorem” on page 1-18.

Worksheets in this Section

The following Worksheets start on page 1 of Worksheet 1-1: Resistor Color Codes:

- “Worksheet 1-1: Resistor Color Codes”
- “Worksheet 1-2: Basic Circuits”
- “Worksheet 1-3: Basic Circuits”
- “Worksheet 1-4: Variable Resistor Activity”.

Circuits for this Section

The following is a list of the file names of circuits used in this section and a brief description of each.

File (.ms10)	Description
Agilent Multimeter	An example of an actual instrument that is used in many laboratory facilities.
Ohm	An example of series-parallel circuit behavior.
RatedComponents	Two examples of Multisim's rated components in two separate circuits.
TwoOtherSources	Circuit A is the same as Ohm.ms10 except it has a Voltage Controlled Current Source. Circuit B is a Three Phase Source connected to a Four Input Oscilloscope.
Ohms2	Using a variable resistor and a switch to change values in a circuit.
Resistor Color Codes	Using Multisim's 3-D components to simulate a color coding lab.
Thevenin1	The Thevenin method of circuit analysis.
Thevenin1A-Thevenin1C	The three steps, with equivalent circuits, for Thevenin analysis. (Suitable for making overheads or through use with PowerPoint).

Thevenin1TS	A faulted version of Thevenin1 .
Thevenin2	A circuit with two sources for Thevenin analysis.
Thevenin2_TS	A faulted version of Thevenin2 .
VoltageControlledResistor	An example of a voltage controlled resistor setup and behavior.

Introduction to Section 1

Multisim encourages the use of multiple instruments. This means that the number of operating characteristics that may be monitored at the same time is unlimited. Students are given the unique opportunity of observing the effects of changing a given component in every area of interest around the schematic. This feature provides instant results and provides a perfect avenue for the “What would happen if..?” scenario of teaching electronics.

You can ask students to make predictions about circuit behavior and observe instantaneous results. Students are encouraged to become interactive and to think in a manner that allows a “pulling together” of basic concepts. This reduces attrition in courses delivered both in classrooms and by long distance learning.

The enhanced ability to address the “What would happen if ?” inquiry is invaluable when attempting to reinforce understanding of basic circuit behavior:

- For distance education
- In lecture demonstrations
- In software laboratory settings.

Benefits are also realized in distance education where students are able to familiarize themselves with simulated instruments, which closely match that of their traditional laboratory counterparts. This vastly reduces the hands-on instrument and component time necessary to complete course curriculum.

Section 1 provides worksheets, which further encourage student interaction between themselves and their own learning process. To introduce troubleshooting procedures at an early stage, two files are included that contain faults. Voltage and resistance values may be changed by double-clicking on the component of interest. Multi Dynamic Measurement Probes may be used to measure voltages around the circuit quickly and efficiently. In order to solve the circuit, the student selects **Simulate/Run** or clicks on the switch to start the simulation.

Reinforcing Concepts of Basic Circuit Behavior

Goal

To reinforce concepts of basic circuit behavior in series-parallel circuits.

Prerequisites

It is assumed that the student knows the units of measurement for voltage and current and is able to use Multisim's meters and voltage probes.

Comments

Tolerances may be set for each component in order to simulate a close facsimile of a real lab environment. This is accomplished by double-clicking on the component of interest.

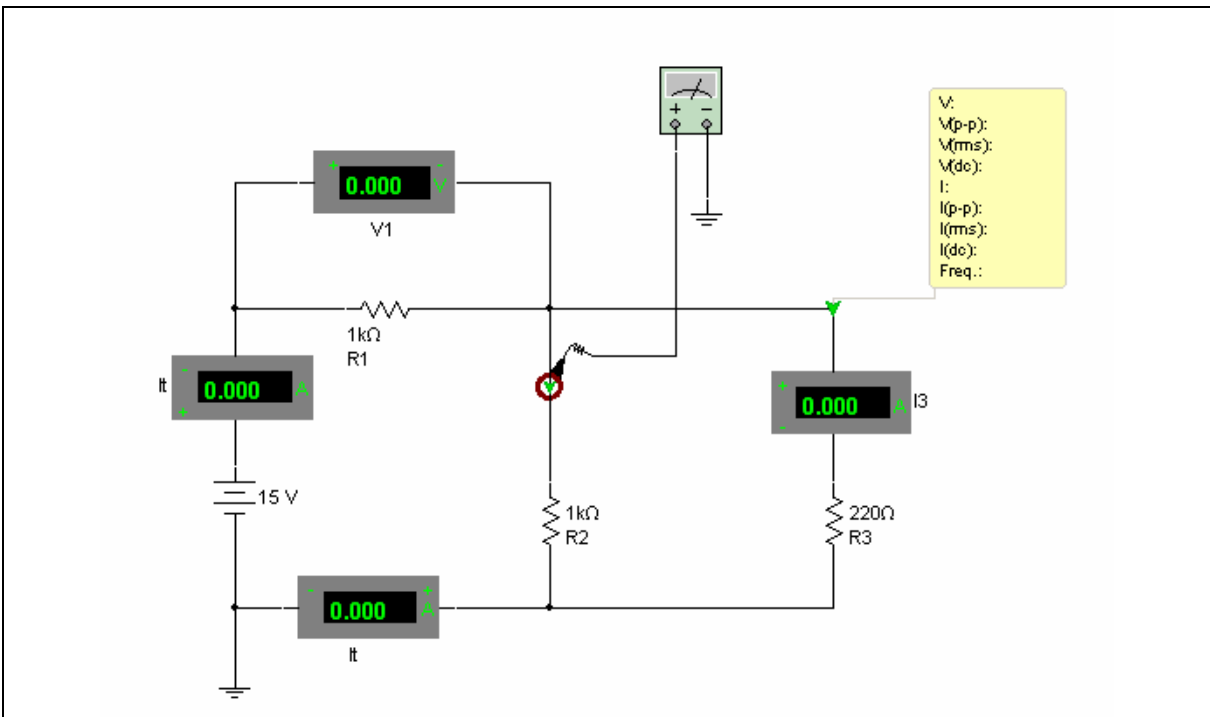

Figure 1-1: Ohm.ms10

Procedure

1. Open file **Ohm.ms10**.
2. Calculate values for all voltages and currents in the circuit. Record these values on the worksheet.
3. Use the power switch or select **Simulate/Run** from the menu to solve the circuit and check the measured values against the calculated values.
4. Select a new value for any resistor.
5. Predict the *direction of change* of each voltage and current in the circuit (increased value, decreased value or no change) and record your prediction on the worksheet.
6. Calculate the new values of current and voltage and record them.
7. Use the power switch or select **Simulate/Run** from the menu to solve the circuit. *Compare* the predicted and simulated values.

The current probe acts like a clamp-on current probe that converts the current flowing through a wire to a voltage at the output of the probe. In this circuit, the output of the probe has been connected to the multimeter. To use, set the multimeter to V, then read the 1V/mA output in Amperes.

Relevant Worksheets

“Worksheet 1-2: Basic Circuits”.

Agilent Multimeter

Goal

To familiarize the student with Multisim's "real" simulated Multimeter. The lab will guide the student through the basic use of a real meter, including the continuity feature which is used in a troubleshooting example.

Comments

The Agilent Multimeter can be found on the lower right hand side of the Instruments toolbar.

Procedure

1. Open **AgilentMultimeter.ms10**.

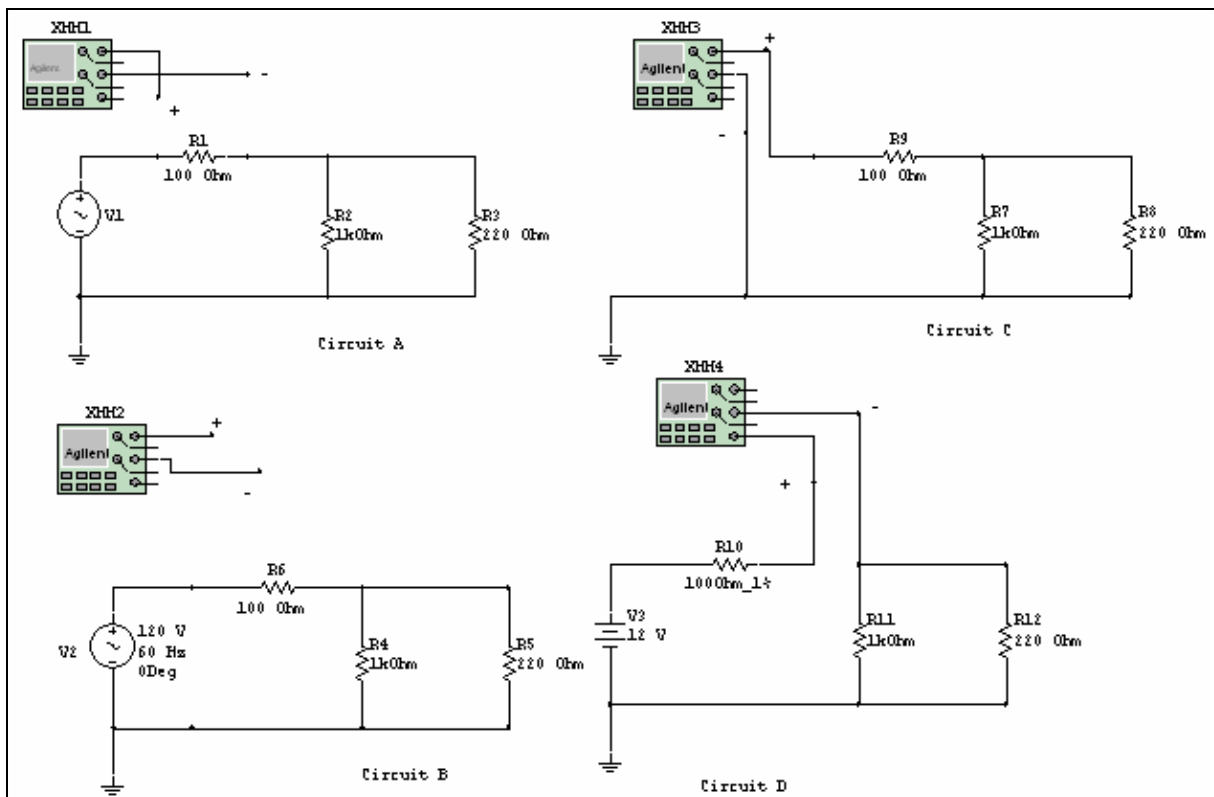

Figure 1-2: AgilentMultimeter.ms10

2. Open the Circuit Description Box.
3. Run the simulation by clicking on the switch or selecting **Simulate/Run**.

Voltage Controlled Current Source and Three Phase Source

Goal

To familiarize the student with Multisim's Voltage Controlled Current Source and Three Phase Source.

Comments

TwoOtherSources.ms10 Circuit A contains the same circuit as **Ohm.ms10** except it makes use of a Voltage Controlled Current supply. The output current I_2 is dependent on the voltage applied at the input terminals. The two are related by the ratio of the output current to the input voltage, its Transconductance. This ratio is set to 1×10^{-3} Mhos. Voltage Controlled Voltage Sources, Current Controlled Voltage Sources and Current Controlled Current Sources are also available in the database. Circuit B is an example of a Three Phase Source using Multisim's Four Channel Oscilloscope. The Three Phase Source is also available in the database.

Procedure

1. Open **TwoOtherSources.ms10**. Observe Circuit A.

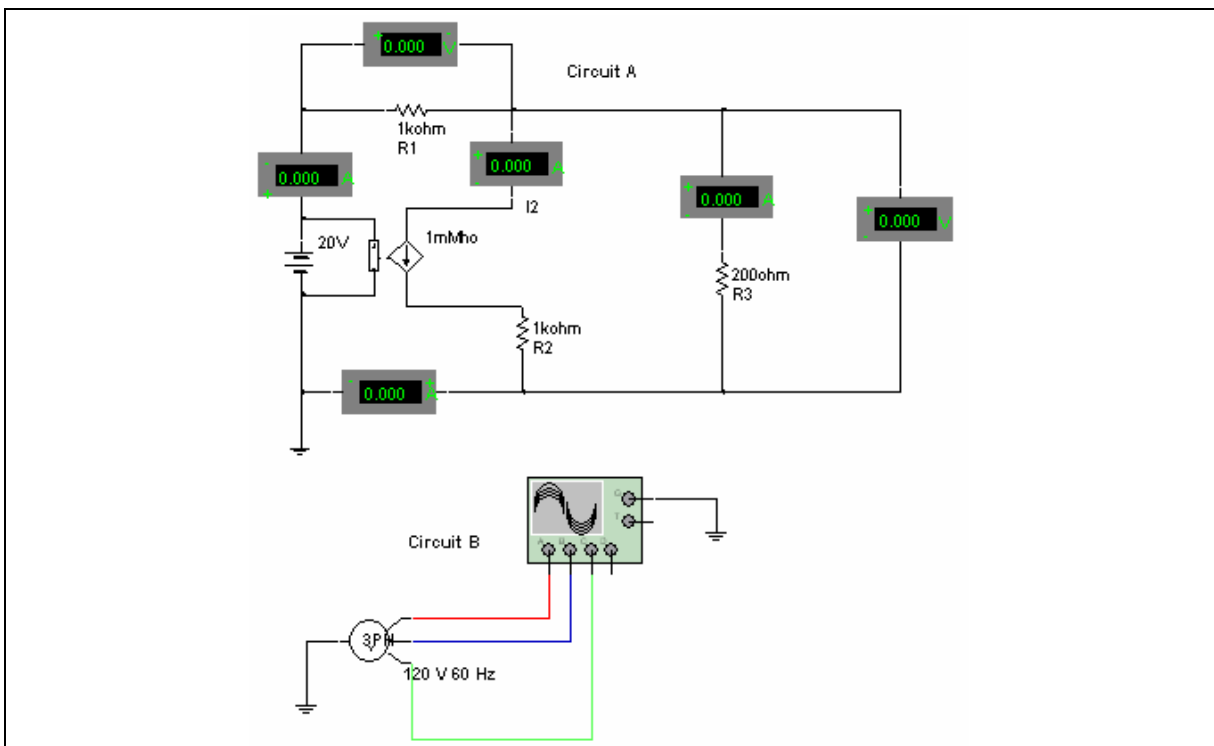

Figure 1-3: TwoOtherSources.ms10

2. Run the simulation by clicking on the switch or selecting **Simulate/Run**.
3. Compare the values displayed on the indicators with your results from **Ohm.ms10**.
4. Observe Circuit B and follow the instructions in the Circuit Description Box.

Using a Variable Resistor and a Switch to Change Values

Goal

To observe the behavior of a series-parallel circuit.

Comments

Tolerances may be set for each component so that the simulations will more closely resemble that of a real lab environment. Tolerances are set by double-clicking on the component of interest.

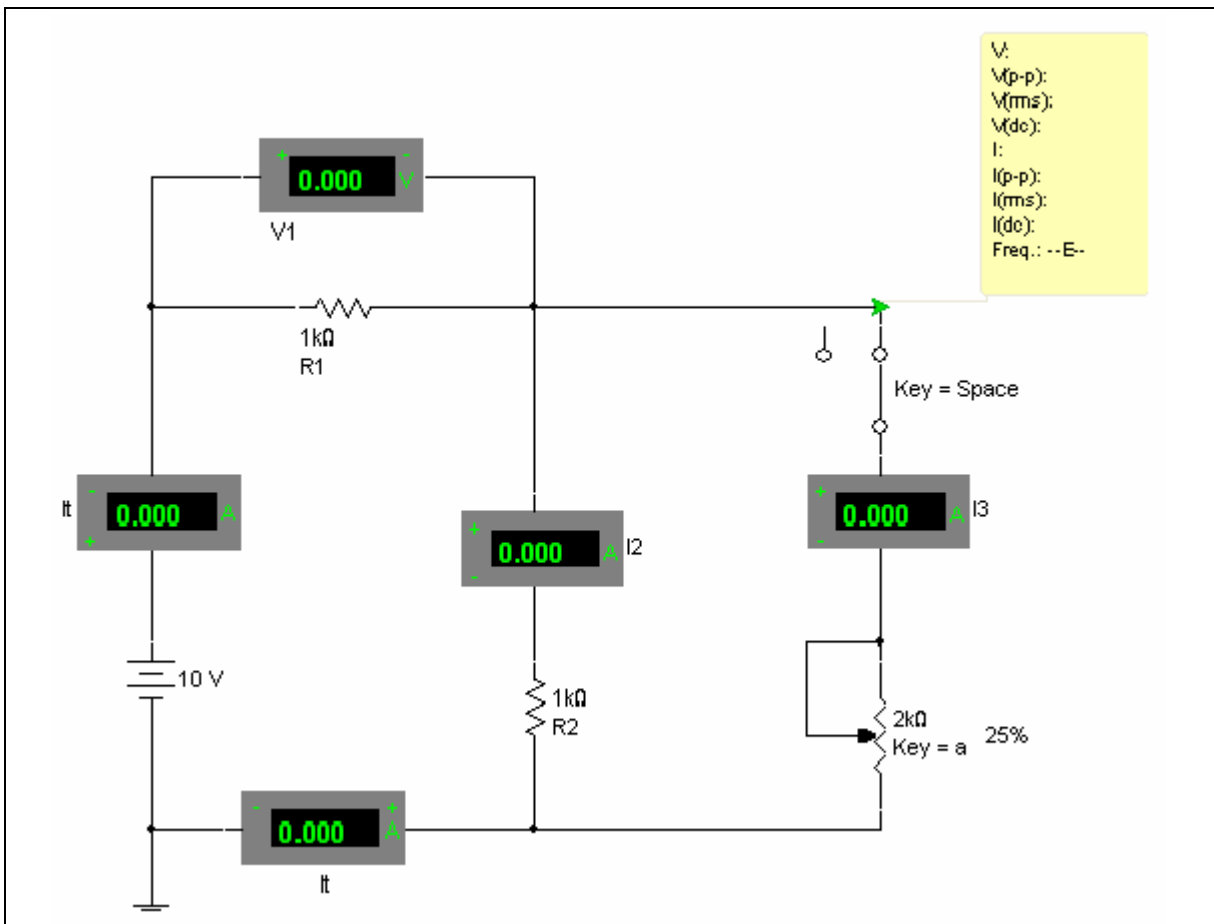

Figure 1-4: Ohms2.ms10

Procedure

1. Open circuit file **Ohms2.ms10**.
2. Close the switch. Set the potentiometer to 25%. Solve the circuit and calculate the value of R3.
3. Change the value of R3 by pressing A or SHIFT-A until it reads 60%. You can also hover the cursor over the potentiometer and drag the slider that appears. The potentiometer may be adjusted during the simulation.
4. Predict the *direction of change* of each voltage and current result in the circuit.
5. Calculate the new value of R3 using voltage and current measurements.
6. Solve the circuit and compare the predicted and simulated values.
7. Open the switch. Predict the direction of change of each voltage and current in the circuit.
8. Solve the circuit. Run the simulation and compare your results.

Relevant Worksheets

“Worksheet 1-3: Variable Resistor Activity”.

Voltage Controlled Resistor

Goal

To familiarize the student with Multisim's Voltage Controlled Resistor (VCR). The VCR is used in combination with the various other resistors in the circuit in order to create a model of an active device. This lab concentrates on how the VCR functions within a circuit.

Comments

The voltmeter and ammeter can be found in the Indicators component bin.

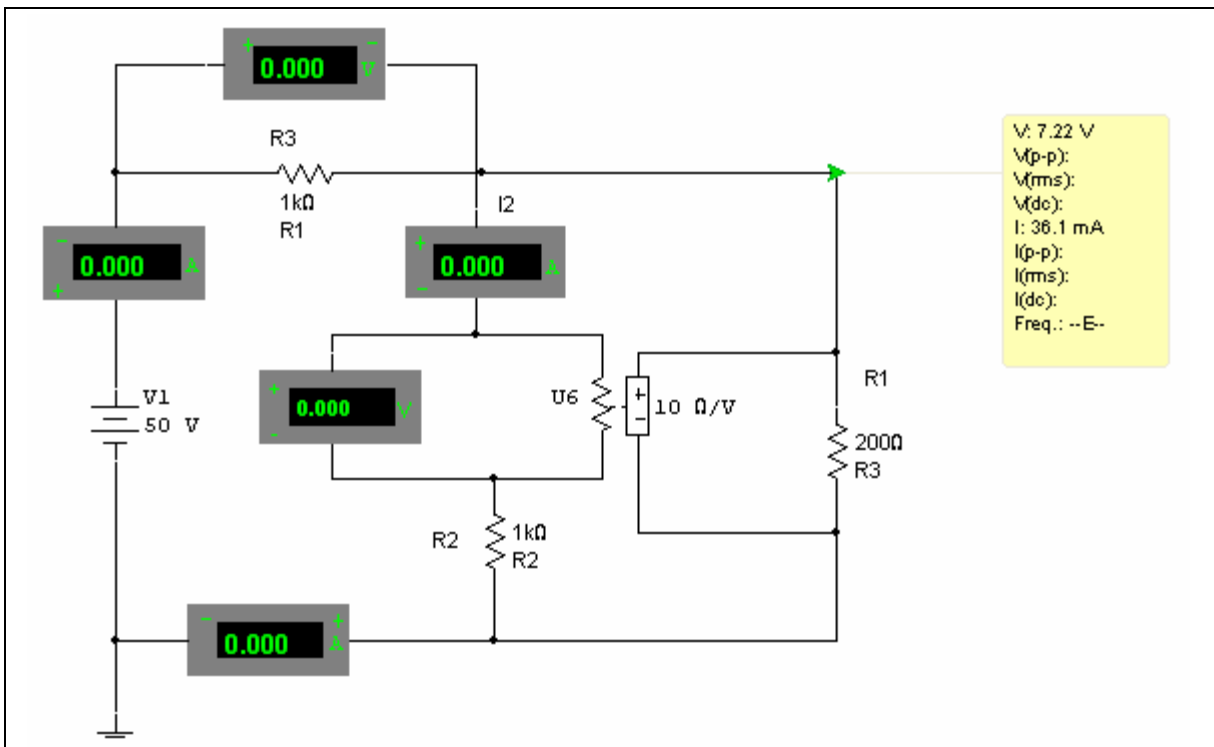

Figure 1-5: VoltageControlledResistor.ms10

Procedure

1. Open **VoltageControlledResistor.ms10**.
2. Open the Description Box.
3. Run the simulation by clicking on the switch or selecting **Simulate/Run**.

Rated Components

Goal

To reinforce the importance of rating components used in real laboratory situations.

Comments

A similar hands-on lab in a non-simulated environment is possible, but is not generally attempted because of the inherent danger.

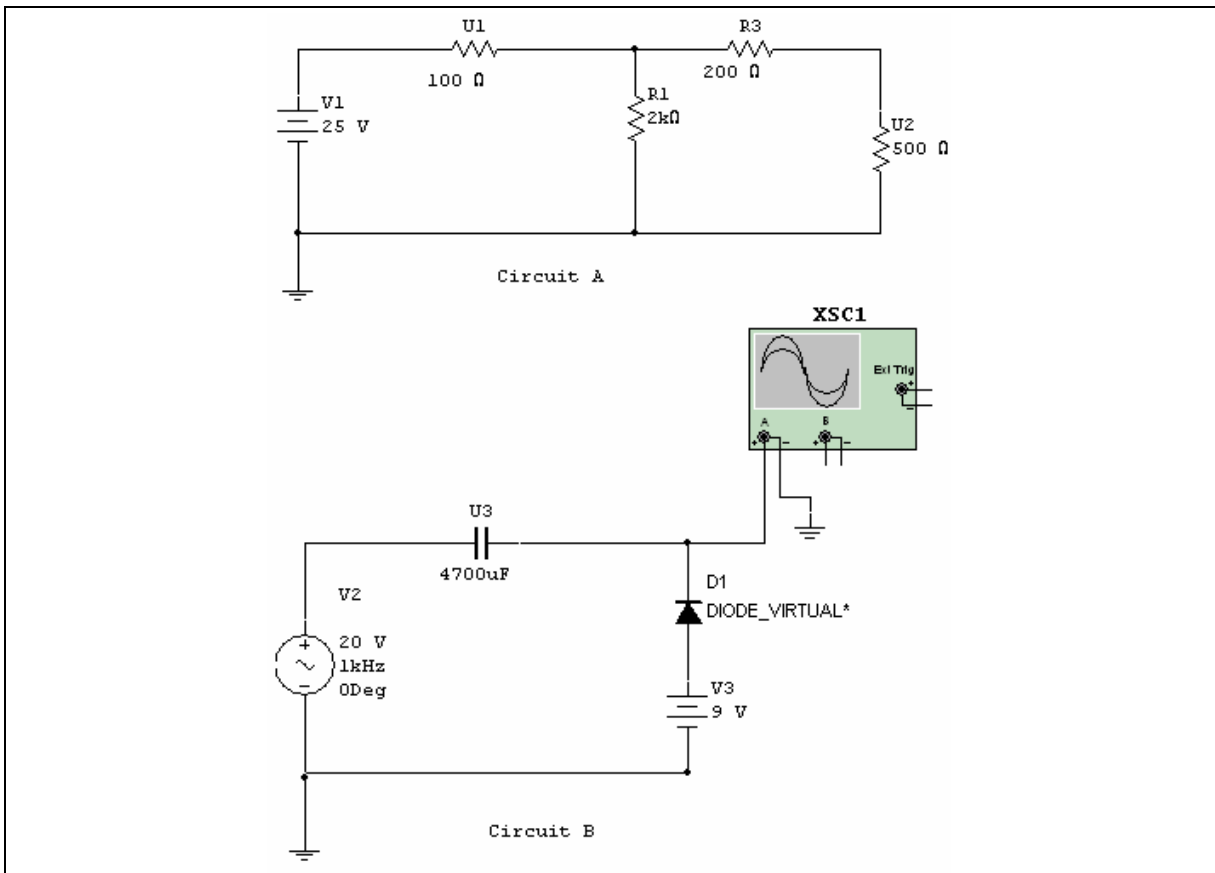

Figure 1-6: RatedComponents.ms10

Procedure

1. Open **RatedComponents.ms10**.
2. Open the Description Box.
3. Run the simulation by clicking on the switch or selecting **Simulate/Run**.

Thevenin's Theorem

The remaining files in this section provide an introduction to Thevenin's Theorem:

- Circuit file **Thevenin1.ms10** includes description boxes that provide student worksheets that assist in the step-by-step solution to a circuit using this network analysis method
- Circuits **Thevenin1A** through **Thevenin1C** illustrate the individual steps to a Thevenin solution
- Circuit file **Thevenin2** provides a more complex circuit with two sources for advanced practice.

Note The individual step files for circuits **Thevenin1.ms10** and circuits **Thevenin1A** through **Thevenin1C** may be printed for pre-lab preparation, used to produce overheads or as a classroom demonstration through PowerPoint.

Goal

To illustrate and practice the steps involved in using Thevenin's Theorem to analyze a complex circuit through simulation.

Prerequisites

It is assumed that students know how to solve series-parallel circuits.

You need the following circuit files:

- **Thevenin1.ms10**
- **Thevenin1A.ms10** through **Thevenin1C.ms10**
- **Thevenin2.ms10**.

Comments

Calculating an equivalent circuit can be a confusing process for students. The Thevenin method is straightforward because the detailed analytical steps stated in the majority of texts may be directly followed when solving problems.

Procedure

1. Open circuit file **Thevenin1.ms10**. A sample student worksheet is included in the Description Box. For student assignments or quizzes, you can change values or substitute circuits from the course text.

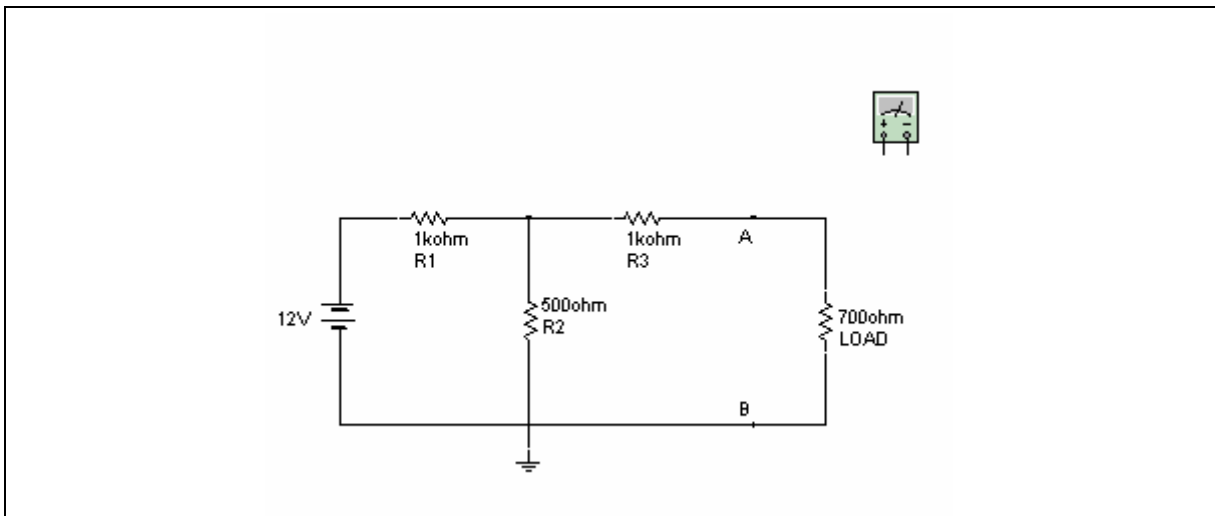

Figure 1-7: Thevenin1.ms10

2. Measure the original load voltage and current.
3. Remove the load resistor and move it elsewhere on the workspace, for example, below the original circuit. (See file **Thevenin1A.ms10**).

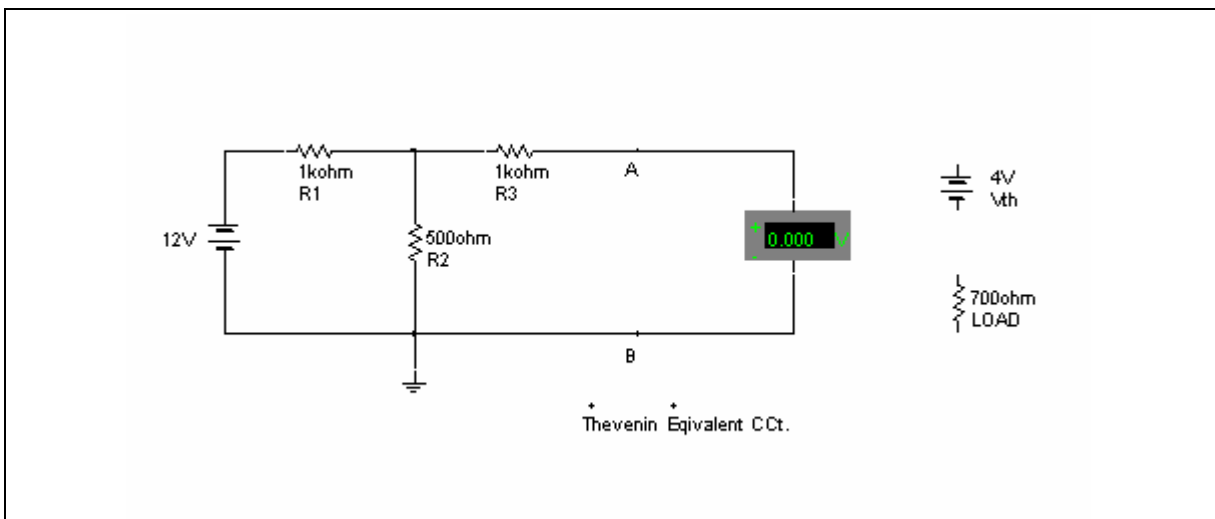

Figure 1-8: Thevenin1A.ms10

4. Have the students measure the open circuit voltage with a meter and create a battery with that value.
5. Next, have them measure the open circuit resistance with all the circuit batteries removed and replaced with short circuits. Create a resistor with this value. (See file **Thevenin1B.ms10**).

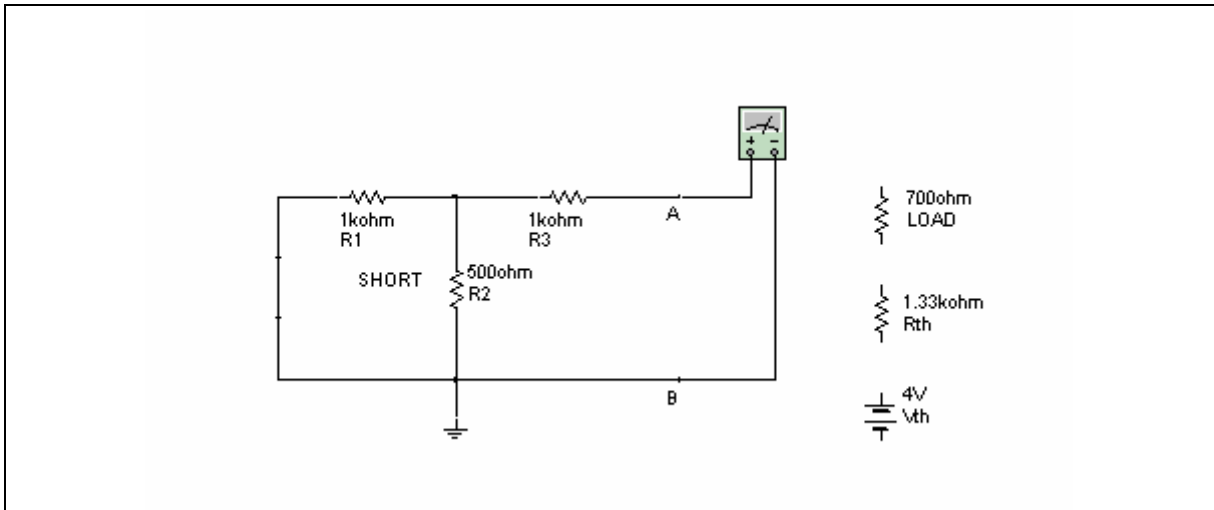

Figure 1-9: Thevenin1B.ms10

6. Connect V_{th} , R_{th} and the original load resistor as a separate, *simpler* circuit. This is the *Thevenin equivalent* circuit, which will behave exactly as the original circuit does.

Notes: The combination of one battery and one resistor, along with the load resistor, now replaces the complete circuit. (See file **Thevenin1C.ms10**).

The process is justified when you can show that the original circuit and the new Thevenin circuit produce the same voltage across, and current through, the load resistor. You can demonstrate the usefulness of this theorem by changing the value of the load resistor, both in the original circuit and in the Thevenin equivalent circuit. Students will see that the results are the same, proving that the Thevenin voltage and resistance are independent of the load resistance.

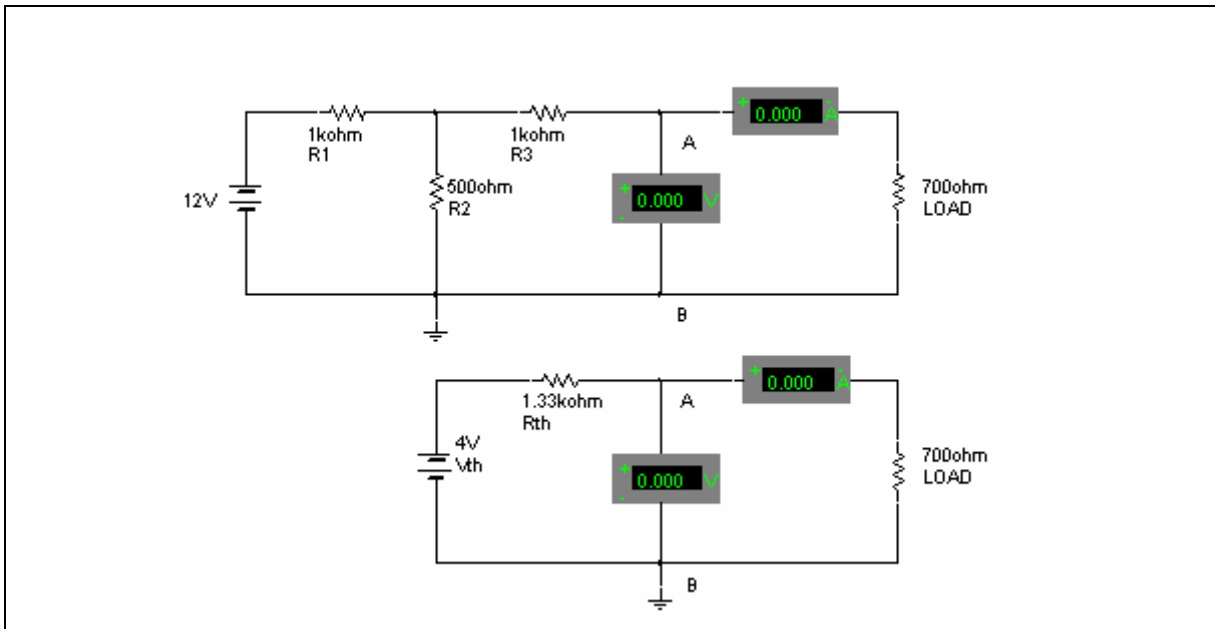

Figure 1-10: Thevenin1C.ms10

Extension Ideas

Multisim may be used for long distance learning, classroom demonstrations using PowerPoint or even printouts used on an overhead projector. The use of computer labs enables a number of students to step through many examples while encouraging basic theory augmentation.

Once students understand the basic concept of Thevenin's Theorem, they can apply it to a large variety of circuits obtained from any text on DC and AC theory as well as to active devices such as transistors and FETs.

Circuit **Thevenin2.ms10** provides an example of a more complex circuit that includes two sources. Students can analyze it using the same worksheets as for **Thevenin1**. Circuits **Thevenin1** through **Thevenin1C** include the original circuit and step-by-step procedure using Thevenin's Theorem.

Circuits can be taken from examples in any text and substituted for the samples provided.

Additional Challenge

Two circuit files contain faults and are denoted with the letters “TS”. As an instructor, you might observe these faults by de-selecting the **Hide component faults** checkbox found under **Options/Circuit Restrictions/General tab**. If you provide a password, you can prohibit student access before distributing the files.

Multisim provides an ideal troubleshooting environment for consolidating and reinforcing basic theory. Description Boxes are used to guide the student through the troubleshooting process. Promoting problem-solving logic is further encouraged in the troubleshooting section of this workbook. The troubleshooting circuits pertaining to this section are **Thevenin1TS.ms10** and **Thevenin2TS.ms10**.

References

Topic	Reference
Multimeter	Multisim User Guide: Ch. 8 “Instruments”
Ammeter	Multisim User Guide: Ch. 8 “Instruments”
Voltmeter	Multisim User Guide: Ch. 8 “Instruments”

Worksheet 1-1: Resistor Color Codes









Name: _____ ID Number: _____ Class: _____

Starting Point

Open the file **ResistorColorCodes.ms10**.

Questions

State the value of the following resistors based on their color coding.

- | | | <u>Value</u> |
|----|---|-----------------------------|
| 1. |  | yellow, violet, brown _____ |
| 2. |  | yellow, violet, red _____ |
| 3. |  | red, red, red _____ |
| 4. |  | brown, black, red _____ |
| 5. |  | brown, black, orange _____ |
| 6. |  | brown, black, black _____ |
| 7. |  | orange, white, red _____ |
| 8. |  | green, blue, yellow _____ |

9.  grey, red, orange _____

10.  white, brown, blue _____

11.  brown, black, blue _____

Worksheet 1-2: Basic Circuits

Name: _____ ID Number: _____ Class: _____

Starting Point

Open the file **Ohm.ms10**.

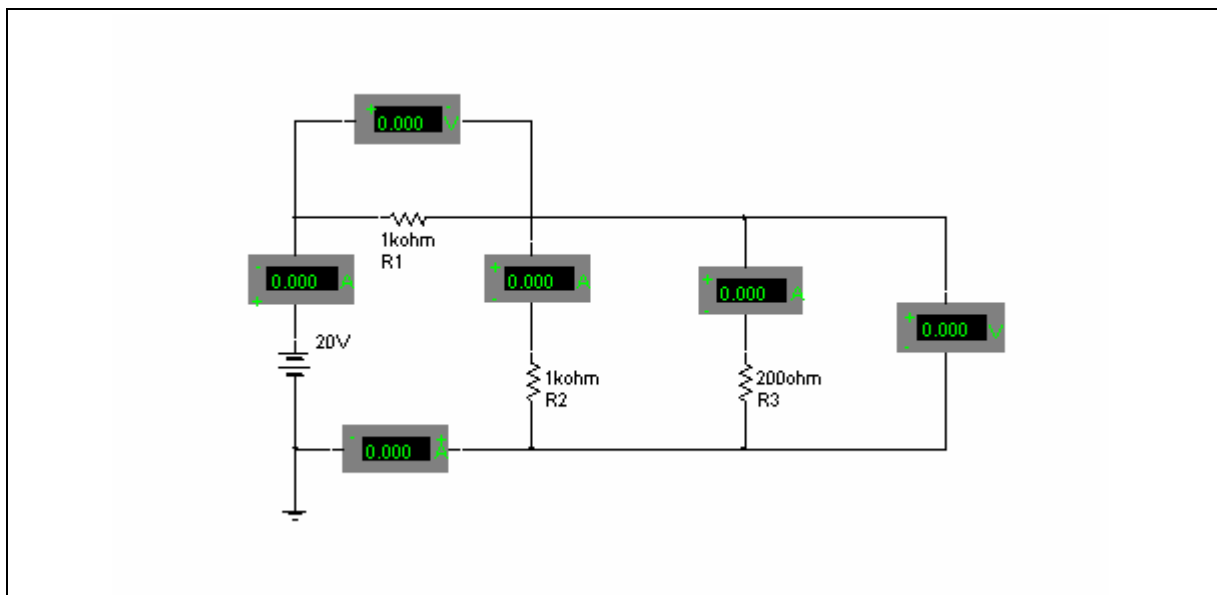

Questions

1. Complete the following table for the circuit.

Quantity	Calculated	Measured	% Difference
I_t			
V_1			
I_2			
I_3			
I_3			
$V_{2/3}$			

2. Predicting general behavior of a circuit:

If _____ is changed to _____, the predicted direction of change is: _____
(increase, decrease, stay the same).

NI ELVIS Exercise

Starting Point

1. Open the file **Ohm.ms10** in Multisim.
2. Create the circuit **Ohm.ms10** on your NI ELVIS breadboard, as shown in the figure below.

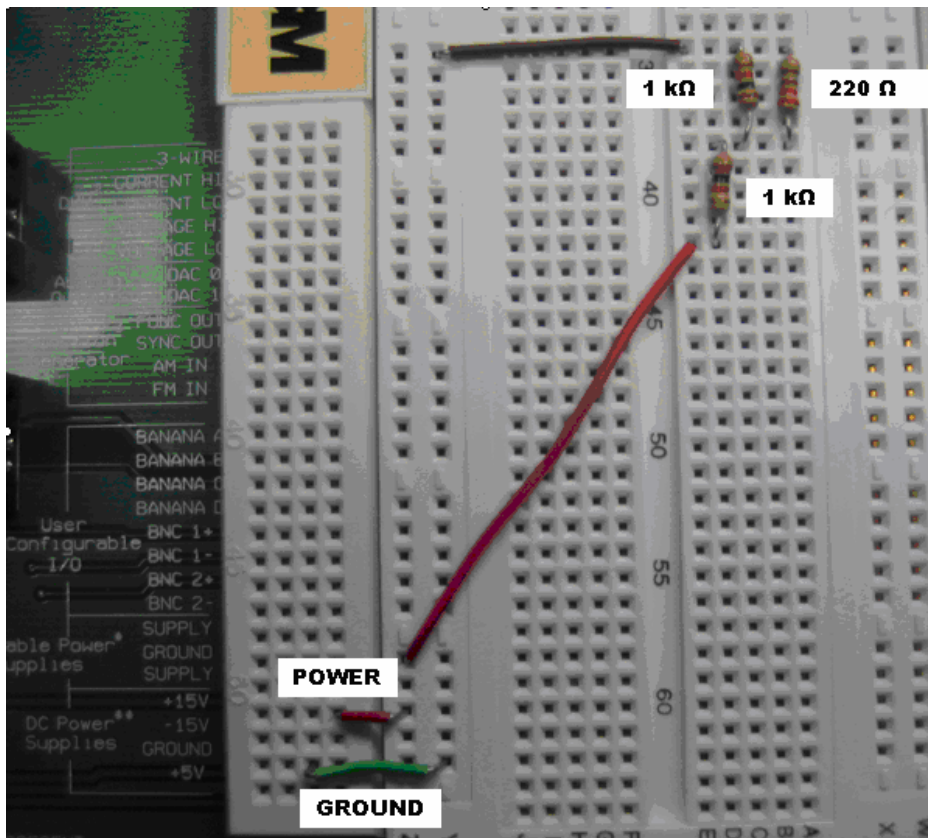

Questions

1. Complete the following table for the circuit. Show calculations.

Quantity	Calculated	Simulated	Measured	% Difference
I_1				
V_1				
I_2				
I_3				

2. Do these observed values match your calculation and simulation? If not, why?

3. Predict the general behavior of the circuit (increase, decrease, or stay the same):

- a) If R_1 is changed to $100\ \Omega$, I_2 will _____.
- b) If R_1 is changed to $2\ \text{k}\Omega$, I_t will _____.
- c) If R_2 is changed to $2\ \text{k}\Omega$, I_2 will _____.
- d) If R_2 is changed to $100\ \Omega$, V_1 will _____.
- e) If R_2 is changed to $100\ \Omega$, I_3 will _____.
- f) If R_3 is changed to $100\ \Omega$, I_3 will _____.

Worksheet 1-3: Basic Circuits

Name: _____ ID Number: _____ Class: _____

Starting Point

Open the file **Ohms2.ms10**.

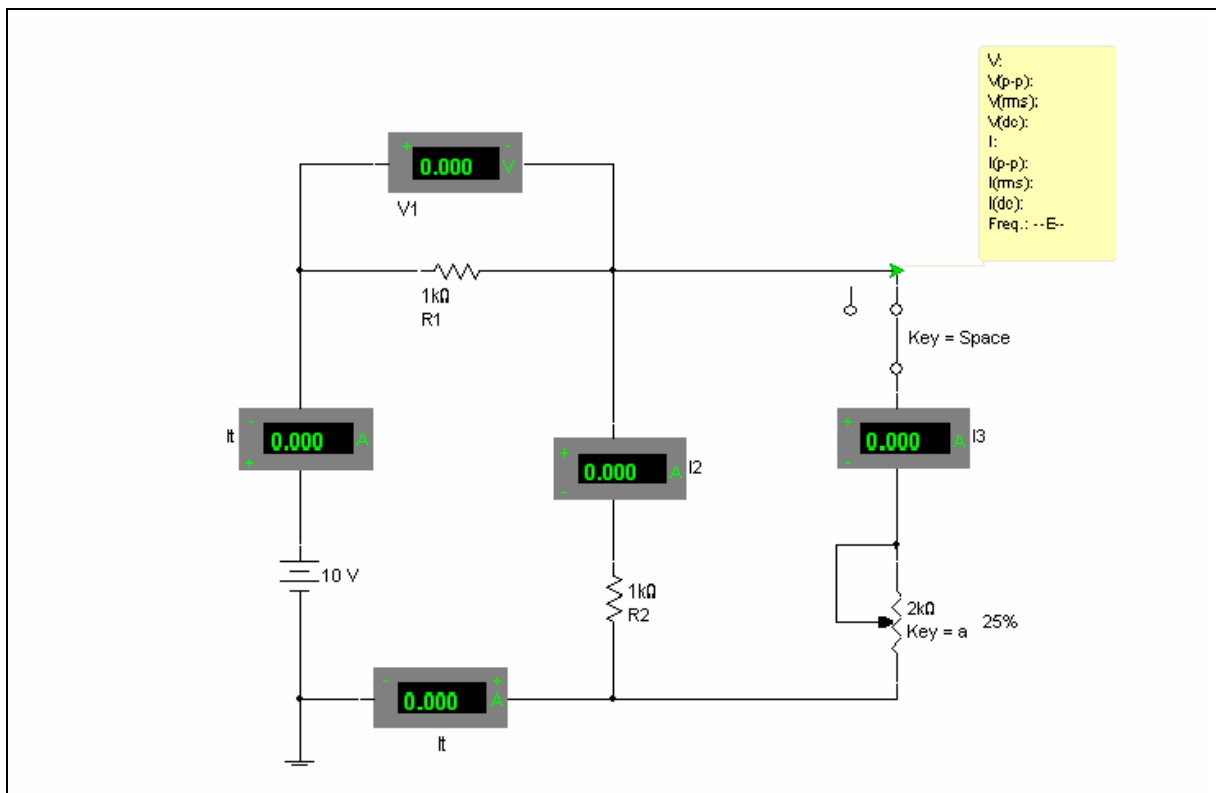

Questions

- Complete the following table for the circuit.

Quantity	Direction of Change	Calculated	Measured	% Difference
I_t				
V_1				
I_2				
I_3				
I_3				
R_3				

NI ELVIS Exercise

Starting Point

- Open the file **Ohms2.ms10** in Multisim.
- Create the circuit **Ohms2.ms10** on your NI ELVIS breadboard, as shown in the figure below.

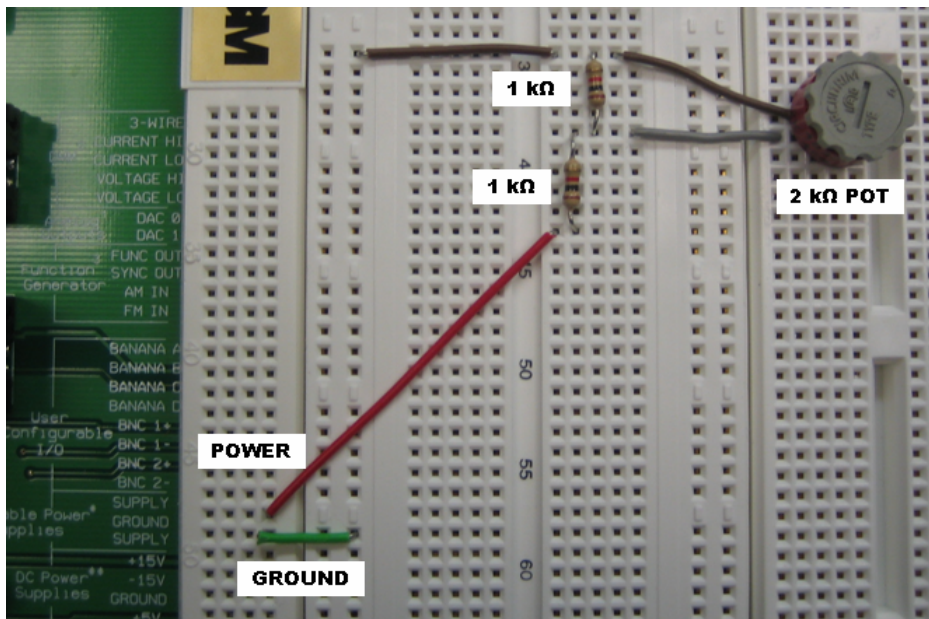

Questions

1. Complete the following table for the circuit where the potentiometer is set to 25%. Show calculations.

Quantity	Calculated	Simulated	Measured	% Difference
R_3				
I_t				
V_1				
I_2				
I_3				

2. Predict the direction of change of each voltage and current result in the circuit if the potentiometer is increased to 60%.

Quantity	Direction of Change
I_t	
V_1	
I_2	
I_3	

3. Complete the following table for the circuit where the potentiometer is set to 60%.

Quantity	Calculated	Simulated	Measured	% Difference
R_3				
I_t				
V_1				
I_2				
I_3				

4. Change the potentiometer on the simulation to 73%. Calculate the new value of R_3 using the voltage and current measurements. Show calculations.

$$R_3 = \text{_____ ohms}$$

5. Predict the direction of change of each voltage and current result in the circuit if the switch were opened.

Quantity	Direction of Change
-----------------	----------------------------

I_1

V_1

I_2

I_3

6. Complete the following table for the circuit where switch is opened.

Quantity	Calculated	Simulated	Measured	% Difference
-----------------	-------------------	------------------	-----------------	---------------------

I_1

V_1

I_2

I_3

Worksheet 1-4: Variable Resistor Activity

Name: _____ ID Number: _____ Class: _____

Starting Point

Open circuit file **Ohms2.ms10**.

Questions

1. Close the switch.
2. Set the potentiometer to 25%.
3. Solve the circuit and calculate the value of R3. Show calculations.

R3 = _____ ohms

4. Change the value of R3 by pressing either A or SHIFT-A until it reads 60% (the potentiometer may be adjusted during the simulation). You can also hover the cursor over the potentiometer and drag the slider that appears. Predict the *direction of change* of each voltage and current result in the circuit. Show calculations.
5. Calculate the new value of R3 using voltage and current measurements. Show calculations.

R3 = _____ ohms

Section 2: Oscilloscope and Filters Introduced with the Bode Plotter

Section Contents

This section contains the following:

- “Introducing the Oscilloscope” on page 2-3
- “Introducing the Bode Plotter” on page 2-5
- “The Low-Pass Filter” on page 2-7
- “Series RLC Resonant Circuit as a Filter” on page 2-9
- “Simultaneous Comparison: Active and Passive Filters” on page 2-11
- “Agilent Oscilloscope” on page 2-12
- “Wizard” on page 2-14.

Worksheets in this Section

The following worksheets start on page 1 of Worksheet 2-1: The Oscilloscope 1:

- “Worksheet 2-1: The Oscilloscope 1”
- “Worksheet 2-2: The Oscilloscope 2”
- “Worksheet 2-3: Measuring Amplitude and Phase Shift with the Scope”
- “Worksheet 2-4: The Low-Pass Filter”
- “Worksheet 2-5: Series Resonant Circuit as a Filter”.

Circuits for this Section

The following is a list of the file names of circuits used in this section and a brief description of each.

File (.ms10)	Description
AgilentOscilloscope	Introduces an actual instrument that is used in many laboratory facilities.
Filter 1	Introduces the Bode Plotter. Setting scales and using the marker for accurate measurements on an RC low-pass filter with both linear and logarithmic scales. Decibel notation and phase measurements.
Filter 1TS	A faulted version of Filter1.ms10 .
Filter2	A side-by-side comparison of loaded and unloaded performance of a passive RC filter and an active filter using an op-amp.
Filter3	Using the Bode Plotter to investigate a passive band-pass filter.

File (.ms10)	Description
Filter4	Using the Bode Plotter to investigate a passive notch filter.
Filter4TS	A faulted version of Filter4.ms10 .
Scope1	Introduces the scope. Measuring amplitude and time and calculating frequency.
Scope2	Scope adjustment technique with a signal where the scope is set to its initial value.
Scope3	Phase and amplitude measurements with the Oscilloscope.
Wizard1	Introduces the use of the Filter Wizard.

Multisim allows students to learn about the scope's settings and how they relate to circuit analysis in an environment which is harmless to the instrument and the components.

For distance learning, students often using their own computers are able to learn this simulation program, taking as much time as they need before being introduced to the real thing. In a more traditional classroom environment, you may choose to require students to demonstrate the proper use of the simulated instrument before working with the real thing.

This section focuses on using the Oscilloscope and the Bode Plotter in Multisim's simulated environment. The period, amplitude and frequency will be determined from a waveform supplied by the file **Scope1.ms10**. Students will be introduced to the RMS conversion feature on the voltage source.

The file **Scope2.ms10** contains a circuit shown at the scope's initial settings. The accompanying worksheet will challenge students to predict which Oscilloscope controls, as well as their direction of adjustment, should be moved to best observe the waveform. Amplitude and phase shift will be measured using **Scope2.ms10**. A lowpass filter is provided in the file **Scope3.ms10**. Measurements at 3dB points will be taken with the Oscilloscope so that the student fully understands the usefulness of the Bode Plotter.

An additional Oscilloscope tutorial can be found in the file **AgilentOscilloscope.ms10**. An additional low pass and a high pass filter are provided in the circuit files **Filter1.ms10** and **Filter2.ms10**. A band-pass filter and a band-stop filter are also included in files **Filter3.ms10** and **Filter4.ms10**. These files are named so that the student does not know which kind of filter each contains.

Introducing the Oscilloscope

Goal

To introduce the student to the proper use of an Oscilloscope for measurement of the frequency and amplitude of a repetitive waveform.

Prerequisites

You will require circuit file **Scope1.ms10**.

It is assumed that the student:

- Is familiar with the basic concepts of graphing, setting coordinates for graphs, frequency, period and amplitude
- Can convert from RMS to peak and peak-to-peak values for sine waves
- Has had an introductory exercise (lecture, video, text reading assignment, etc.) on basic Oscilloscope functions, including setting the vertical axis sensitivity (V/Div) and horizontal axis (TIME BASE) to achieve the best possible accuracy.

Comments

Two worksheets and two circuit files are included. Students are first asked to calculate period, amplitude and frequency using circuit file **Scope1.ms10**. The file **Scope 2.ms10** is used in conjunction with the second worksheet. It provides a signal generator connected to an Oscilloscope set to initial settings. The worksheet challenges the student to think about the relationship between the display, which controls to change and in which direction to change them in order to efficiently obtain a display of meaningful values.

Note At any point during simulation, the student may click on the Pause button to freeze the simulation, and take more accurate measurements.

Procedure

This lesson can be done with a lecture approach, using Multisim to demonstrate the use of the scope. I suggest that if you follow this approach, you should supply your students with the worksheet that follows this lesson to help focus their attention on the topic.

Have each student complete the worksheet. Upon completion, discuss the results as a class.

Relevant Worksheets

- “Worksheet 2-1: The Oscilloscope 1”
- “Worksheet 2-2: The Oscilloscope 2”
- “Worksheet 2-3: Measuring Amplitude and Phase Shift with the Scope”.

Extension Ideas

You will need the following files:

- **Scope2.ms10** for the basic scope exercise
- **Scope3.ms10** for phase shift measurements
- **AgilentOscilloscope.ms10** for additional basic scope exercise.

After the three familiarization exercises (**Scope1**, **Scope2** and **AgilentOscilloscope**) presented here, students still need practice and familiarization with the Oscilloscope. You may want to follow with a sequence of Oscilloscope lessons that familiarize the student with these functions of the Oscilloscope:

- AC/DC coupling and measurement of DC voltages
- Applications for the vertical and horizontal position controls
- Operation and applications of the triggering functions
- AUTO, A, B, EXTERNAL
- Phase shift measurements (time domain)
- Phase shift measurements using Lissajous figures
- Applications for the B/A and A/B control settings.

Phase Shift Measurements with the Scope

File **Scope3.ms10** provides an example of combined phase and amplitude measurements on a simple RC filter. A suggested student worksheet is included in the file’s Description Box.

References

Topic	Reference
Function Generator	Multisim User Guide: Ch. 8 “Instruments”
Oscilloscope	Multisim User Guide: Ch. 8 “Instruments”

Introducing the Bode Plotter

Goals

- To introduce the concept of analyzing frequency-selective circuits utilizing the Bode Plotter
- To relate the Bode Plotter display to the voltage response and (optionally) to the phase shift in a sample circuit
- To illustrate the usefulness of the Bode Plotter to support such mathematical concepts as ratios, logarithms and decibels.

Prerequisites

You will need circuit files **Filter1.ms10** and **Filter2.ms10**.

It is assumed that the student:

- Knows how to calculate capacitive and inductive reactance
- Can combine resistors with capacitors and inductors to obtain total impedance
- Can calculate phase angles for reactive circuits graphically or by using a calculator
- Can recognize Oscilloscope traces showing the amplitude and phase shift between two sine waves and can measure amplitude of sine waves on a scope
- Can convert a voltage ratio to decibel notation and decibels to voltage ratio (optional).

A Few Notes on Bode Plotter Operation

1. On the vertical axis:
 - **F** indicates FINAL value. In Linear mode, it is the maximum expected ratio of output to input. In LOG mode, it is the maximum expected decibel gain or attenuation
 - **I** indicates the INITIAL value. In LIN mode, it is the minimum expected ratio. In LOG mode, it is the minimum decibel gain or attenuation.
2. On the horizontal or frequency axis:
 - **F** is the maximum desired frequency and **I** is the minimum desired frequency needed to display the frequency response of interest.
3. The vertical cursor, which moves in the horizontal axis only, allows accurate measurements to be taken easily.
 - A digital readout gives the coordinates of the intersection of the cursor and the plotted curve.
4. When using the Bode Plotter, you need a signal source. Either the Function Generator or a sine wave voltage source is acceptable.

How the Bode Plotter Helps Teach Frequency Response

Many teachers would like to introduce frequency response as soon as they can because it shows that even simple circuits can have important applications. They are sometimes deterred because, in addition to AC theory, it seems to require more mathematics.

The mathematical analysis of a low-pass circuit is challenging, but the concept itself is not. The principle can be simply stated:

- At low frequencies the output voltage from a low-pass filter is almost as large as the input voltage
- As the input frequency increases, the output voltage drops.

From this statement, students can conclude for themselves that there must be a *cutoff frequency* at which the transition takes place.

Printouts of Multisim Bode plots may be used to produce overheads showing progressive response curves as the circuit values vary. Such overheads are also useful for handouts, especially if PowerPoint is not available.

The Bode Plotter is an ideal tool for introducing your students to filters and resonant circuits. The concept of frequency response can be clearly illustrated by the amplitude response with frequency as displayed on the Bode Plotter.

Because instrument availability is not an issue when using Multisim, it is possible to invert the order of discussion about frequency response if desired:

- First, the Bode Plotter's graph gives a picture of the overall frequency response of the circuit. The cutoff (corner) frequency, for instance, is obvious on the log-log Bode plot
- Students have seen the results on the Bode Plotter, so you can discuss how to measure these same things on the Oscilloscope. Students will know what to expect when they embark on the time-consuming task of plotting a filter response using the Oscilloscope.

The Bode Plotter lets you present an overall discussion of frequency response. Once the concepts are understood through an examination of the Bode graphs, you can introduce subsequent theory, knowing that the overall picture is understood.

The results are even more startling when you demonstrate resonant circuits. The resonant frequency of a series RLC circuit is obvious on the Bode plot. The concept of bandwidth becomes easy to teach when referring to a Bode plot diagram.

The Low-Pass Filter

Ask the class to imagine what happens to the output voltage as the source frequency is increased. After some discussion, they should realize that decreasing the impedance of the capacitor would affect the output. Once the students understand that the voltage across the capacitor will decrease, they are prepared to work with circuit **Filter1.ms10**, in which a Bode Plotter is attached to an RC network, as shown in the next diagram.

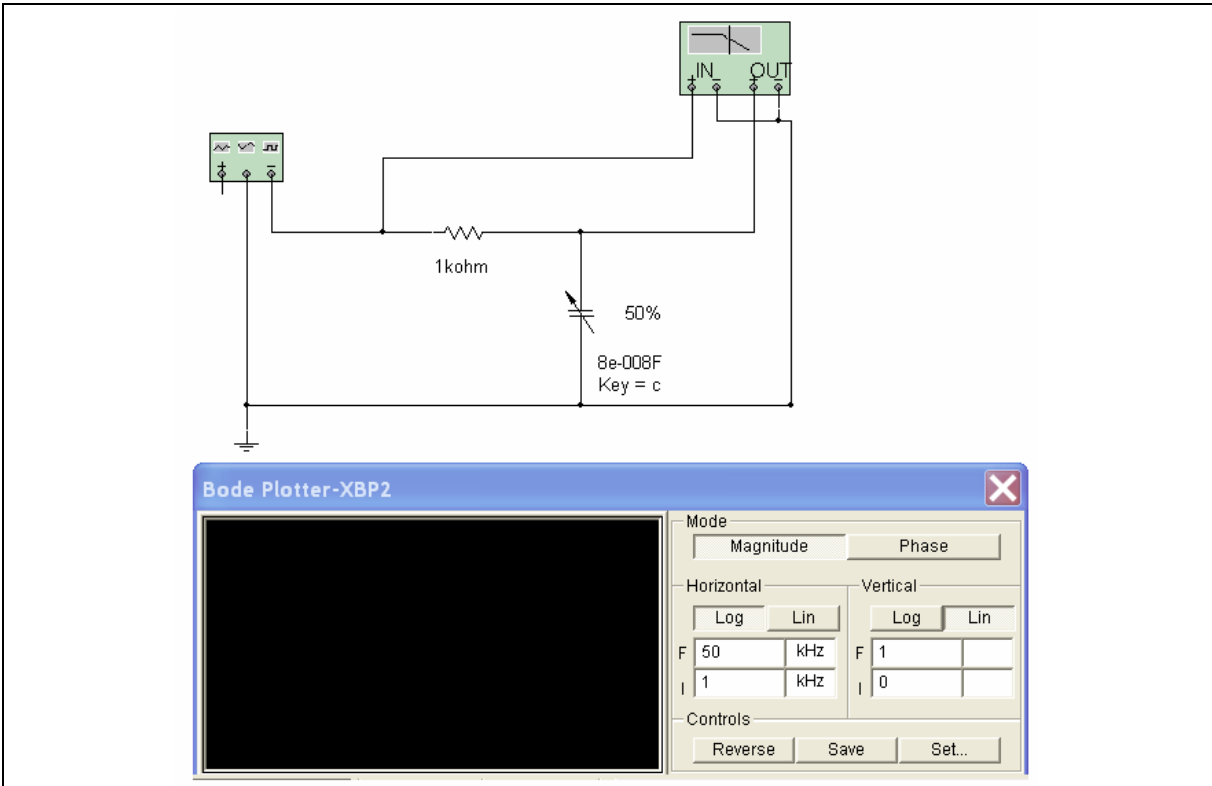

Figure 2-1: Filter1.ms10

If the LOG option is used on both horizontal and vertical scales, the Bode plot shows that the output is (nearly) constant until the cutoff frequency is reached. After this, the output falls linearly with frequency.

If the LIN option is used on the vertical scale and the LOG option for the horizontal scale the Bode plot shows that the output falls with frequency.

Once the overall behavior is made obvious by this graph, you may wish to have your students make measurements at specified frequencies, using the marker feature of the Bode Plotter. All they have to do is identify a frequency range of interest and choose the proper settings for the linear ranges.

Note The readout of the marker position is given as a *ratio* of output to input, not as absolute voltage.

At this point in the discussion you may wish to change to PHASE measurement to show the phase shift of the circuit with frequency. Measuring the phase at various frequencies will add to students' basic concepts of circuit behavior.

Once students know how to measure phase shift using the Bode Plotter, get them to replace the Bode Plotter with the Oscilloscope, for example in circuit **Scope3**. They can practice measuring phase difference the traditional way, using an Oscilloscope.

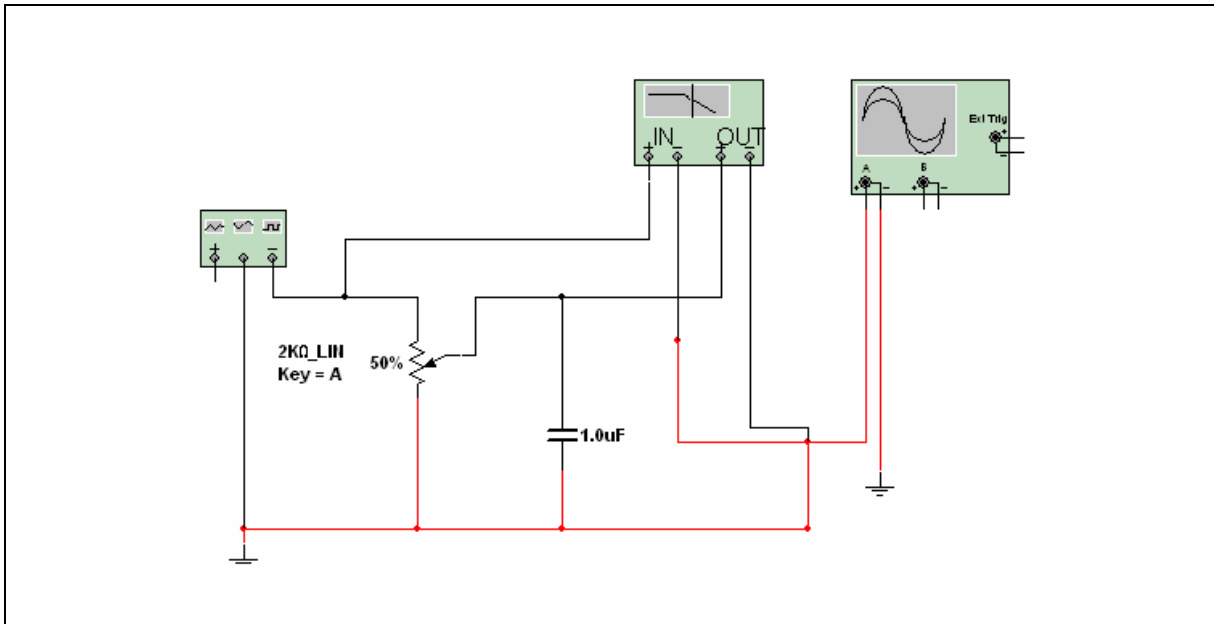

Figure 2-2: Scope3.ms10

When students have made measurements on the Bode Plotter, they are ready for some analytical work. They can make calculations at a few selected frequencies to confirm the readings. Some students will become more comfortable with logarithmic quantities and strengthen their ability to convert back and forth from decibels to ratios.

Also, they can attach an Oscilloscope instead of the Bode Plotter and confirm results for a chosen frequency, such as the corner frequency. Here, the output wave will be 0.707 of the voltage source and 45° out of phase. When students realize that they can use the Bode Plotter rather than repeat voltage ratio and phase calculations endlessly, they will be much more receptive to mastering frequency response concepts.

When the basic concepts have been illustrated, you can change the resistance using the variable resistor in the circuit. If appropriate, students may be asked to work with the new circuit using either of the sample worksheets on the following pages.

Relevant Worksheets

“Worksheet 2-4: The Low-Pass Filter”.

Series RLC Resonant Circuit as a Filter

After studying non-resonant filters, where the output voltage is always less than the source voltage, students are generally surprised to find that some passive circuits produce output voltages many times greater than the source voltage.

Suggested Procedure

You can ask your students to predict the response curve for a series RLC circuit. Then help them to understand why the output voltage peaks at the resonant frequency. The Bode Plotter's graph makes the results very clear. You can see the effect that circuit resistance has on the resonance peak and how changing capacitance or inductance values shifts the resonant frequency. After doing this type of qualitative work, students should be more willing to undertake some calculations to verify their observations.

Prerequisites

You will need the following files:

- **Filter1.ms10**
- **Filter2.ms10**
- **Filter3.ms10**
- **Filter4.ms10**
- **Wizard1.ms10**

Relevant Worksheets

“Worksheet 2-5: Series Resonant Circuit as a Filter”.

Extension Ideas

After investigating the basic characteristics of this series resonant RLC circuit, further investigations may be carried out by observation of the effect of changes of L or C on resonant frequency and changes of circuit resistance on bandwidth.

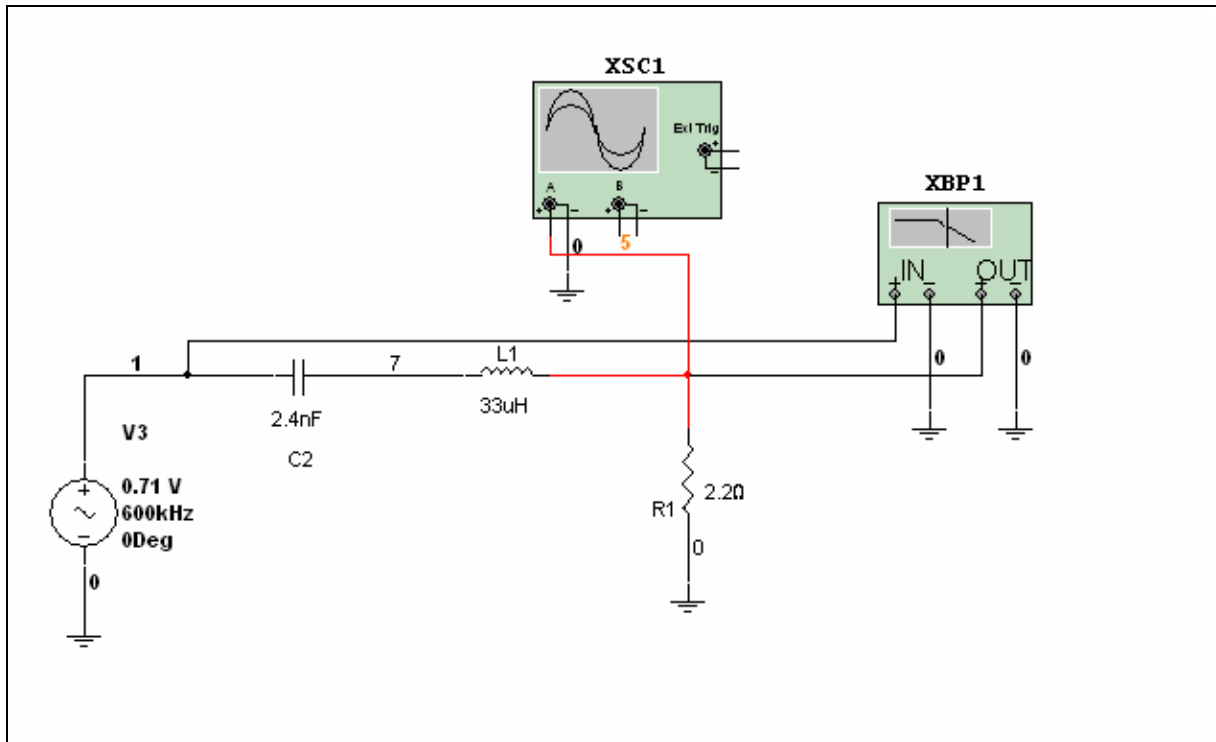

Figure 2-3: Filter3.ms10 showing Bode Plotter

Simultaneous Comparison: Active and Passive Filters

File **Filter2.ms10** shows how to use Multisim to simultaneously compare the characteristics of two circuits that (in theory) perform the same function. (In this case, they are a low-pass filter implemented with simple RC and an active filter using an op-amp).

This file lets students compare the circuit characteristics, both loaded and unloaded, and see the advantage of one circuit over the other.

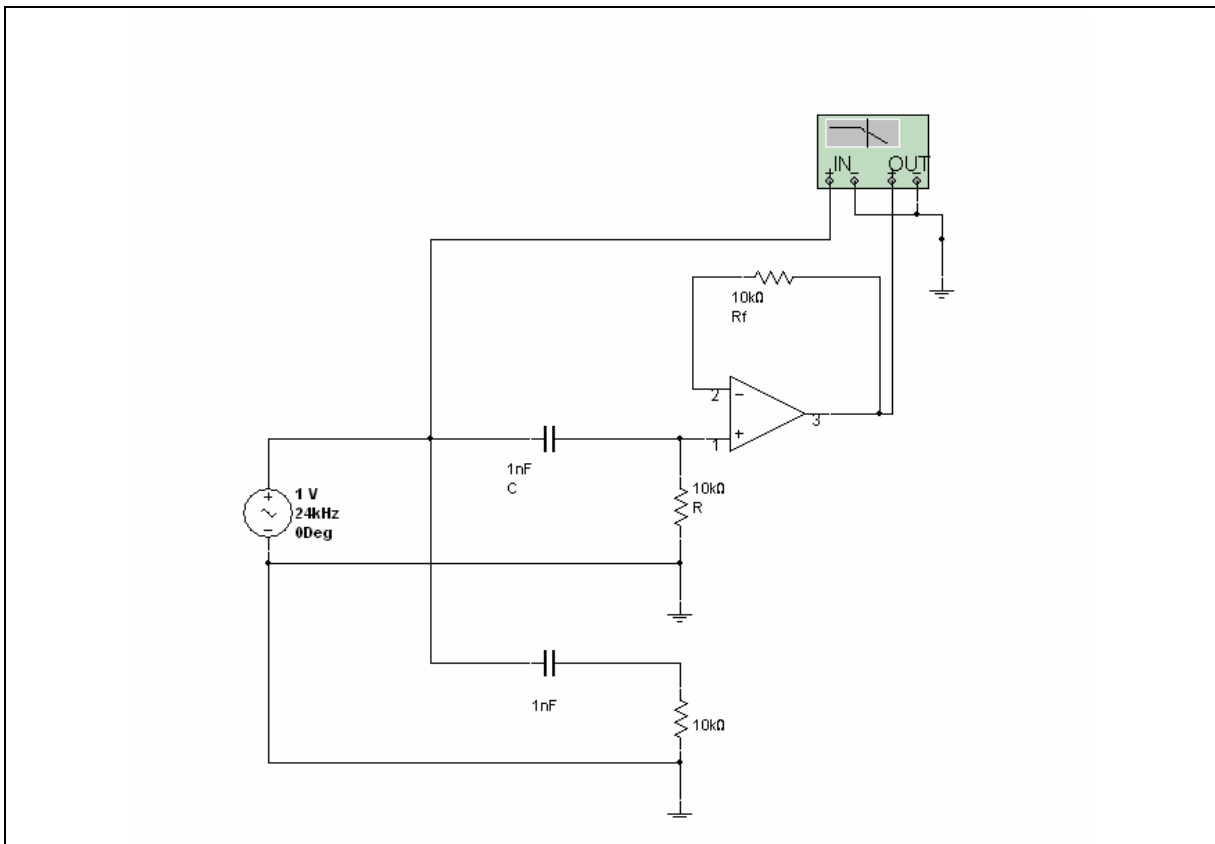

Figure 2-4: Filter2.ms10

Multisim lets students investigate both circuits simultaneously, to evaluate the advantages or disadvantages of each circuit. The advantage of the active filter can be illustrated by loading each circuit with an appropriate value (say the same as the resistance of the filter).

A suggested worksheet for the basic investigation of each circuit is included in the file's Description Box.

Agilent Oscilloscope

Goal

To familiarize the student with Multisim's Agilent Oscilloscope and to demonstrate the advantages of having students use a real oscilloscope in a simulated environment. This lab also demonstrates one advantage of using the Hierarchical block available in Multisim.

Comments

The Agilent Oscilloscope can be found in the Instruments toolbar.

Procedure

1. Open **AgilentOscilloscope.ms10**.

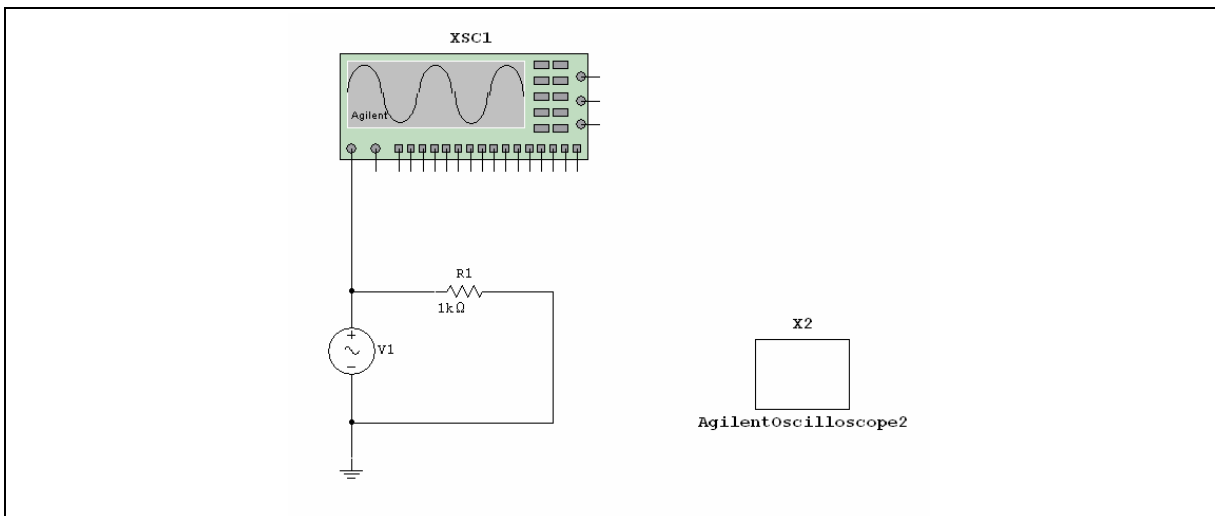

Figure 2-5: AgilentOscilloscope.ms10

2. Open the Description Box and complete the steps for all of the hierarchical blocks.
3. Run the simulations by clicking on the switch or selecting **Simulate/Run**.

Wizard

Goal

To familiarize the student with Multisim's filter generating feature. To demonstrate the advantage of the Wizard feature when studying filter behavior.

Comments

The Filter Wizard can be found under the Tools menu.

Procedure

1. Open **Wizard1.ms10**.
2. Open the Description Box and complete the steps.
3. Run the simulations by clicking on the switch or selecting **Simulate/Run**.

Additional Challenge

Three circuit files contain faults and are denoted with the letters "TS". These faults may be observed by de-selecting the **Hide component faults** checkbox found under **Options/Circuit Restrictions/General tab**, then double-clicking on the components and sources. If you provide a password, you may prohibit student access before distributing the files. Description Boxes are used to guide the student through the troubleshooting process. Promoting problem-solving logic is further encouraged in the troubleshooting section of this workbook. The troubleshooting files are **Filter1TS.ms10**, **Filter3TS.ms10** and **Filter4TS.ms10**.

Worksheet 2-1: The Oscilloscope 1

Name: _____ ID Number: _____ Class: _____

Starting Point

Open circuit file **Scope1.ms10**.

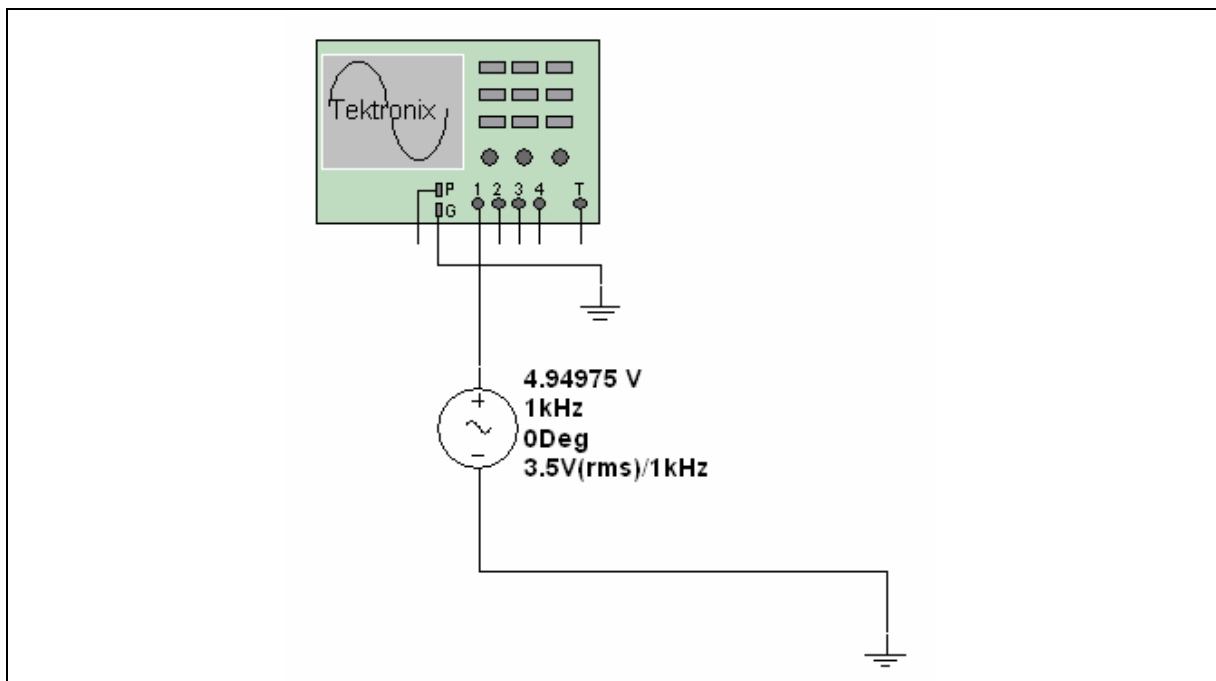

Questions

1. Calculate the peak-to-peak amplitude of the signal.

Vout (p-p) = _____ volts

2. Calculate the period of the signal.

T = _____ = _____ seconds or _____ msec

3. Determine the setting of the V/Div control so that the displayed waveform will be approximately four divisions (vertical) but the peak of the sine wave will not exceed the upper or lower limits of the screen (the peak of the wave should not be clipped or flattened).

REQUIRED V/DIV setting = _____

4. Determine the setting of the TIME BASE control so that approximately two cycles of the waveform will be displayed (horizontal).

REQUIRED TIME BASE setting = _____ ms/div

5. Set the scope controls to the calculated values, and then simulate the circuit by clicking the power switch or selecting **Simulate/Run** from the menu. Confirm that the settings give the required display.

Note: For best accuracy of measurement, left-click on the **Pause** button to freeze the waveform.

6. Measure the period by measuring the number of divisions x time between peaks or crossover points.

T1 = _____

T2 = _____

Period (T2 - T1) = _____

Calculated frequency (Hz) = _____

7. Measure the peak-to-peak voltage

Voltage at positive peak = _____

Voltage at negative peak = _____

Peak-to-peak voltage = _____

8. Confirm that the measured results conform, within reasonable limits, to the values on the schematic.
9. Comment on any factors that introduce discrepancies between the actual frequency and amplitude and their measured values.
10. Double-click on the AC supply to view its settings. Notice the Voltage Amplitude setting and the Voltage RMS setting below it. Try changing the amplitude setting and observe the resulting RMS voltage.

Worksheet 2-2: The Oscilloscope 2

Name: _____ ID Number: _____ Class: _____

Starting Point

Open file **Scope2.ms10**.

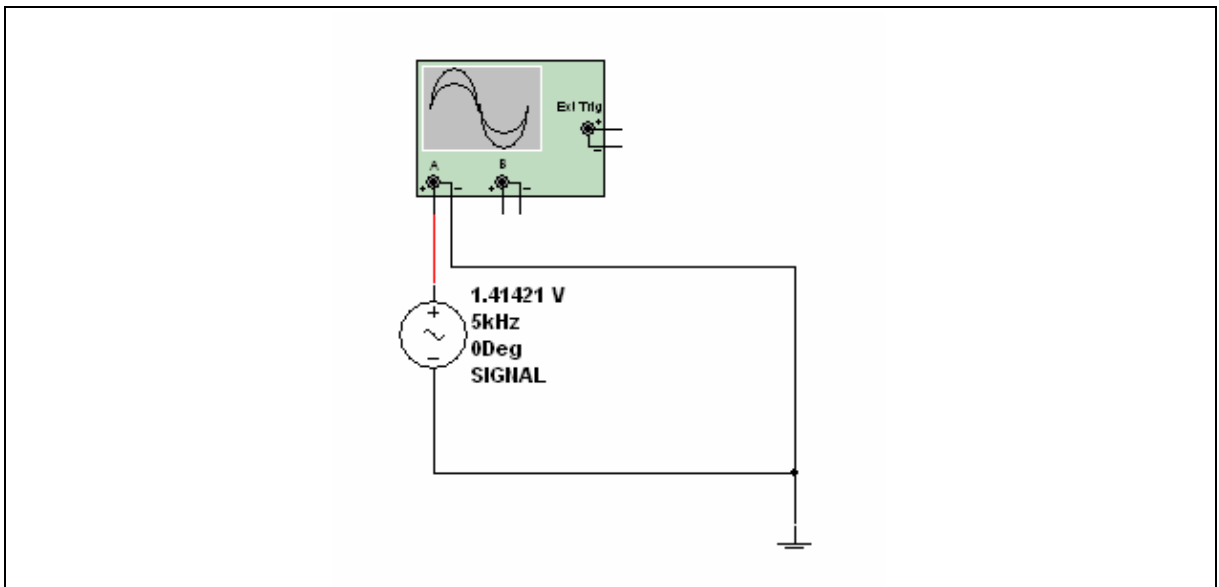

Questions

1. Solve the circuit, using the power switch.
2. For best observation and accuracy of settings, click on the **Pause** button to freeze the waveform in the Oscilloscope window. Analyze the initial display:
 - a) Should the TIME BASE setting be increased (more time/division) or decreased (less time/division) in order to make accurate measurements? Explain your choice.

 - b) Should the V/Div setting be increased (more V/division) or decreased (less V/division)? Explain your choice.

 - c) Which control should be adjusted first so that the peaks of the signal amplitude will be visible? Explain your choice.
3. Adjust the V/Div setting until the signal peaks are visible and the signal is *at least* three divisions on the screen.
4. Record the V/Div setting.

Worksheet 2-3: Measuring Amplitude and Phase Shift with the Scope

Name: _____ ID Number: _____ Class: _____

Starting Point

Open file **Scope3.ms10**.

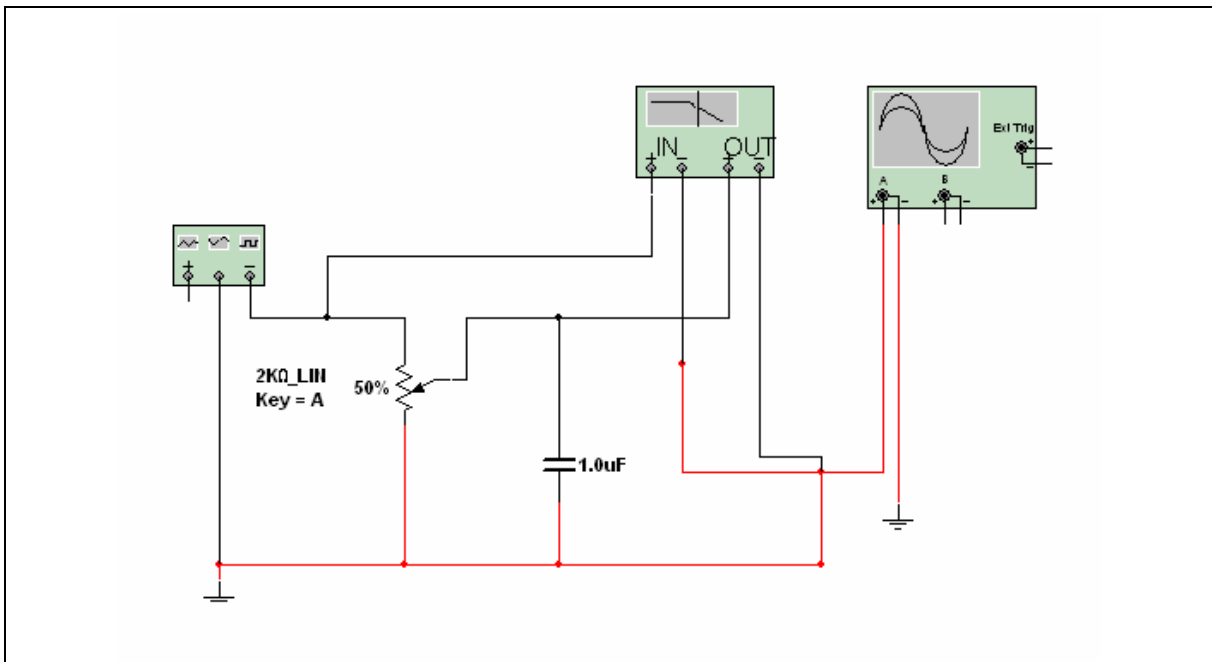

Notes

- A variable resistor has been included in the circuit. This lets you change values of R to show a change in the corner frequency or phase shift
- The resistance value shown is the maximum value of the variable. The default setting of variable components is at 50% of maximum
- Change the resistance by pressing the A key to increase the value and SHIFT-A to decrease the value. You can also hover the cursor over the variable resistor and drag the slider bar that appears.
- A variable capacitor and inductor are also available for use in such circuits.

Questions

1. Solve the circuit.

Note: Make sure the scope settings provide no more than two cycles of the waveforms (for accuracy).

2. Determine the ratio between input and output amplitudes and the time difference between two identical points on each waveform. Either the waveform peaks or the point at which each waveform crosses the zero line may be used for time.
3. Time difference between similar points from input to output (using successive peaks):
 - a) $T_1 - T_2 = \underline{\hspace{2cm}}$
 - b) Period of the waveforms = $\underline{\hspace{2cm}}$
 - c) Phase shift = $\underline{\hspace{2cm}} \times 360 = \underline{\hspace{2cm}}$ degrees
4. Does the output lead or lag the input in phase? Explain.

Worksheet 2-4: The Low-Pass Filter

Name: _____ ID Number: _____ Class: _____

Starting Point

Open file **Scope3.ms10**.

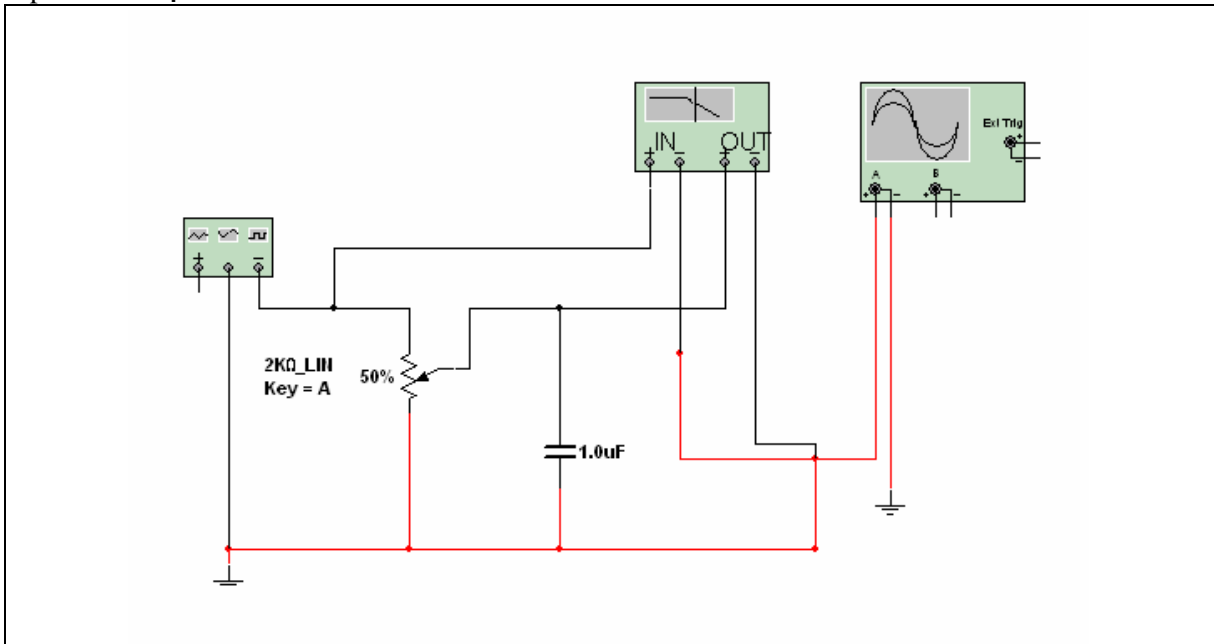

Notes

- The output of this circuit is approximately equal to the input (say within 5%) from 10 Hz or lower until a certain frequency is reached; then the output begins to drop (**attenuation** of the circuit begins to increase).

Questions

- Double-click on the Bode Plotter to open it.
- From the response curve determine the following:
 - When the output has dropped to (approximately) 95% of the input, the **RATIO** of output to input is _____.
 - The frequency at which this takes place is _____ Hz.

- c) Optional - Convert the input/output ratio to decibel notation. Show calculations.

At _____ Hz, the attenuation is _____ dB

3. At what frequency has the output dropped to (approximately) 70.7% of the input?

a) Freq. = _____ Hz

- b) Optional - Convert this ratio to decibel notation. Show calculations. Note that this is the -3 dB or corner frequency.

At _____ Hz, the attenuation is _____ dB

4. At what frequency has the output dropped to (approximately) 10% of the input?

a) Freq. = _____ Hz

- b) Optional - Convert this ratio to decibel notation. Show calculations.

At _____ Hz, the attenuation is _____ dB.

5. Explain, without calculations, why the output decreases as frequency increases.

6. Change the Bode display to PHASE and measure phase shift (leading or lagging) at the frequencies determined above.

a) Phase shift when output is 95% = _____ degrees.

b) Phase shift when output is 70.7% = _____ degrees.

c) Phase shift when output is 10% = _____ degrees.

7. Double-click on the Oscilloscope to open it. Observe the waveform. The frequency is 200 Hz.

The amplitude as measured on the scope is _____ V.

Questions

1. Run the simulation. Set the Function Generator to 100 Hz. Adjust the value of the potentiometer and observe the scope. What changes do you see? Explain.

2. Set up the circuit on the NI ELVIS prototyping board. Run the Function Generator and the Oscilloscope. Adjust the potentiometer and observe the changes. Explain any differences between empirical and simulated data.

Worksheet 2-5: Series Resonant Circuit as a Filter

Name: _____ ID Number: _____ Class: _____

Starting Point

Open file **Filter1.ms10**, **Filter2.ms10**, **Filter3.ms10** or **Filter4.ms10**.

Questions

1. Double-click on the Bode Plotter to open its window.
2. Set the Bode coordinates to:
 - Vertical: LIN, F = 1, I = 0
 - Horizontal: LIN, F = 50 kHz, I = 1 kHz.
3. What type of filter response is this? Circle one of:
 - high-pass
 - low-pass
 - band-pass
 - band-reject.
4. Measure the resonant frequency and the voltage gain at the peak of the response curve.
Fo = _____ kHz

Voltage Gain = _____
5. Measure the frequencies at which the voltage gain has decreased to (about) 70% of gain at the peak (-3 dB).
f1 (above Fo) = _____ kHz

f2 (below Fo) = _____ kHz
6. What is the difference between these two frequencies (the bandwidth of the filter)?
Bandwidth = _____ kHz

Conclusions from observations:

1. What is the relationship between the resonant frequency and the bandwidth (approximately) for all circuits?
2. How does this ratio compare with the voltage gain of the band-pass and band-reject circuits?

NI ELVIS Exercise

Starting Point

1. Create the circuit **filter2.ms10** on your NI ELVIS breadboard. The input for the circuit is simply the output of the function generator, and the output of the circuit is taken from the output pin of the Operational Amplifier.

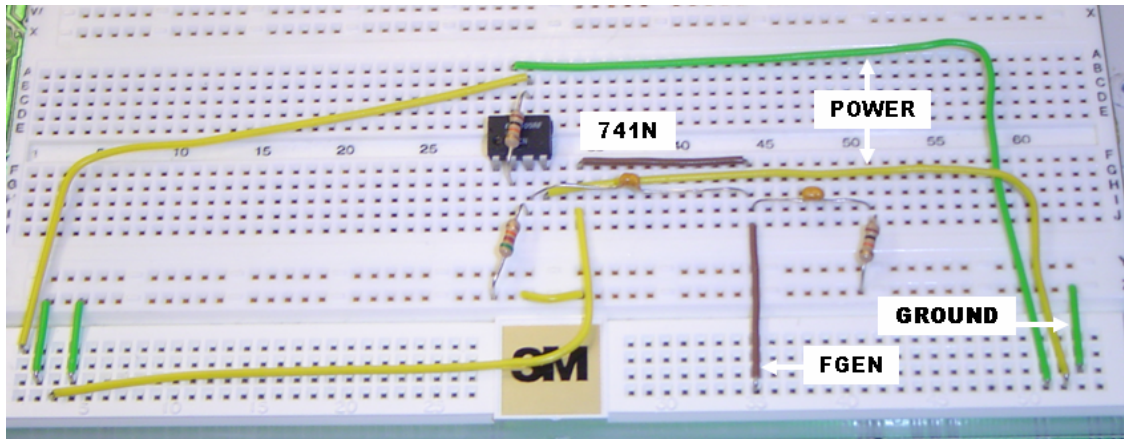

Notes

- You are creating an Active High-Pass Filter. This means that high frequencies are passed through the circuit with no attenuation, and low frequencies are attenuated.

Questions

1. After constructing your circuit, run the Bode Analyzer in NI ELVIS. Then open **filter2.ms10** and run that simulation. Compare the simulated Bode Analysis to the results attained from your Bode Analyzer.

2. What is the stop frequency for this high pass filter?
3. How would you change this circuit to increase or decrease the stop frequency?

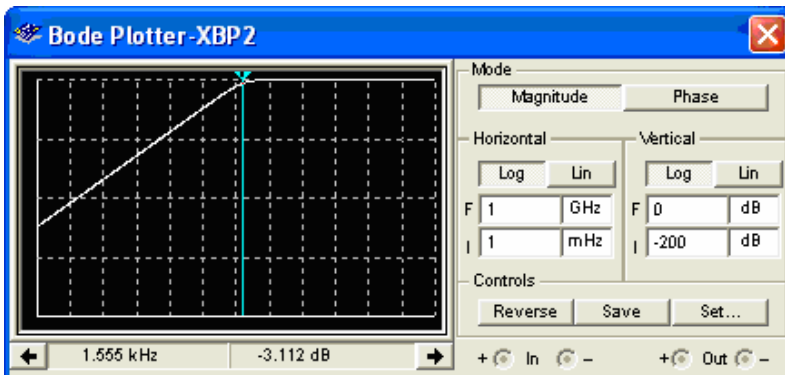
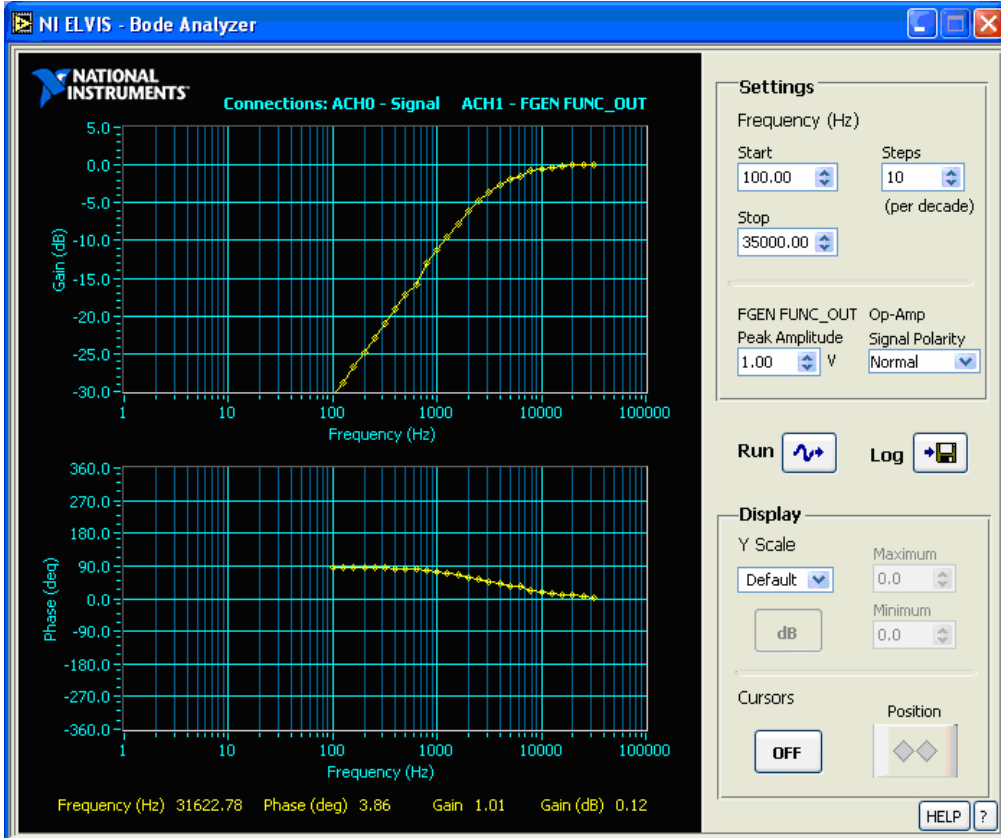

Section 3: Diodes

Section Contents

This section contains the following:

- “Introducing Diodes” on page 3-2.

Worksheets in this Section

The worksheets in this section begin on page 1 of: Worksheet 3-1: Clippers.

- “Worksheet 3-1: Clippers”
- “Worksheet 3-2: Clampers”
- “Worksheet 3-3: Clamper with LabVIEW Components”
- “Worksheet 3-4: Bridge Rectifier and Zener Diode”
- “Worksheet 3-5: IV Curve”.

Circuits for this Section

The following is a list of the file names of circuits used in this section and a brief description of each.

File (.ms10)	Description
BridgeRectifierWFilter	A bridge rectifier with a filter.
Clamper1	Two clamper circuits for student investigation.
Clamper2 ClamperLabView	Two clamper circuits for student investigation. Two clamper circuits using LabVIEW Instruments.
Clipper1	Three clipper circuits to be analyzed by the student.
Clipper1TS	Three clipper circuits of Clipper1 , which have been faulted.
ClipperApplications	Two practical applications of clipper circuits.
IV	I versus V analysis of a diode using Multisim’s IV analyzer
Transducer	This circuit makes explores different transducers
Zener	A file with two zener circuits for student investigation.
ZenerTS	A file similar to Zener.ms10 but which contains a fault.

Introducing Diodes

Fundamental to a well-rounded electronics education is a good understanding of semiconductor devices. Comprehension of the operation and various uses of diodes is an essential foundation for the pursuit of knowledge of more advanced devices.

Taking a little extra time to provide numerous diode examples for student analysis reaps its rewards when they attempt to comprehend transistor theory. If the student fully understands what happens when diodes are in forward or reverse bias, and various circuits where this can be utilized, the groundwork will be set.

This section deals with five clippers, four clampers, a bridge rectifier and two zener circuits. The clippers are found in the circuit files **Clipper1.ms10** and **ClipperApplications.ms10**.

The clampers are found in the circuit files **Clamper1.ms10** and **Clamper2.ms10**. Two circuits are contained in each file. The file **BridgeRectifierWFilter.ms10** contains a filter whose output is rippled DC. The zener diode file **Zener.ms10** contains two circuit files.

Prerequisites

- Students should have had an introduction to semiconductor theory, clippers, clampers and rectification.
- Students should be able to use the multimeter and Oscilloscope in the Multisim environment.

Worksheet 3-1: Clippers

Name: _____ ID Number: _____ Class: _____

Starting Point

Open the file **Clipper1.ms10**.

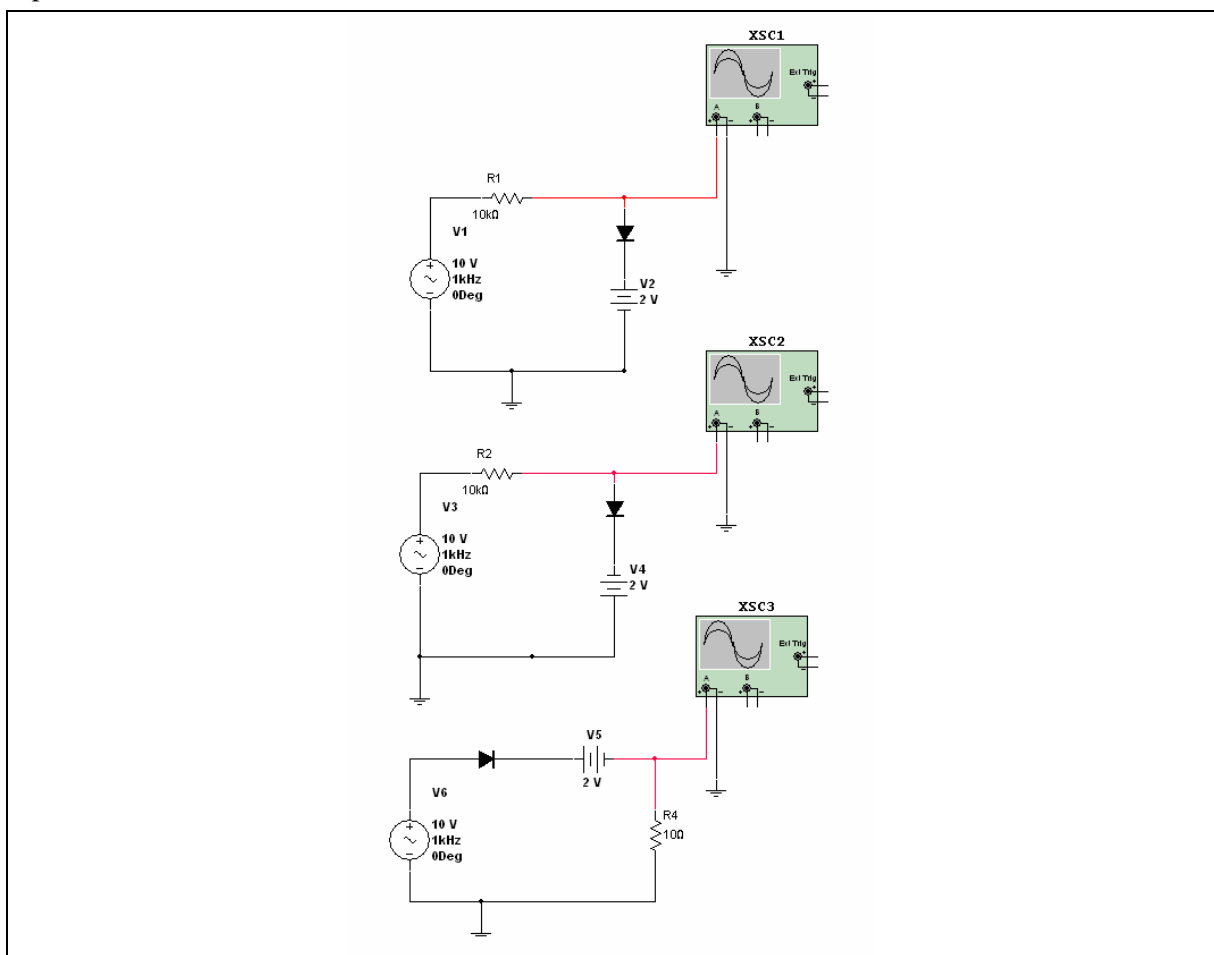

Questions

1. Using your understanding of how clippers work, draw the expected waveforms labeling each significant point (peaks and dc level).
2. Run the simulation by clicking on the switch or selecting **Simulate/Run**.
3. Double-click on the Oscilloscope to view its display.

4. Draw the output and compare with your results from step 1. Take the time to understand any discrepancies.

5. Open the file **ClipperApplications.ms10**.

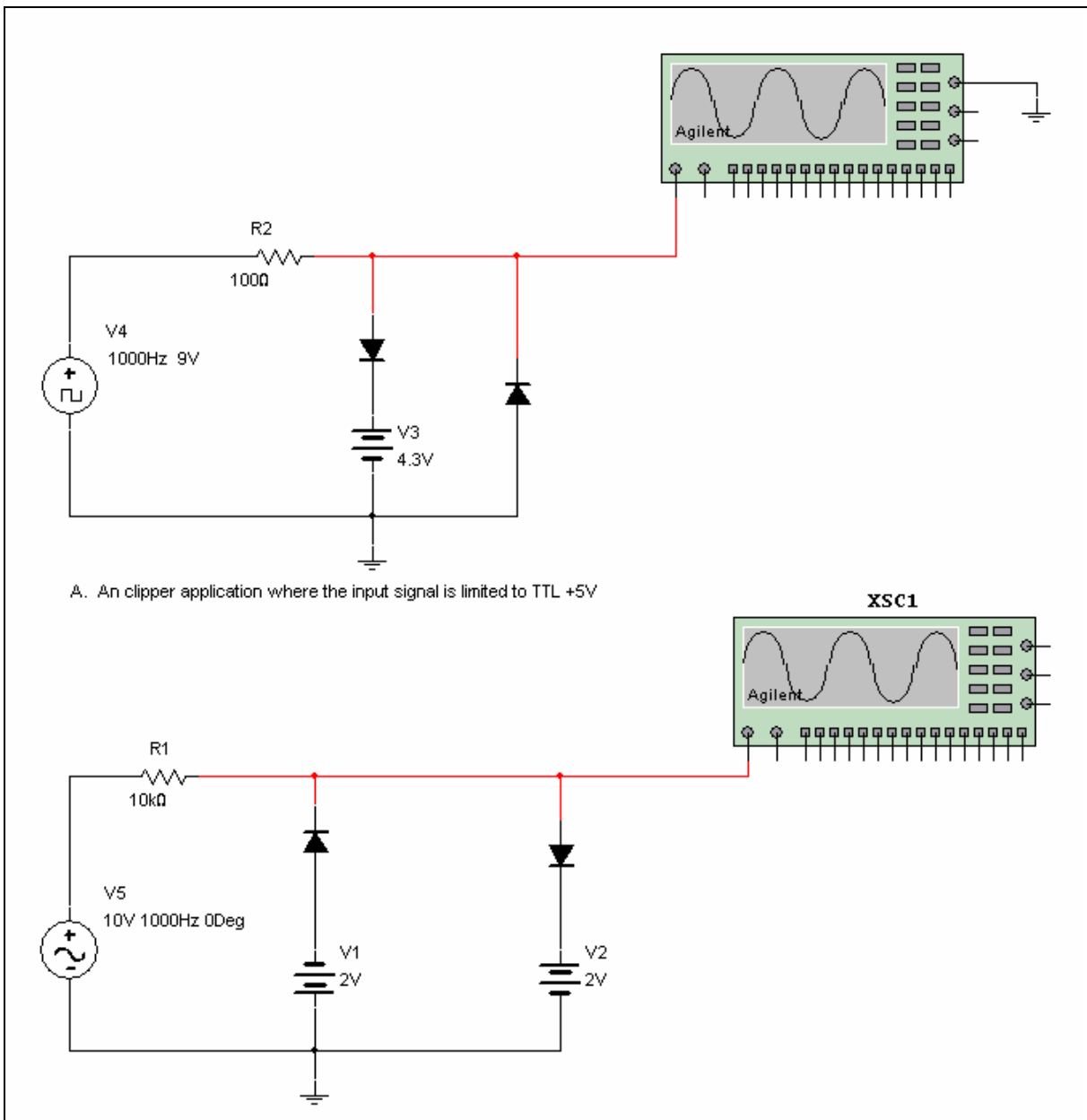

6. Analyze the circuits to gain an understanding of how they work.
7. Run the simulation and observe the results.

NI ELVIS Exercise

Starting Point

On your NI ELVIS breadboard, create the three circuits that you simulated and studied in the **Clipper1.ms10** file. The images below are examples for how you might implement these circuits.

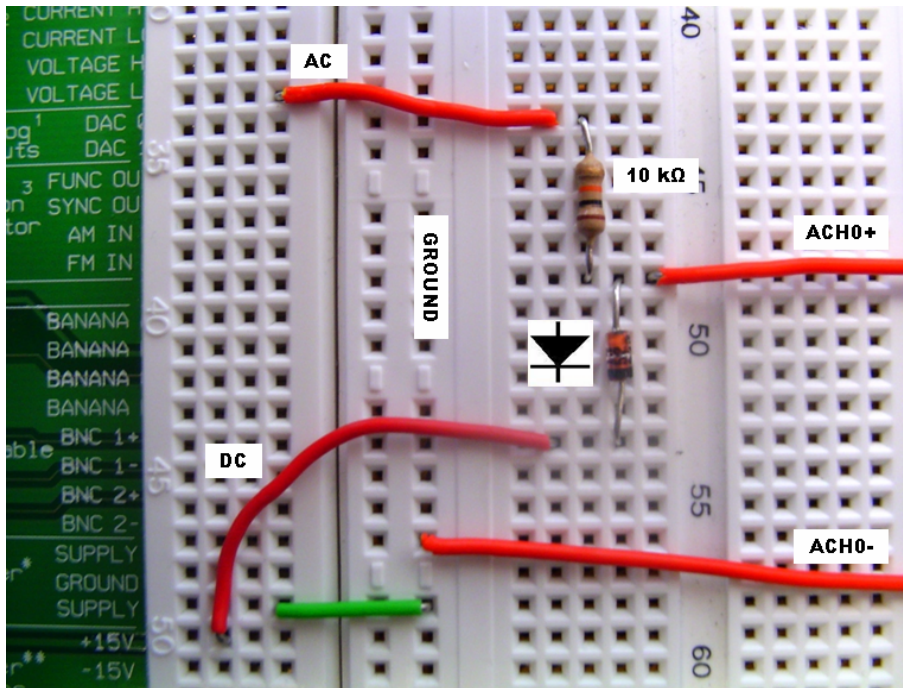

The first two circuits in **Clipper1.ms10** are exactly the same except for the DC voltage. One has +2 V and the other has -2 V. Above is an example how these circuits can be built.

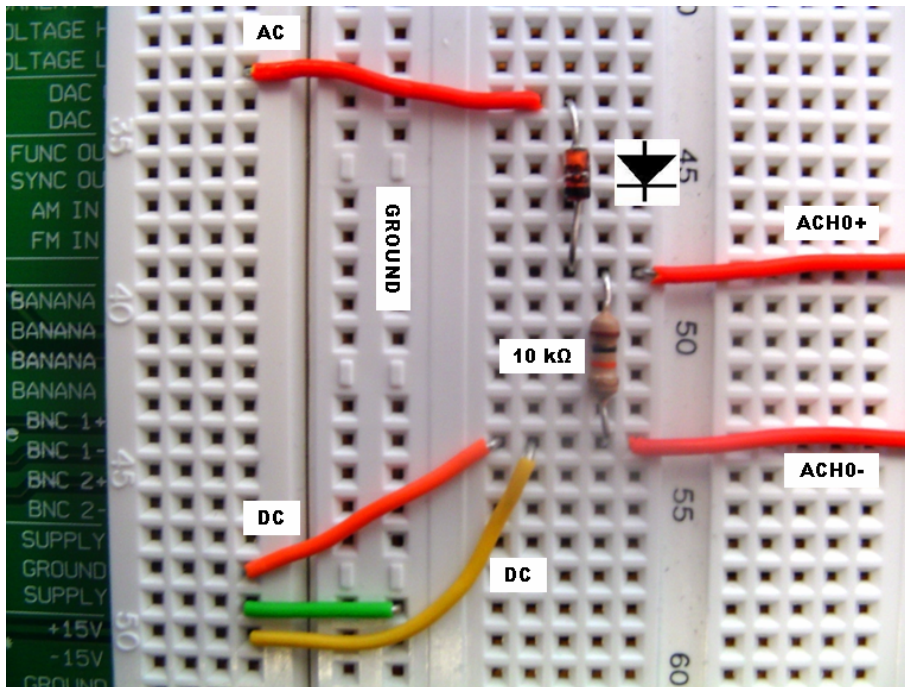

The last of the three circuits in **Clipper1.ms10** is shown above. A 10 k Ω resistor is used in place of the 10 Ω one used in simulation.

On your breadboard, create the two clipper application circuits from the **ClipperApplications.ms10** file. Again, you may use the images below for reference. Open **ClipperApplications.ms10** and run the simulations so you have a useful reference and a better idea of how the circuits function.

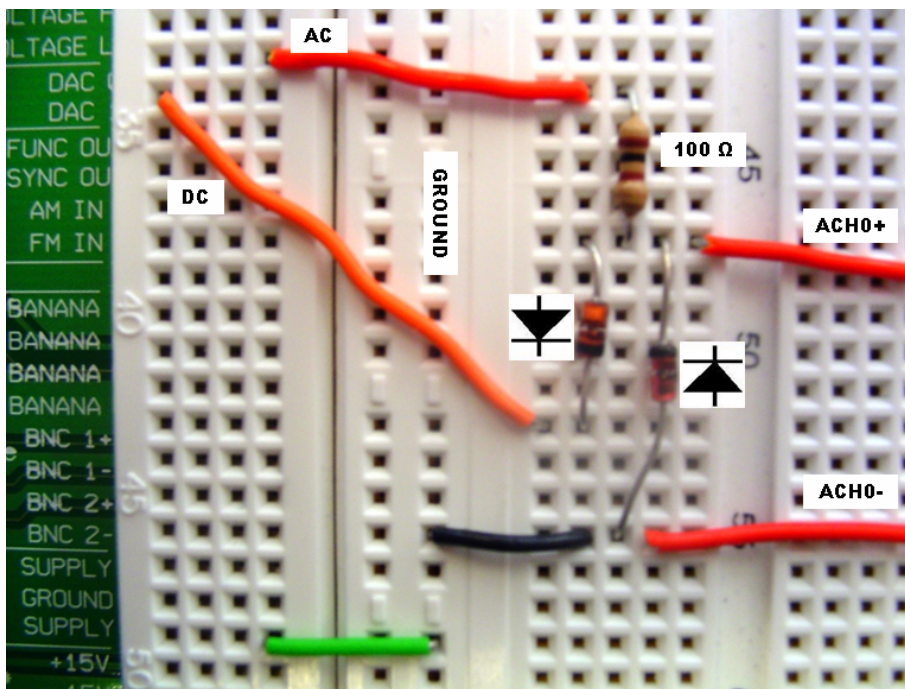

In the example shown above, analog outputs 0 and 1 are used to create the AC and DC signals for the circuit.

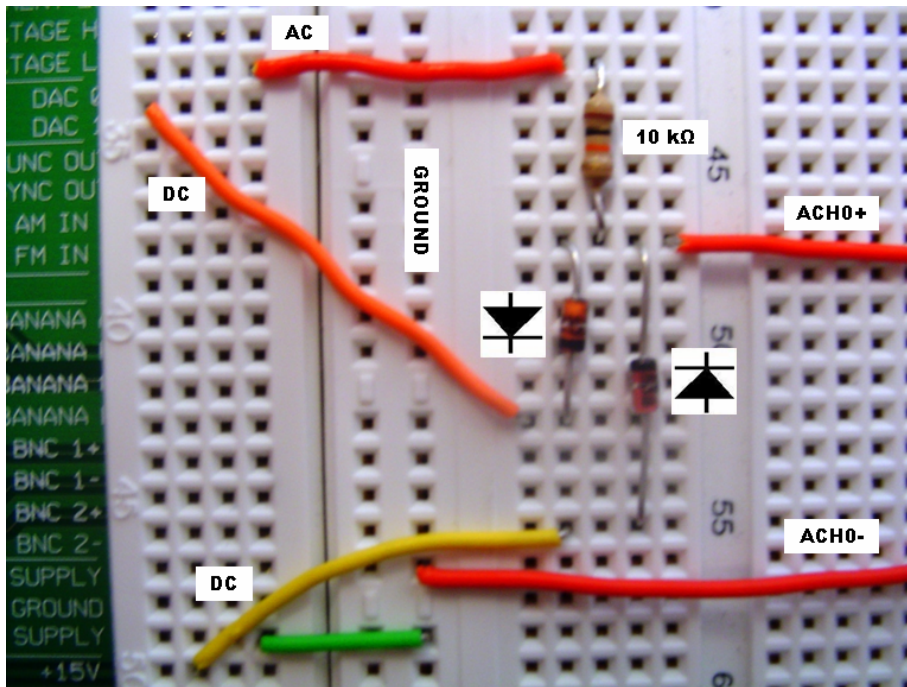

For clipper application circuit B, shown above, analog output 0 is used for the AC signal, analog output 1 is used for the positive DC voltage, and the variable power supply generates the negative DC voltage.

Notes

- In these NI ELVIS circuit implementations you may experiment with different ways to create the circuits on your breadboard. For instance, use either the analog outputs (DAC 0/1) or the function generator to create the input AC signals. Also, the DC voltages can be generated on the analog outputs or from the variable power supply. Experiment with these different options to get your circuits working properly.

Questions

- Analyze each of the circuits above using the diode theory you have learned in class.
- Compare your physical results using NI ELVIS with the simulations.
- Can you think of any more applications now that you've created five diode circuits? Consider different input signals and what outputs you might expect from them.

Worksheet 3-2: Clampers

Name: _____ ID Number: _____ Class: _____

Starting Point

Open the file **Clamper1.ms10**.

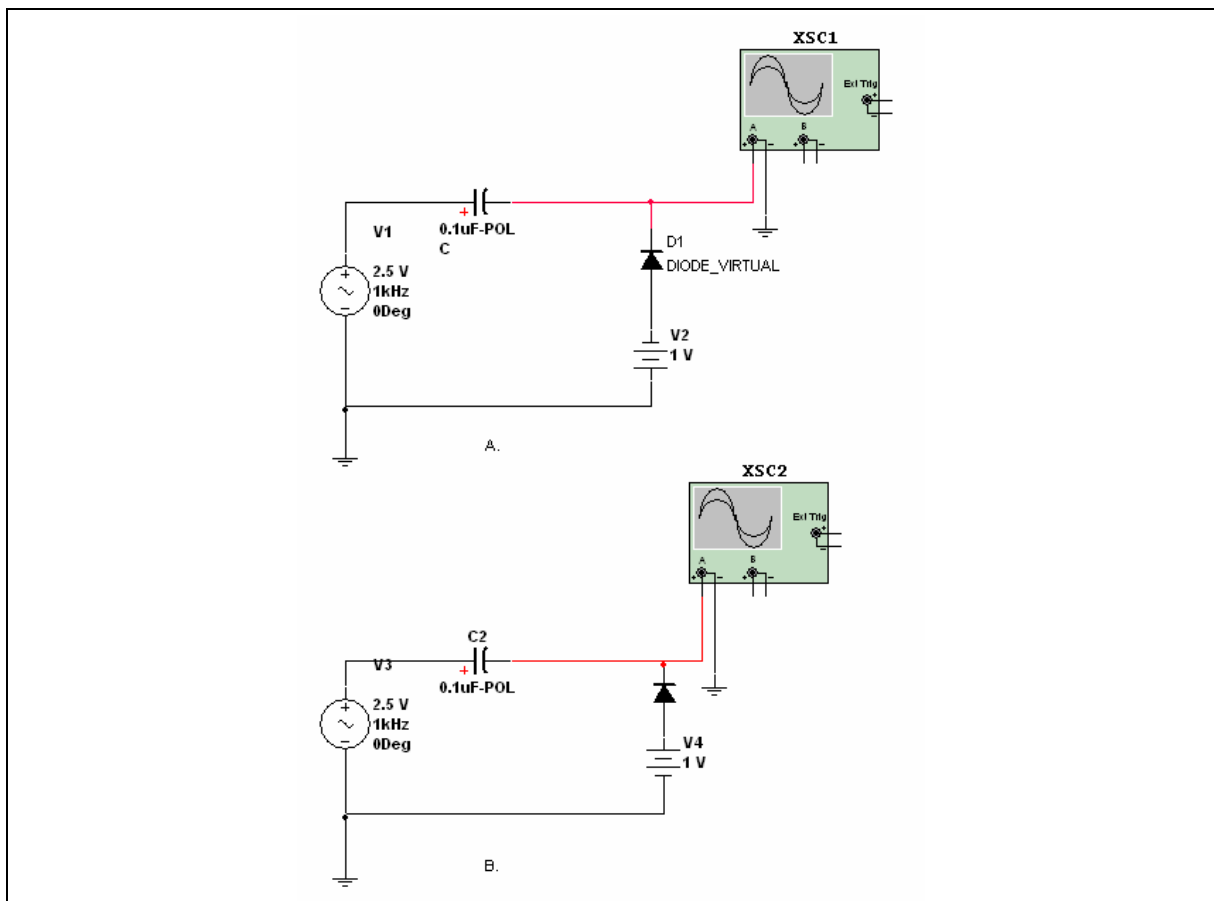

Questions

1. Using your comprehension of clampers and by reading the attached Description Box, draw the expected waveforms labeling each significant point (peaks and dc level).

2. Run the simulation by clicking on the switch or selecting **Simulate/Run**.
 3. Double-click on the Oscilloscope to view its display.
 4. Draw the output and compare with your results from step 1. Take the time to understand any discrepancies.
-
5. Open the file **Clamper2.ms10**.
-
6. Repeat steps 1 through 4.

NI ELVIS Exercise

Starting Point

On your NI ELVIS breadboard, create the two circuits that you simulated and studied in the **Clamper1.ms10** file. The image below is an example for how you might implement these circuits. Open **Clamper1.ms10** and run the simulations so you have a useful reference and a better idea of how the circuits function.

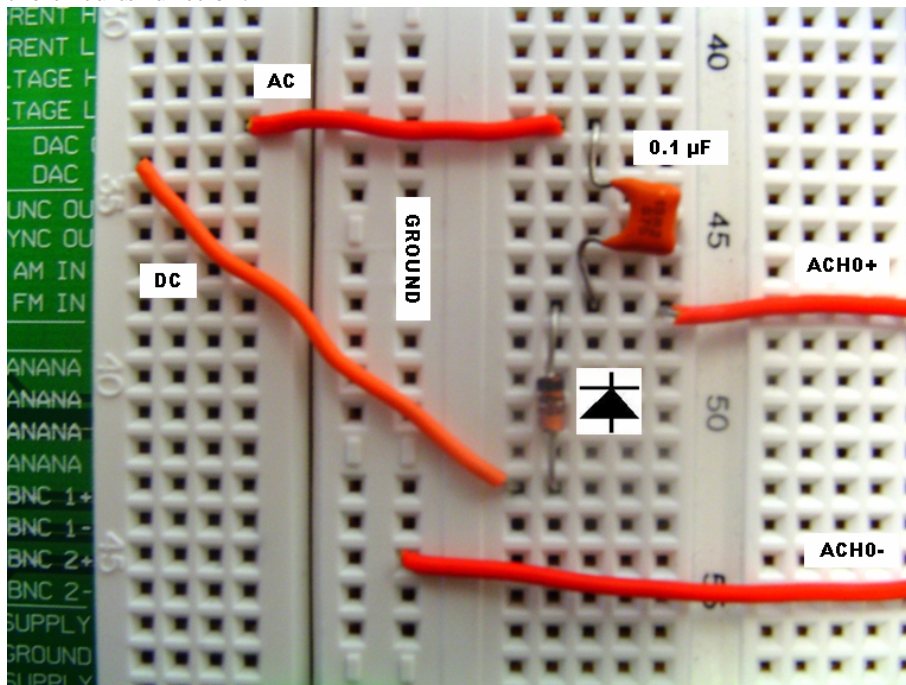

Notes

- In the following NI ELVIS circuit implementations you may experiment with different ways to create the circuits on your breadboard. For instance, use either the analog outputs (DAC 0/1) or the function generator to create the input AC signals. Also, the DC voltages can be generated on the analog outputs or from the variable power supply. Experiment with these different options to get your circuits working properly.
- As you work with these clamper circuits, keep in mind that the capacitive element may build up and charge that can affect your circuits' performance. While testing, it may be necessary to tie the capacitor to ground so that the voltage it is holding is discharged.

The first circuit in **Clamper1.ms10** has a positive DC voltage and the second one has a negative DC voltage. The implementation above uses analog output 1 to create the DC values for the circuit.

Now, on your breadboard, create the two clamper circuits from the **Clamper2.ms10** file. Again, you may use the image below for reference. Open **Clamper2.ms10** and run the simulations so you have a useful reference and a better idea of how the circuits function.

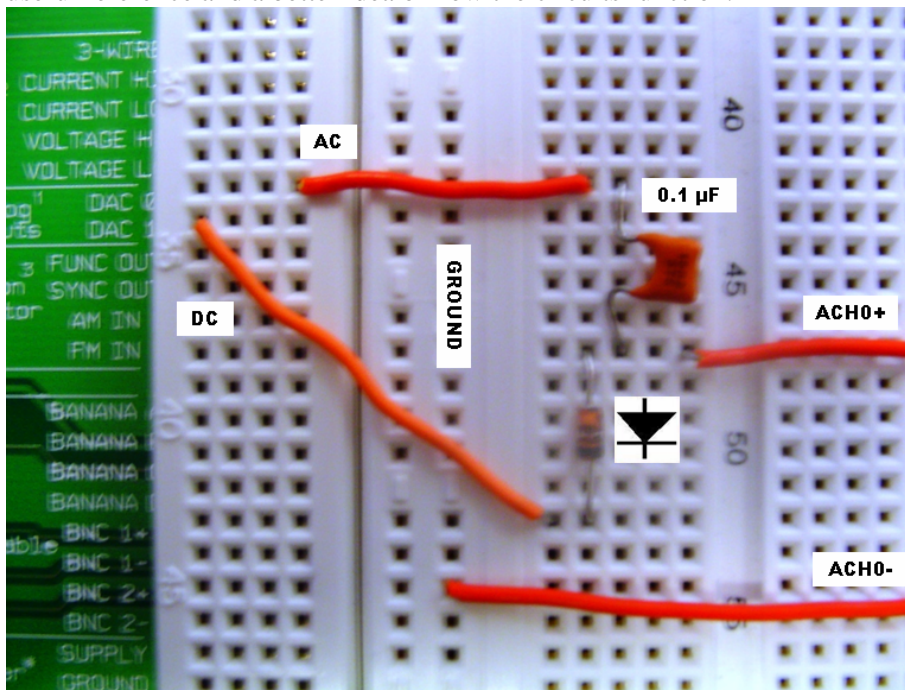

The first circuit in **Clamper2.ms10** has a positive DC voltage and the second one has a negative DC voltage. The implementation above uses analog output 1 to create the DC values for the circuit.

Questions

1. Analyze each of the circuits above using the diode theory you have learned in class.
2. Compare your physical results using NI ELVIS with the simulations.
3. Can you think of any specific applications for clamper circuits?

Worksheet 3-3: Clamper with LabVIEW Components

Name: _____ ID Number: _____ Class: _____

Starting Point

Open the file **ClamperLabView.ms10**.

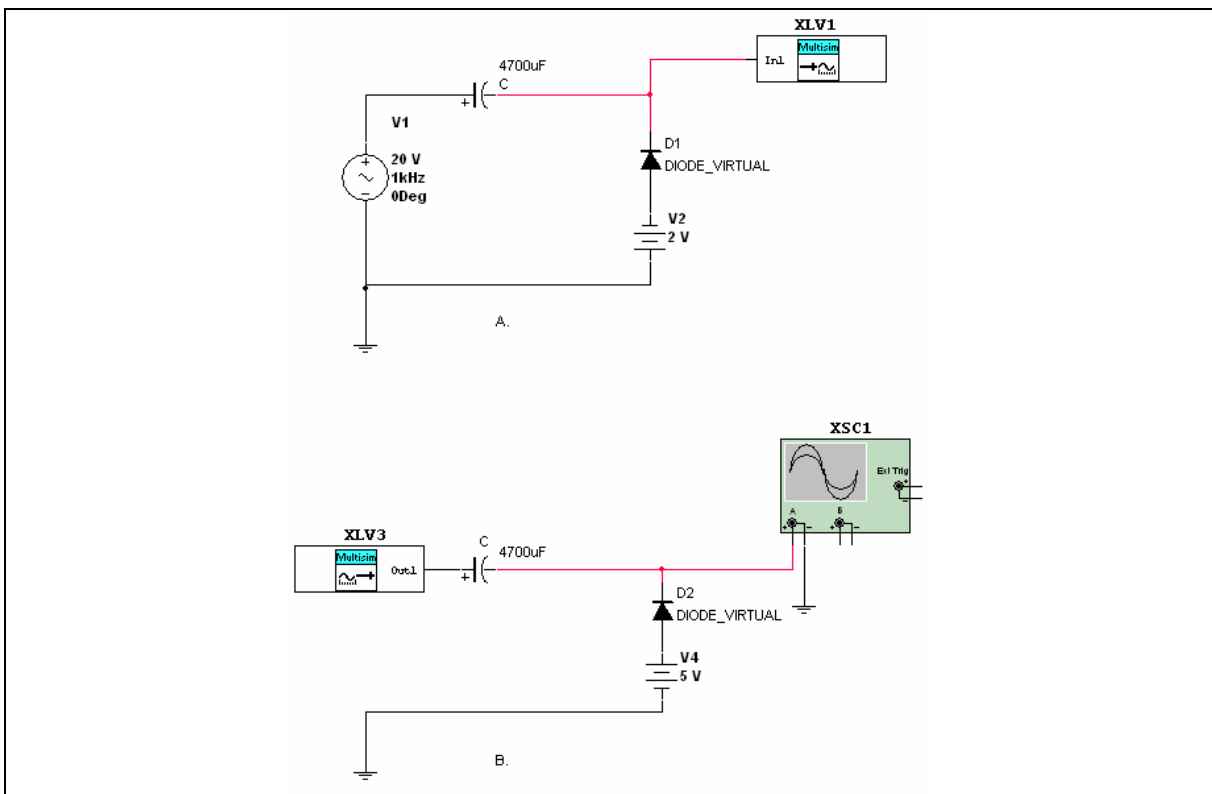

Questions

1. Draw the expected waveform of each circuit labeling each significant point (peaks and DC level).
2. Run the simulation. For Circuit A, double-click on the LabVIEW Signal Analyzer and chose *time domain signal* as its Analysis Type. For Circuit B, double-click on the Oscilloscope to view your signal. Verify your expected output from question 1.

3. Select *auto power spectrum* from the LabVIEW Signal Analyzer of circuit A. You are viewing the dB value versus the frequency or the “spectrum” on the window. Verify that the frequency of the signal shown is the same as the input of the Clamper. You can move the display vertically or horizontally in either direction in order to view a different portion of the window. To do this, select the hand in the lower right corner and move it over the window while left-clicking.
4. Change the frequency of the LabVIEW Generator to 500Hz in circuit B and repeat questions 1 and 2.

Worksheet 3-4: Bridge Rectifier and Zener Diode

Name: _____ ID Number: _____ Class: _____

Starting Point

Open the file **BridgeRectifierWFilter.ms10**.

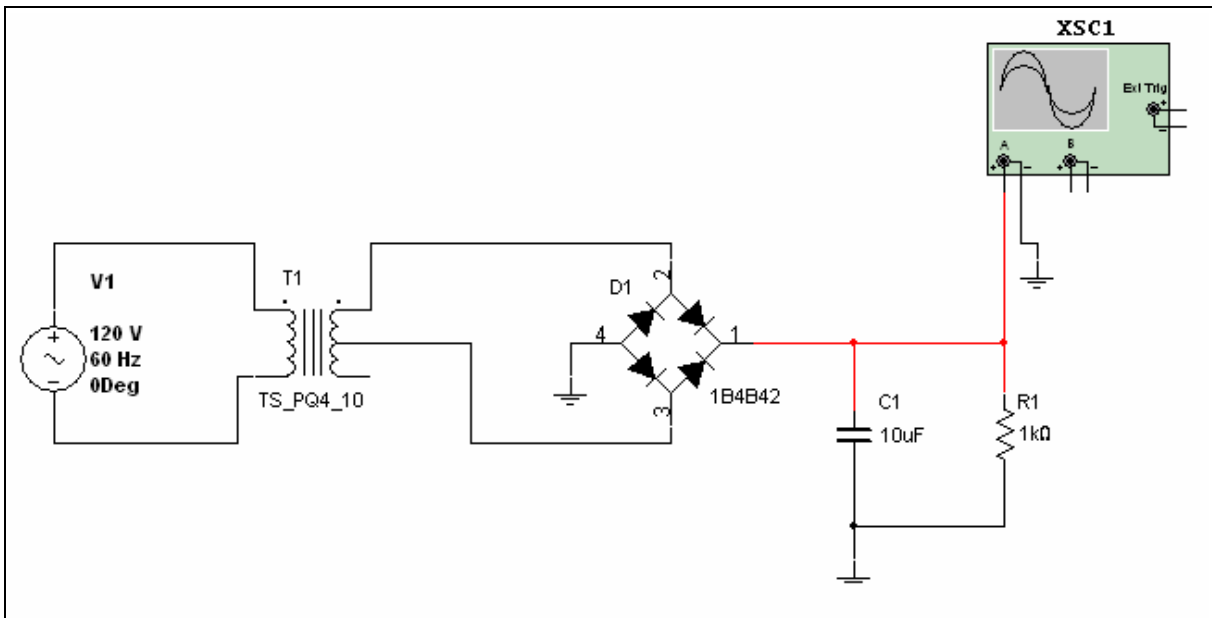

Questions

1. Analyze the circuit using your rectifier theory.
2. Draw the expected output of the filter labeling each significant point.

3. Run the simulations and compare your results to step 2.

4. Open the file **Zener.ms10**.

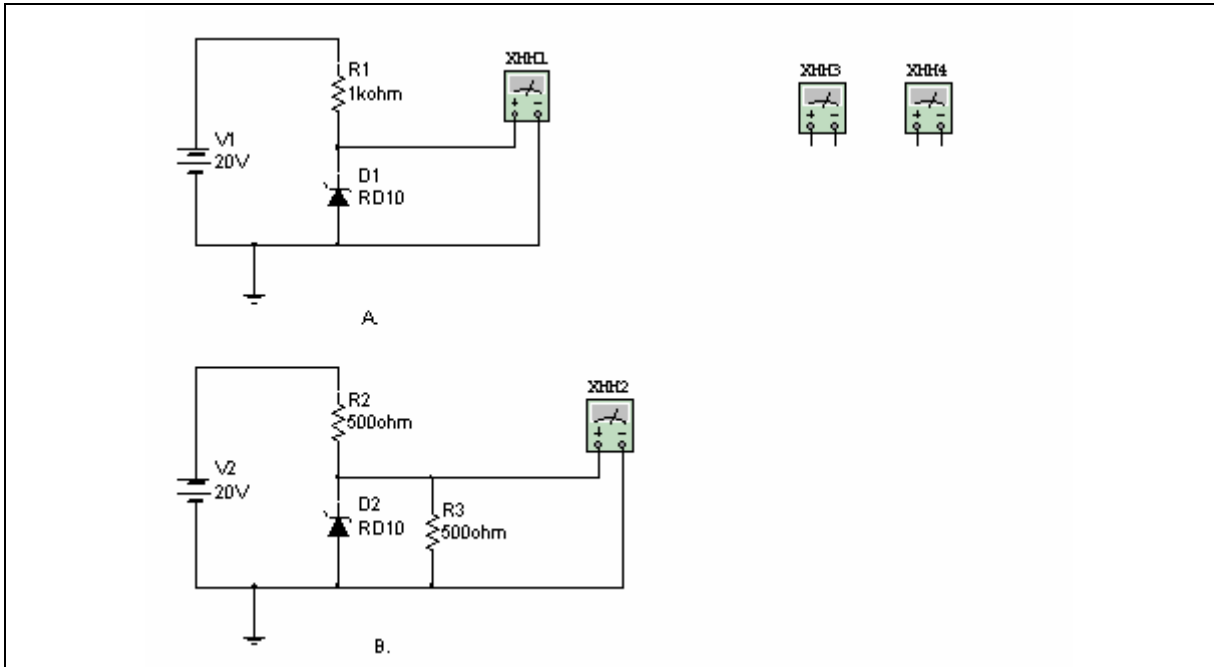

5. Given that $V_z = 10\text{ V}$, check to see whether each zener is operating above or below the knee.

$V_{o1} =$

$V_{o2} =$

6. Replace the parallel resistor in part B with a 200 ohm resistor by double-clicking on the resistor and changing its value. Re-calculate to determine if the zener is operating above or below the knee.

$V_{o2} =$

Worksheet 3-5: IV Curve

Name: _____ ID Number: _____ Class: _____

Starting Point

Open the file **IV.ms10**.

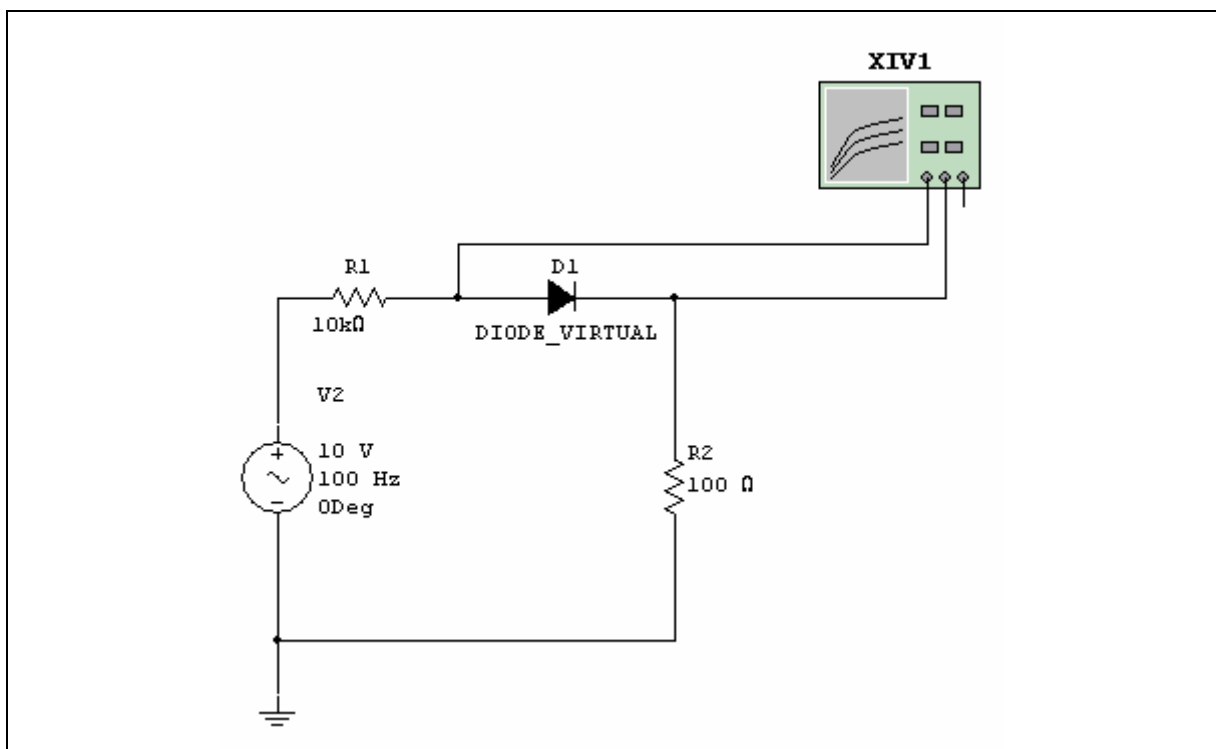

Questions

1. Draw the expected diode curve from your theory.

- Open the Oscilloscope by double-clicking on it. Run the simulation by pressing the switch to the right of the task bar or selecting **Simulate/Run** from the menu. You are now observing the characteristics of a silicon diode.
- Press the red arrow key at the bottom of the window until the blue vertical marker appears. Drag the marker to the point where the diode begins to conduct. Note the voltage found at the bottom left of the window. $V_f = \underline{\hspace{2cm}}$
- Given that $\Delta R_f = \Delta V / \Delta I$ or $V_1 - V_2 / I_1 - I_2$, measure the voltage and current at any two points along the curve to calculate R_f . Use the voltage and current values shown at the bottom of the window.

Transducer

Goal

To familiarize the student with two of Multisim's transducers. The characteristics of both an LED and a temperature-controlled resistor are examined.

Comments

Transducers can be found in the Misc parts group, Transducers family.

Procedure

- Open **Transducer.ms10**.

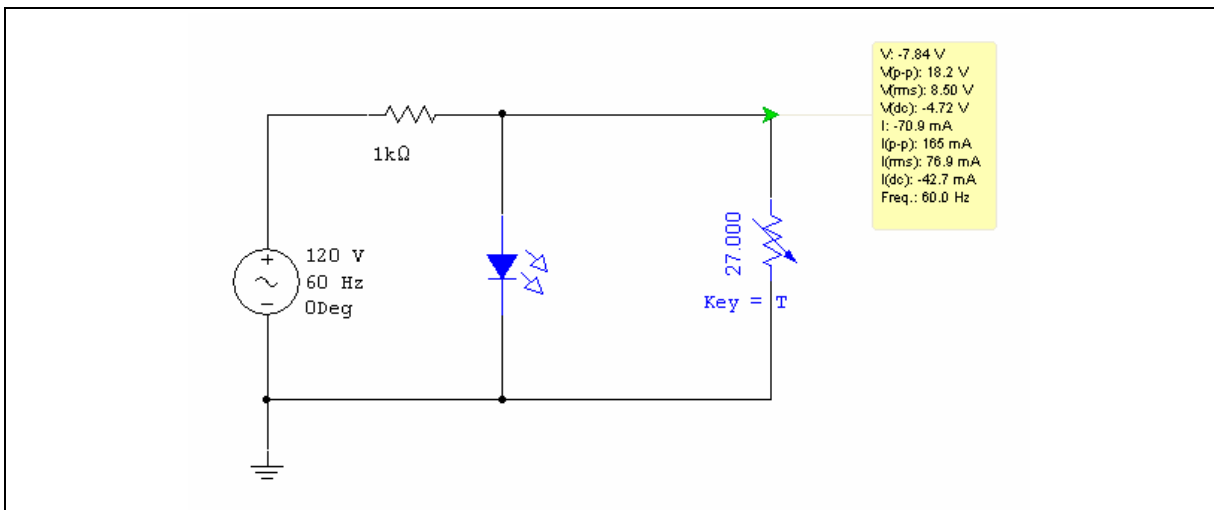

- Open the Description Box and complete the steps.
- Run the simulations by clicking on the switch or selecting **Simulate/Run** or clicking the switch.

Additional Challenge

Three circuit files contain faults and are denoted with the letters “TS”. These faults may be observed by de-selecting the **Hide component faults** checkbox found under **Options/Circuit Restrictions/General tab**, then double-clicking on the components and sources. Providing a password will prevent student access. The use of Description Boxes is intended to guide the student through the troubleshooting process.

The troubleshooting files are **Clamper1TS.ms10**, **Clipper1TS.ms10** and **ZenerTS.ms10**.

NI ELVIS Exercise

Starting Point

On your NI ELVIS breadboard, create the diode circuit that you simulated and studied in the **IV.ms10** file. The image below is an example implementation. Open **IV.ms10** and run the simulations so you have a useful reference and a better idea of how the circuit functions.

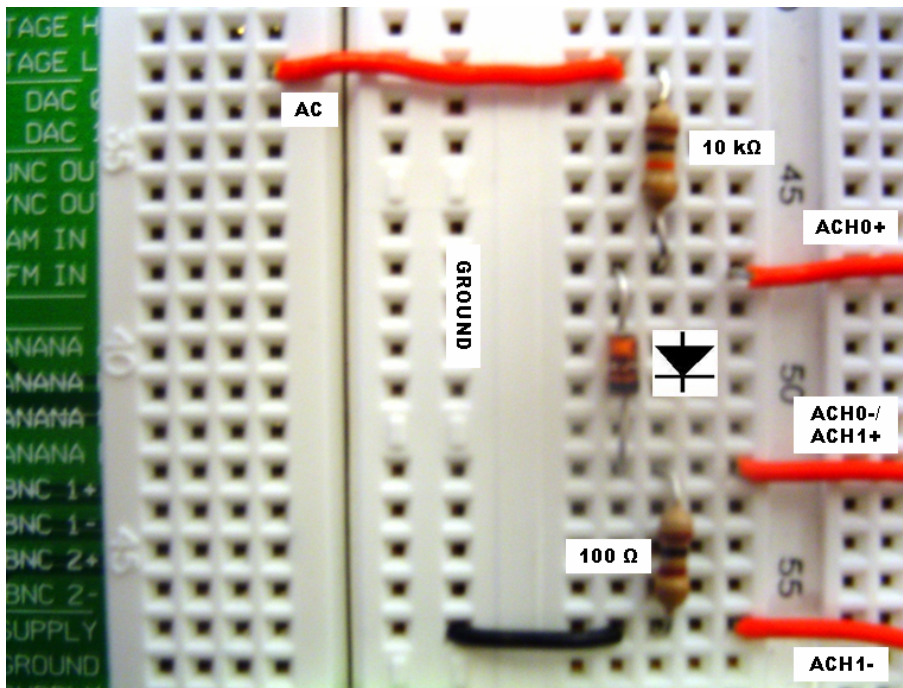

Analog output 0 (DAC 0) is used in the circuit above to generate the AC input signal. ACH0 is used to measure the voltage across the diode while ACH1 is used to measure the current through the diode.

Questions

1. Analyze the circuit above using the diode theory you have learned in class.
2. Compare your physical results using NI ELVIS with the simulated circuit outputs.

Section 4: Transistors

Section Contents

This section contains the following:

- “Introducing Bipolar Transistors” on page 4-2
- “FET Characteristics: Drain and Transconductance” on page 4-4.

Worksheets in this Section

The worksheets in this section begin on page 1 of Worksheet 4-1: Common Base Circuit:

- “Worksheet 4-1: Common Base Circuit”
- “Worksheet 4-2: Emitter Follower”
- “Worksheet 4-3: Common Emitter with an Unbypassed Resistor”
- “Worksheet 4-4: Two-Stage Transistor Amplifier”
- “Worksheet 4-5: Measuring JFET Characteristics”
- “Worksheet 4-6: Dynamic Measurement of JFET Characteristics”
- “Worksheet 4-7: Dynamic Measurement of JFET Transconductance”.
- “Worksheet 4-8: BJT CE Wizard”
- “Worksheet 4-9: BJT 2 Stage Wizard”

Circuits for this Section

The following is a list of the file names of circuits used in this section and a brief description of each.

File (.ms10)	Description
CommonBase	Investigation of the characteristics of a common base circuit.
CommonCollector	Investigation of the characteristics of an emitter follower including impedance properties.
CommonEmitter	Investigation of the properties of a common emitter circuit.
CommonEmitterTS, TSA, TSB	Faulted common emitter circuits.
FETCurve1	Measuring and plotting the drain characteristics of a JFET on a point-by-point basis.
FETCurve2	Dynamic display of JFET drain characteristic curves on an Oscilloscope.
FETTransconductance	Dynamic display of JFET Transconductance curves on an Oscilloscope.
TwoStageAmplifier	Investigation of a two-stage transistor amplifier. Gain, operating voltages and maximum undistorted output are studied, using Multisim’s Off Page Connector feature so that each stage can be analyzed on a separate page.

Introducing Bipolar Transistors

This section contains circuit files and worksheets for both bipolar junction transistors (BJTs) and field effect transistors (FETs). Emphasis will be placed on analysis of the various circuits and how they compare with simulated values. Students will be encouraged to take various measurements around the circuit. A Common Emitter with an unbypassed resistor at the emitter is included for the student to discover the trade-off between gain and impedance through experimentation.

A two-stage amplifier is also provided along with its associated worksheet, which is stored in the Description Box and can be printed out. A faulted circuit is also available.

Prerequisites

It is assumed that students know how to solve transistor circuits including AC and DC analysis and impedance characteristics.

Comments

- Use the Multimeters provided to take any appropriate voltage or current measurements. Double-click on the meter to open its window.
- Double-click on the AC supply to increase its voltage.

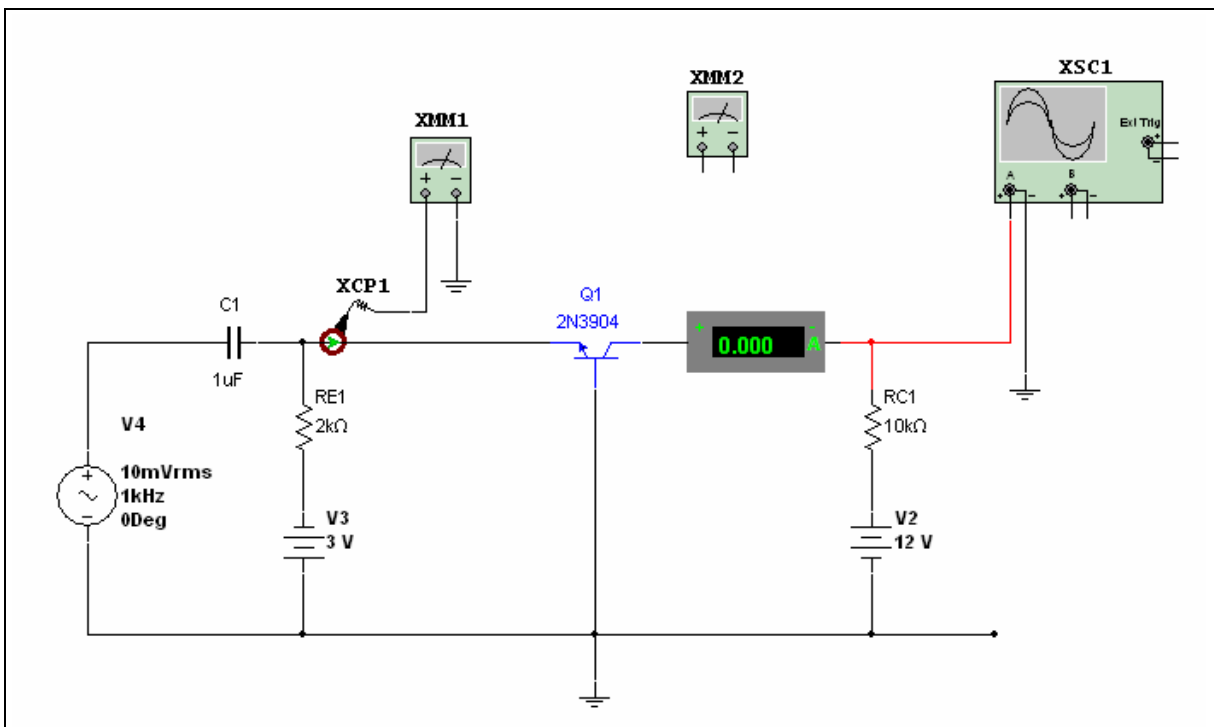

Figure 4-1: CommonBase.ms10

Relevant Worksheets

- “Worksheet 4-1: Common Base Circuit”
- “Worksheet 4-2: Emitter Follower”
- “Worksheet 4-3: Common Emitter with an Unbypassed Resistor”.
- “Worksheet 4-4: Two Stage Amplifier”.

Extension Ideas

1. The two-stage amplifier is used for troubleshooting in Section 5.
2. Files **FETCurve1.ms10**, **FETCurve2.ms10** and **FETTransconductance.ms10** illustrate how Multisim may be used to plot characteristic curves for a JFET.
3. **FETCurve1.ms10** illustrates a method of manually plotting (point-by-point) a series of drain characteristic curves for a JFET.
4. **FETCurve2.ms10** illustrates the use of an Oscilloscope to plot a dynamic curve of drain characteristic curves.
5. **FETTransconductance.ms10** illustrates the use of an Oscilloscope to plot a dynamic curve of transconductance for a JFET.
6. The principles illustrated in these three files may be expanded to almost any other active device.

FET Characteristics: Drain and Transconductance

Goal

To gain an understanding of the operation of field effect transistors.

Prerequisites

You will need the following circuit files:

- **FETCurve1.ms10**
- **FETCurve2.ms10**
- **FETTransconductance.ms10.**

Comments

For these exercises you can substitute any other FET. You can also change FET characteristics in the Edit Model window.

Relevant Worksheets

- “Worksheet 4-5: Measuring JFET Characteristics”
- “Worksheet 4-6: Dynamic Measurement of JFET Characteristics”
- “Worksheet 4-7: Dynamic Measurement of JFET Transconductance”.

Additional Challenge

Three circuit files contain faults and are denoted with the letters “TS”. These faults may be observed by de-selecting the **Hide component faults** checkbox found under **Options/Circuit Restrictions/General tab**, then double-clicking on the components and sources. Providing a password will prohibit students from accessing which component is faulted. Description Boxes guide the student through the troubleshooting process. Promoting problem-solving logic is further encouraged in the next section.

The troubleshooting files are **CommonEmitterTS.ms10**, **CommonEmitterTSA.ms10** and **CommonEmitterTSB.ms10**.

Worksheet 4-1: Common Base Circuit

Name: _____ ID Number: _____ Class: _____

Starting Point

Open file **CommonBase.ms10**.

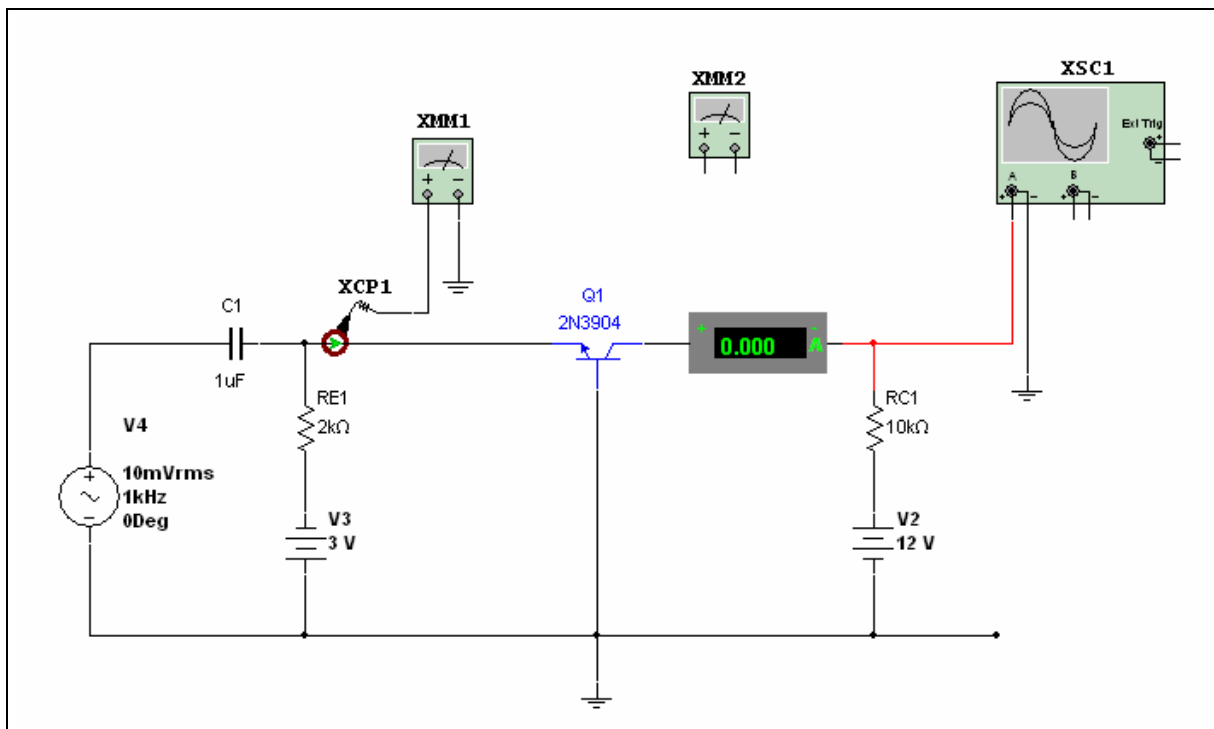

Notes

- Use the multimeters provided to take any appropriate voltage or current measurements
- Double-click on the meter to open its window.

Questions

1. Calculate I_E .
2. Calculate I_C using an alpha of 0.95.
3. Calculate the voltage across R_C , V_{RC} .
4. Calculate V_C .
5. Run the simulation and compare steps 1 through 4 using the multimeters.

The current probe behaves like a simulated clamp-on current probe that converts the current flowing through a wire to a voltage at the output of the probe. In this Common Base circuit, the output of the probe has been connected to the multimeter. To use, set the multimeter to V , then read the output in Amperes with a $1V/mA$ conversion ratio.

IE =

IC =

VRC =

VC =

6. Observe the output waveform. What is the voltage gain? What do you expect the voltage gain to be? Remember that Common Base circuit configurations are utilized for their high voltage gains.

$A_v =$

7. Calculate the maximum input voltage without clipping. Change the input voltage to represent this voltage then run the simulation to check your results.

NI ELVIS Exercise

Starting Point

Build the circuit shown in **CommonBase.ms10** on your NI ELVIS breadboard. If you do not have a particular resistor, capacitor, or voltage source, modify the file to reflect values you have available. For example, the +12 V source can be replaced with the +15 V DC Power Supply. The -3 V source can be supplied by the Variable Power Supply, and the AC source supplied by the Function Generator.

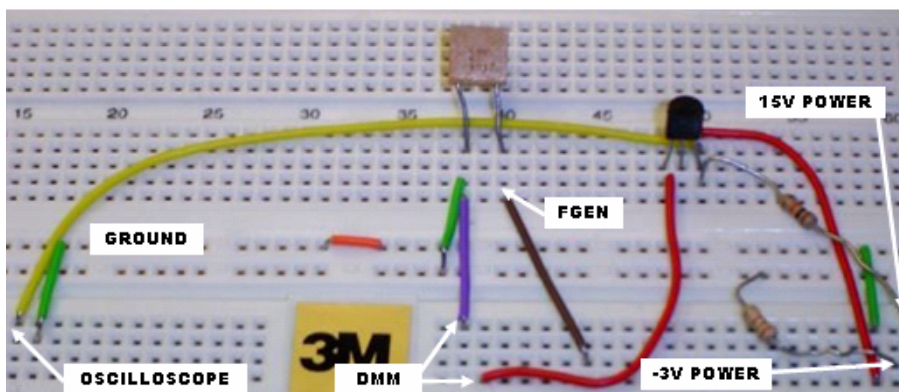

Notes

- Be sure to use the current inputs of the NI ELVIS DMM. You can only use one DMM in your circuit at a time.

Questions

1. How do your simulated values compare with values you have measured using your DMM and Oscilloscope on the NI ELVIS?

Worksheet 4-2: Emitter Follower

Name: _____ ID Number: _____ Class: _____

Starting Point

Open the file **CommonCollector.ms10**.

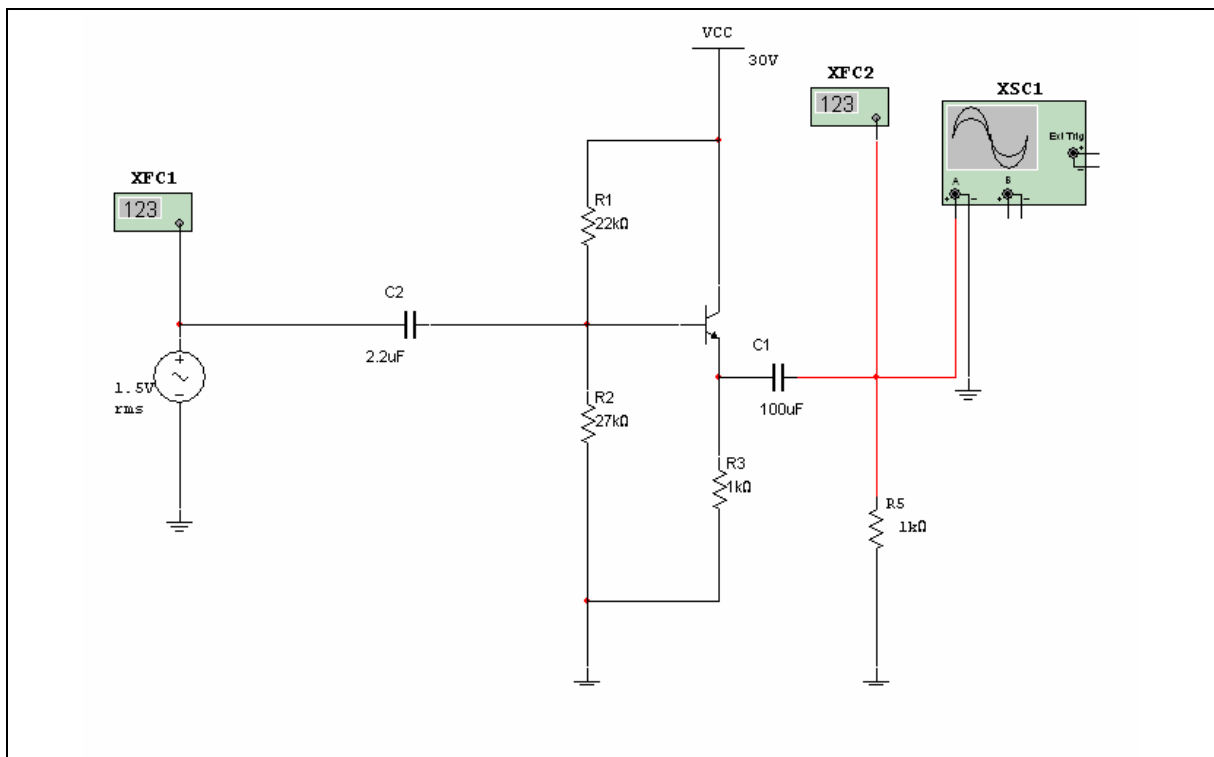

Notes

- Use the multimeters provided to take any appropriate voltage or current measurements
- Double-click on the meter to open its window
- Double-click on the AC supply to increase its voltage.

Questions

1. Do you expect a gain or attenuation with this circuit?
2. What desirable characteristics does this circuit exhibit?
3. Calculate the base current given that $\beta = 100$.
4. Calculate the emitter current.
5. Calculate the voltage at the emitter.

- Open the Frequency Counter at the input by double-clicking on it and note the frequency of operation.

Do you expect the frequency at the output of the amplifier to change or to remain the same?

Check your results with the output Frequency Counter.

- Calculate A_v .
- Run the simulation and compare your results using the multimeters and the Oscilloscope provided.

NI ELVIS Exercise

Starting Point

Create the circuit simulated in **CommonCollector.ms10** on your NI ELVIS breadboard, using the Function Generator for your AC source. There is no explicit Frequency Counter on the ELVIS, but the Oscilloscope provides a frequency measurement.

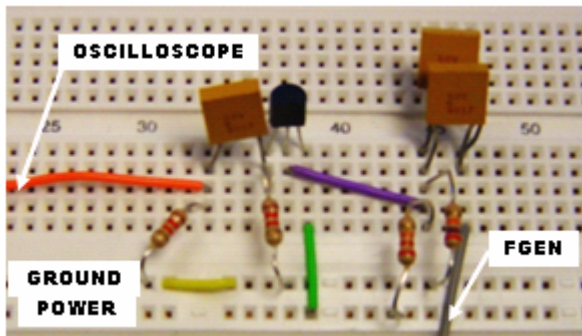

Notes

- When using the NI ELVIS Function Generator for the AC Source, recall the relationship between V_{rms} and the amplitude of a sine wave, $V_{\text{rms}} = 1/\sqrt{2} A$. The NI ELVIS Function Generator soft front panel uses amplitude to specify the magnitude of the sine wave, but the MultiSim circuit uses V_{rms} .
- In the picture, two $1 \mu\text{F}$ capacitors have been used for the $2 \mu\text{F}$ capacitor.

Questions

1. Run the simulated circuit and compare the oscilloscope measurements with the NI ELVIS Oscilloscope measurements. How do the frequency and amplitude compare?

Worksheet 4-3: Common Emitter with an Unbypassed Resistor

Name: _____ ID Number: _____ Class: _____

Starting Point

Open the file **CommonEmitter.ms10**.

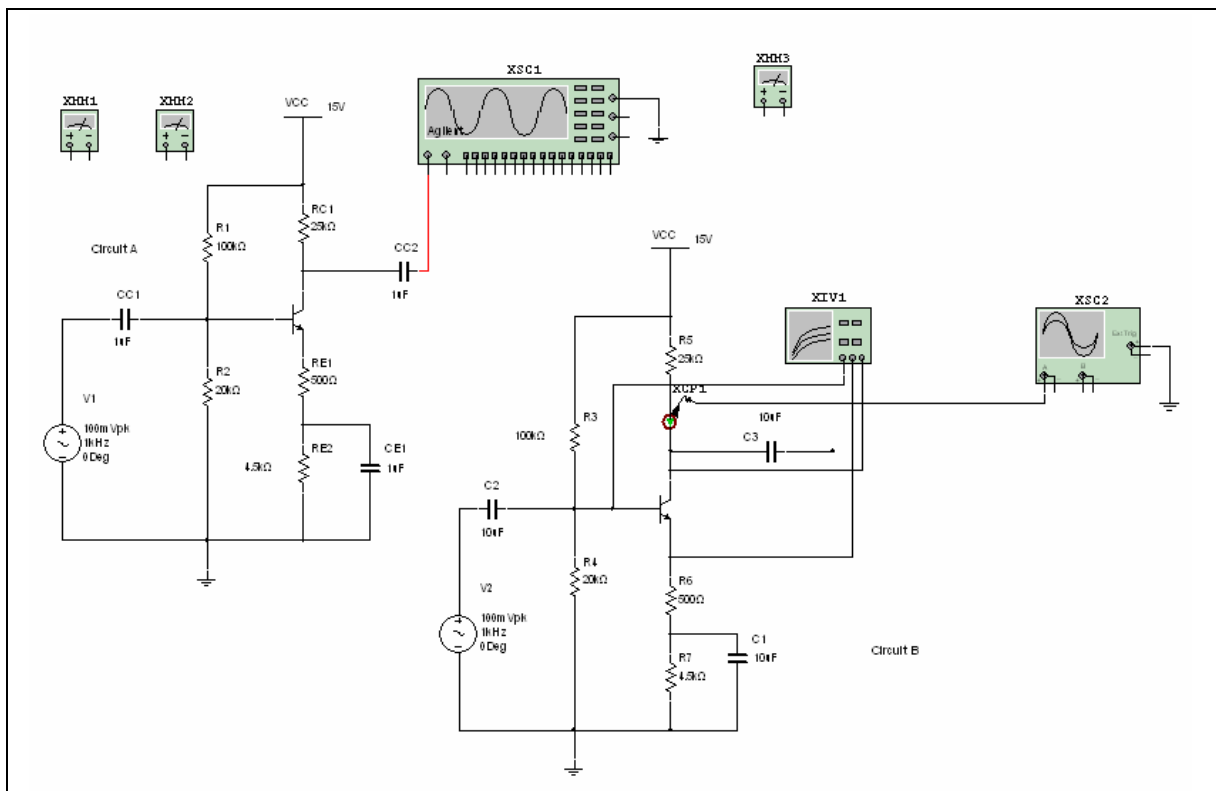

11. Use the current probe to find I_C . The current probe acts like a clamp-on current probe that converts the current flowing through a wire to a voltage at the output of the probe. The output of the probe is connected to the Oscilloscope. Read the dc voltage level on the Oscilloscope as the current I_C with a 1V/mA ratio conversion.

NI ELVIS Exercise

Starting Point

Modify Circuit A of **CommonEmitter.ms10** to have a 2 kohm potentiometer in place of RE1.

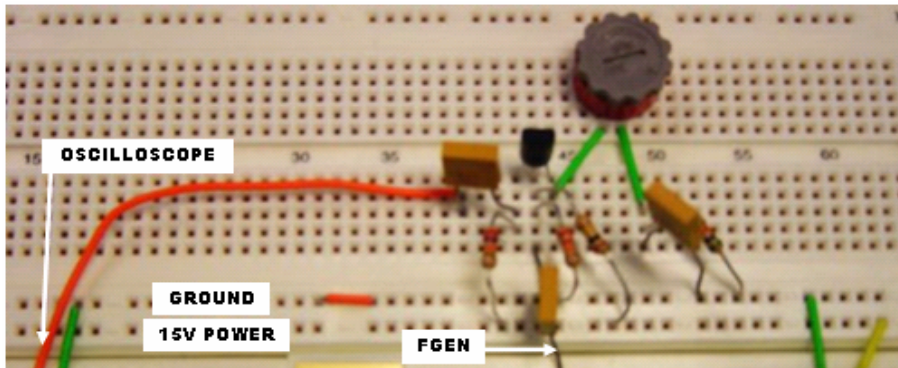

Questions

1. Run the simulation, and vary the resistance of the potentiometer. Use the oscilloscope to view the saturation you observed when shorting resistor RE1 previously. On NI ELVIS, build the same circuit and use the NI ELVIS Oscilloscope to view the output while varying the potentiometer. Compare the simulation to the circuit.
2. Do you see a relationship between the unbypassed emitter resistor value and voltage gain? Does it match the relationship found in question 8 above?

Worksheet 4-4: Two-Stage Transistor Amplifier

Name: _____ ID Number: _____ Class: _____

Starting Point

Open file **TwoStageAmplifier.ms10**.

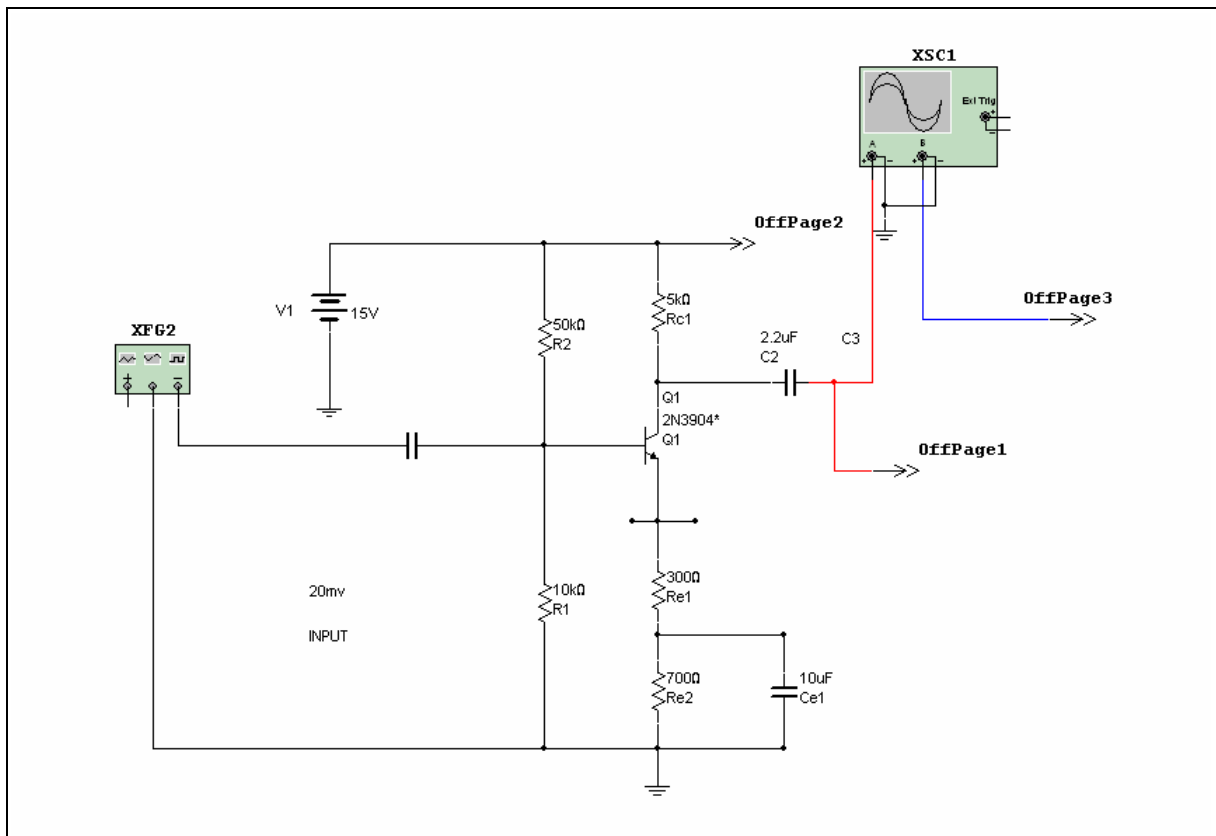

Two files will open. One file will contain the first stage along with several questions in the Description Box, and the second file will contain the second stage. An Off Page Connector will connect the two stages.

Notes

This exercise illustrates how to use the “three step” learning approach with more complex circuits. It reinforces the importance of correlating theory, software simulation and “real world” results, including discrepancies between theory and real components with tolerances.

Students should have the background to completely analyze multi-stage transistor amplifiers, including DC bias, AC input impedance, and voltage gain (and possibly frequency response).

This circuit is repeated in Section 5 with a fault introduced to provide further realistic training in troubleshooting where theory alone may not be sufficient to solve the problems.

Questions

Measure the following operating characteristics of this amplifier. Indicate what measurements were made and show any calculations. A worksheet similar to this procedure is included with the circuit.

1. Determine the output voltage for 20 mV(p-p) input:

$$V_{out} = V(p-p) \text{ or } V(RMS)$$

2. Measure the voltage gain of the amplifier:

As a ratio: Voltage gain =

Expressed in decibel notation:

Voltage gain =

3. What is the input amplitude at which the output just begins to distort (clip)?

4. Find the maximum allowable input for no distortion.

Worksheet 4-5: Measuring JFET Characteristics

Name: _____ ID Number: _____ Class: _____

Starting Point

Open file **FETCurve1.ms10**.

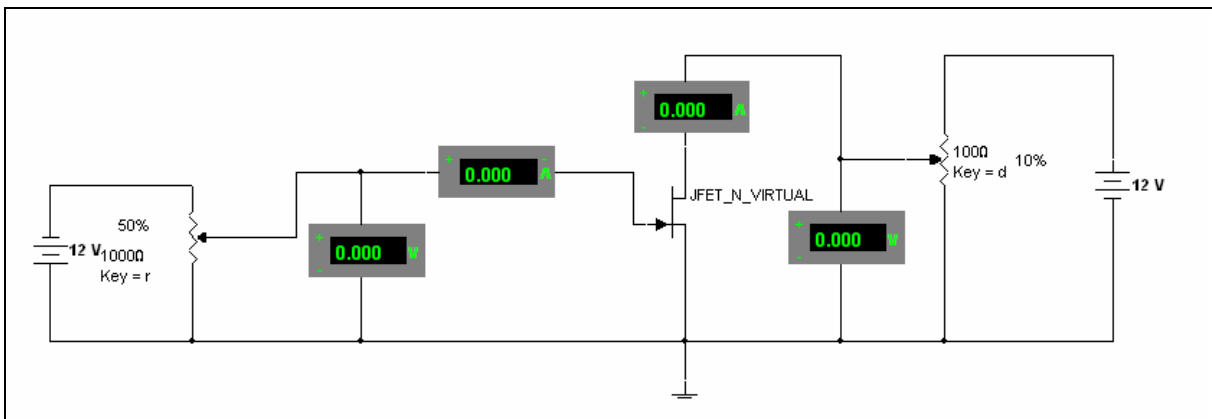

Notes

The two potentiometers are included to facilitate changing the gate bias voltage V_{gs} and the drain to source voltage V_{ds} .

- Pressing R increases gate to source bias (in the negative direction) and pressing SHIFT-R decreases V_{gs} toward 0 V. You can also hover your cursor over a potentiometer and drag the slider bar that appears
- Pressing D decreases V_{ds} and SHIFT-D increases it
- Exact voltages may not be available within the potentiometer settings. A few millivolts will make no significant difference to results.

Questions

1. Plot the drain characteristic curves:

a) $I_{dss} = \underline{\hspace{2cm}}$ mA

b) Note the Gate current I_g . $I_g =$

Is it significant or could it be approximated to zero?

2. Set V_{gs} to 0 V, V_{ds} to 12 V and measure the drain current. Discuss the characteristics that would involve choosing a FET instead of a BJT. Talk about the Common Emitter with unbypassed resistance and the Emitter Follower configuration in your discussion.

3. For each value of V_{gs} in the tables below, set V_{ds} to the given value and measure and record drain current I_d .

$V_{gs} = -6$

V_{ds}	1.0 V	2.0 V	3.0 V	5.0 V	9.0 V	12.0 V
I_d						

$V_{gs} = -4$

V_{ds}	1.0 V	2.0 V	3.0 V	5.0 V	9.0 V	12.0 V
I_d						

$V_{gs} = -2$

V_{ds}	1.0 V	2.0 V	3.0 V	5.0 V	9.0 V	12.0 V
I_d						

$V_{gs} = -1$

V_{ds}	1.0 V	2.0 V	3.0 V	5.0 V	9.0 V	12.0 V
I_d						

$V_{gs} = 0$

V_{ds}	1.0 V	2.0 V	3.0 V	5.0 V	9.0 V	12.0 V
I_d						

Worksheet 4-6: Dynamic Measurement of JFET Characteristics

Name: _____ ID Number: _____ Class: _____

Starting Point

Open file **FETCurve2.ms10**.

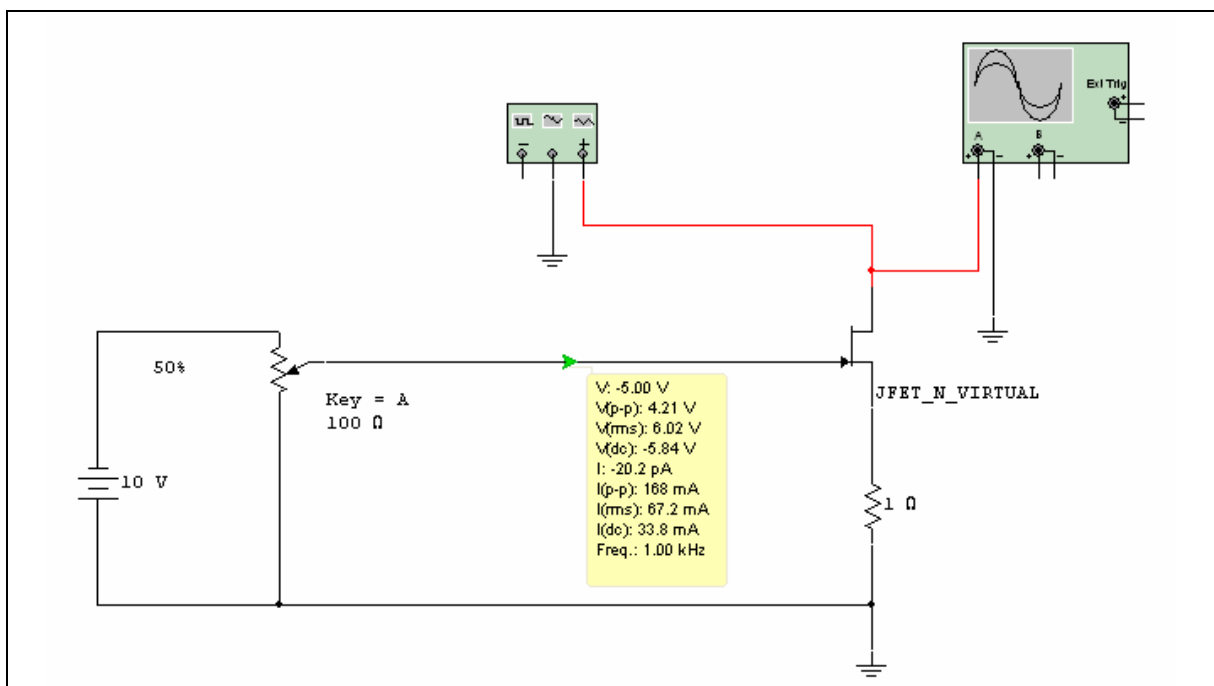

Notes

- The potentiometer allows the gate bias voltage V_{gs} to be changed. Pressing the R key increases the gate to source bias (in the negative direction) and pressing SHIFT-R decreases V_{gs} toward 0 V. You can also hover your cursor over a potentiometer and drag the slider bar that appears.
- Exact voltages may not be available within the potentiometer settings. A few millivolts will make no significant difference to results
- The curve is plotted with drain voltage applied to the horizontal axis and drain current, sensed by voltage across the 1 ohm resistor, on the vertical axis. (Current sensitivity is 1 mA for each millivolt across the 1 ohm resistor.) A curve is plotted for each value of V_{gs} .

Questions

1. Plot the dynamic drain characteristic curves:
 - a) Set V_{gs} to zero and V_{ds} to 12 V. Observe the drain characteristic curve for this value of V_{gs} . Comment on the shape of the curve compared to typical curves from a text or from results plotted from file **FETCurve1.ms10**.

 - b) Change V_{gs} and repeat the measurement. If you have measured values from **FETCurve1.ms10**, compare specific points on this dynamic curve and the plotted curve.

2. Write a brief report on the results of this investigation.

NI ELVIS Exercise

Starting Point

Build the circuit found in **FETCurve2.ms10** on your NI ELVIS breadboard. Inputs to the circuit are from the variable power supply and the function generator. The output is connected to both channels of the oscilloscope.

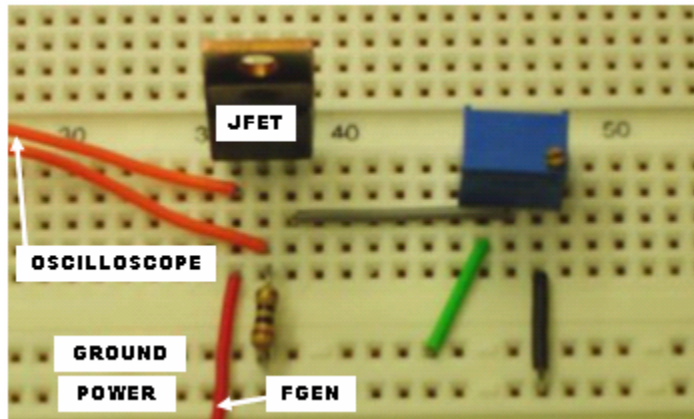

Notes

- The NI ELVIS function generator has a maximum of 2.5 Vpp.

Questions

1. While observing both channels of the NI ELVIS oscilloscope, change V_{gs} using the potentiometer. Describe how your observations compare to the simulation results.
2. Use the two-wire current voltage analyzer on NI ELVIS to plot the drain characteristic curves. To do this, you will need to disconnect your circuit from the oscilloscope and function generator. Connect the transistor drain to the current hi input of the DMM and the transistor source to the current lo. For more information on these connections, see the NI ELVIS help. Compare the result to the curve plotted in Multisim.

Worksheet 4-7: Dynamic Measurement of JFET Transconductance

Name: _____ ID Number: _____ Class: _____

Starting Point

Open file **FETTransconductance.ms10**.

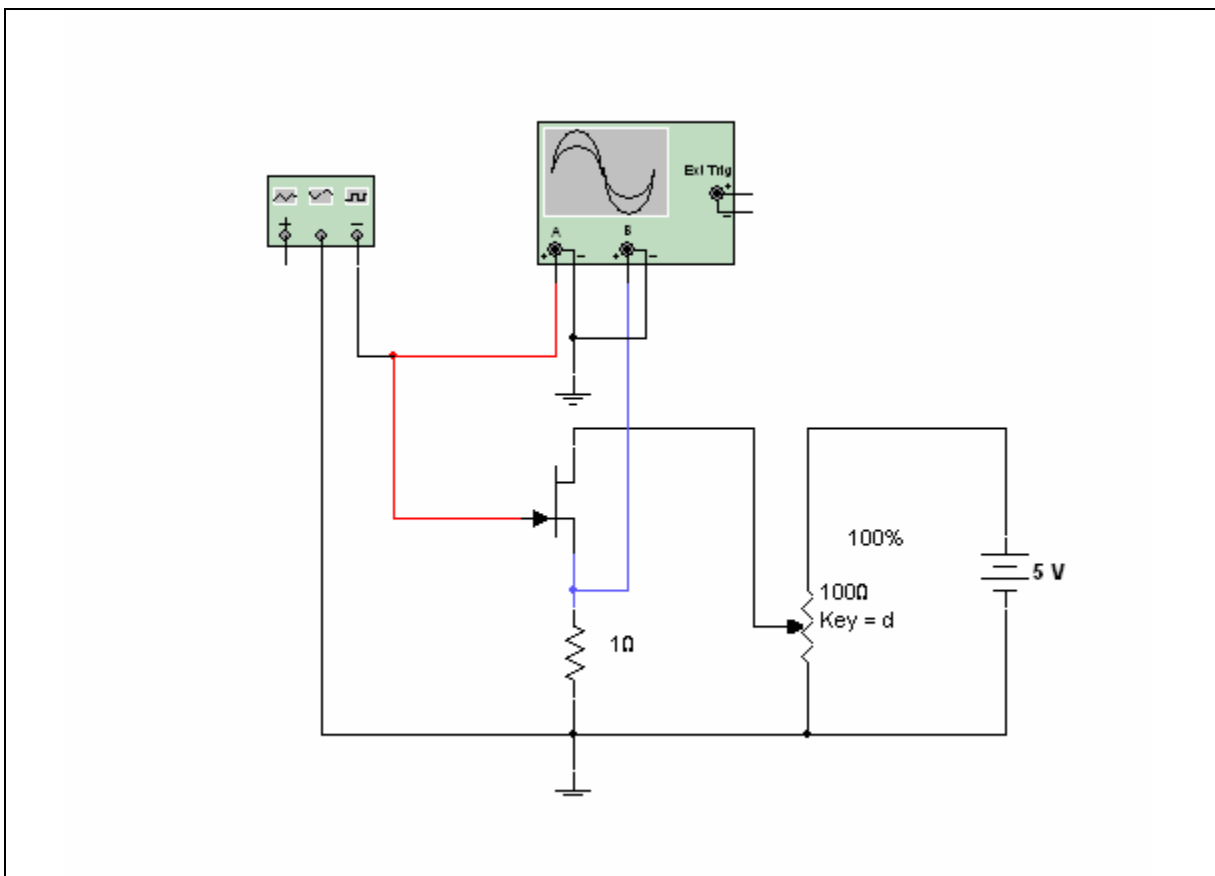

Notes

- The potentiometer allows the drain source voltage V_{ds} to be changed. Pressing the D key increases the gate to source bias (in the negative direction) and pressing SHIFT-D decreases V_{ds} toward 0 V. You can also hover your cursor over a potentiometer and drag the slider bar that appears.
- Exact voltages may not be available within the potentiometer settings. A few millivolts will make no significant difference to results
- The curve is plotted with gate source voltage (V_{gs}) applied to the horizontal axis and drain current, sensed by voltage across the 1 ohm resistor, on the vertical axis. (Current sensitivity is 1 mA for each millivolt across the 1 ohm resistor.) A curve is plotted for each value of V_{ds} .

Questions

1. Plot the dynamic Transconductance characteristic curves:
 - a) Set V_{ds} to 12 V and observe the Transconductance characteristic curve for this value of V_{ds} . Comment on the shape of the curve compared to typical curves from a text or from results plotted from file **FETCurve1.ms10**.

 - b) Comment on the value of I_{dss} from this curve compared to a value obtained from file **FETCurve1.ms10** or **FETCurve2.ms10**.

 - c) Change V_{ds} and repeat the measurement. If you have measured values from **FETCurve1.ms10**, compare specific points on this dynamic curve and the plotted curve.

2. Write a brief report on the results of this investigation.

NI ELVIS Exercise

Starting Point

Open **FETTransconductance.ms10** and build the circuit on your NI ELVIS breadboard. The function generator and variable power supply are inputs to your circuit, and two channels of the oscilloscope are used to compare the input of the function generator to the drain current.

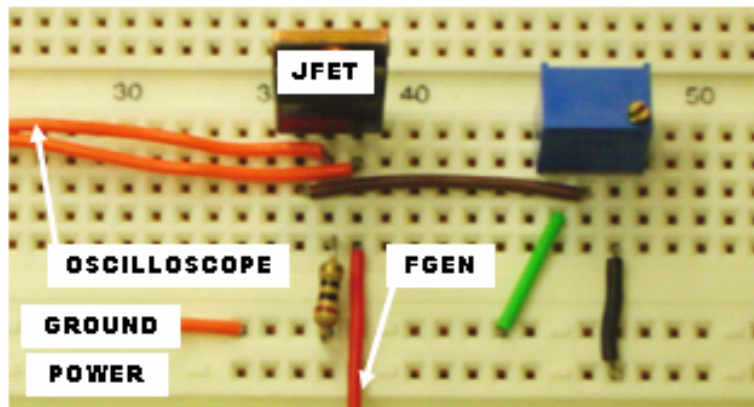

Questions

1. While observing both channels of the NI ELVIS oscilloscope, change V_{ds} using the potentiometer. Describe how your observations compare to the simulation results.
2. Use the two-wire current voltage analyzer on the NI ELVIS to plot the drain characteristic curves. To do this, you will need to disconnect your circuit from the oscilloscope and function generator. Connect the transistor gate to the current hi input of the DMM and the transistor source to the current lo. For more information on these connections, see the NI ELVIS help. Compare the result to the curve plotted in Multisim.

Worksheet 4-8: BJT CE Wizard

Name: _____ ID Number: _____ Class: _____

Starting Point

Open file **BJT CE Wizard.ms10**.

Questions

1. Select **Tools/Circuit Wizards/CE BJT Amplifier Wizard**. Build a one stage amplifier with a gain of 125, VCC = 10 volts and a 1 kHz input frequency. Verify your circuit parameters then build the circuit.
2. Adjust your circuit values to real world components while keeping the gain within 10 percent of 125. Double-click on each component to change its value.
3. Comment on the limitations/strengths of your amplifier design.
4. Calculate the maximum input voltage permitted without clipping.

Worksheet 4-9: BJT 2 Stage Wizard

Name: _____ ID Number: _____ Class: _____

Starting Point

Open file **BJT 2 Stage Wizard.ms10**.

Questions

1. Select **Tools/Circuit Wizards/CE BJT Amplifier Wizard**. Build a two stage amplifier with $V_{CC} = 15$ volts and a 1 kHz input frequency. The gain of each amplifier should be 100. Use a beta of 125. Verify your circuit parameters then build each circuit.
2. Adjust your circuit values to real world components while keeping the gain within 10 percent of the required gain. Double-click on each component to change its value.
3. Comment on the limitations/strengths of your amplifier design.
4. Calculate the maximum input voltage permitted without clipping.
5. Re-calculate the maximum input voltage permitted without clipping.
6. Why would an unbypassed resistance be included in a Common Emitter design? How does it affect the circuit?

Section 5: Troubleshooting and Problem Solving

Section Contents

This section contains the following:

- “Real-World Challenges in a Simulated Environment” on page 5-3
- “Troubleshooting Activities” on page 5-4
- “Puzzles: Thinking With Knowledge” on page 5-5
- “Problem Solving Techniques” on page 5-6
- “The Bridge Between Problem Solving and Design” on page 5-8.

Trouble Shooting Activities and Worksheets in this Section

The trouble shooting activities and worksheets in this section start on page 1 of Worksheet:
Troubleshooting Activity 5-1: Series Resistance

- “Troubleshooting Activity 5-1: Series Resistance”
- “Troubleshooting Activity 5-2: DC Circuits 2”
- “Troubleshooting Activity 5-3: DC Circuits 3”
- “Troubleshooting Activity 5-4: NPN, Voltage Divider Bias”
- “Troubleshooting Activity 5-5: NPN Partial Emitter Bypass”
- “Troubleshooting Activity 5-6: Common Base Configuration”
- “Troubleshooting Activity 5-7: Troubleshooting a Two-Stage Amplifier”
- “Troubleshooting Activity 5-8 Black Box Puzzles 1 and 2”.

Circuits for this Section

The following is a list of the file names of circuits used in this section and a brief description of each.

File (.ms10)	Description
CommonBaseTS	Troubleshooting a transistor configuration in order to determine its region of operation.
Puzzle1-6	Black box problems. Determine the components in a box by measurements.
SeriesParallel2	Troubleshooting series-parallel circuits.
SeriesParallel3	Troubleshooting series-parallel circuits.
TroubleShooting1	Troubleshooting a series circuit with an ohmmeter.
TroubleShooting2	Transistor voltage divider bias problem.
TroubleShooting3	Transistor amp problem.

TroubleShooting4	Two-stage transistor amplifier (voltage divider bias, partially bypassed emitters).
Files for practice finding faults:	
GateFaults	Faults in individual IC gates.
GateFaults2	Faults in an integrated circuit.
Troubleshooting2A	Faults in an NPN voltage divider bias circuit.

Real-World Challenges in a Simulated Environment

Students have a lot to contend with when entering their first year of electronics. They must have sufficient math skills to be able to apply concepts that may be alien to them. They must learn the theoretical side of electronics and also familiarize themselves with the various instruments involved.

Students are generally introduced to troubleshooting through their own errors. This can confuse them, particularly when the basic theory involved is not yet digested. Such large blocks of time are often spent on presenting the various concepts and dealing with damaged components and equipment, that troubleshooting concepts can be brief, if presented at all. This is frustrating for both students and instructors.

Using Multisim to teach troubleshooting concepts is the perfect solution. With Multisim you can create circuits with your own faults or faults that are accessible in the program. When using Multisim's faults, you can prohibit student access to them using a password that you set.

Faults may also be hidden by creating and locking subcircuits. You can direct the student to isolate the fault through use of the Description Box. The student may then correct the fault using the components and sources available.

Voltage levels may be quickly measured through use of the Dynamic Measurement Probe. Multisim's spreadsheet feature allows the student to see all of the selected characteristics of all of the components. The student is also permitted to manipulate all such characteristics from the spreadsheet itself.

Eventually, you will notice a logical thinking process developing in your students. Aside from being an essential aspect of a student's education, troubleshooting is an area where students can gain confidence in their understanding of electronics with the natural spillover into theory.

Following this introduction are several troubleshooting exercises that will get you started. Many of them are either taken from, or are spin-offs of, circuits from the book *Troubleshooting with Electronics Workbench*, published by Electronics Workbench Corporation. The passwords have been removed from these files so that you may examine the faults introduced into the circuits. However, you should add your own passwords before using these files with your students.

Troubleshooting Activities

Goal

To give students experience in troubleshooting circuits.

Prerequisites

You will need the following:

- **TroubleShooting1.ms10 – TroubleShooting4.ms10**
- **SeriesParallel2.ms10**
- **SeriesParallel3.ms10**
- **CommonBaseTS.ms10.**

Students should have:

- Some familiarity with basic series-parallel circuits, transistor characteristics, and voltage amplifiers
- Some familiarity with characteristics of reactive circuits.

Relevant Trouble Shooting Activities

- “Troubleshooting Activity 5-1: Series Resistance”
- “Troubleshooting Activity 5-2: DC Circuits 2”
- “Troubleshooting Activity 5-3: DC Circuits 3”
- “Troubleshooting Activity 5-4: NPN, Voltage Divider Bias”
- “Troubleshooting Activity 5-5: NPN Partial Emitter Bypass”
- “Troubleshooting Activity 5-6: Common Base Configuration”
- “Troubleshooting Activity 5-7: Troubleshooting a Two-Stage Amplifier”.

Puzzles: Thinking With Knowledge

Problem Solving at its Best

Teaching electronics has traditionally incorporated problems from the textbook to enhance various electronic concepts. In many cases, the emphasis is on “number crunching” or on following some set procedure that is in the textbook or part of some laboratory procedure. Multisim gives instructors increased flexibility.

With Multisim, you can create puzzles that enhance your students' skills in interpreting readings and values obtained from circuits (or equipment) for which complete information is not available. Evaluating black box behavior requires students to select and intelligently adjust test equipment, interpret readings, apply basic theory and, most importantly, do considerable thinking and problem solving.

Like troubleshooting exercises, these may include passwords and restricted access to additional parts and models at the instructor's discretion. We have removed the passwords from the files here so that you can look inside the black boxes. However, you'll need to add your own passwords to these circuit files before using them with your class. This may be done by clicking on the Password button found under **Options/Circuit Restrictions**.

You can create new puzzles by creating and locking sub-circuits. It is an advantage with these black box puzzles if the original file is protected on a network. Students may copy the original file to their floppy, solve the puzzle, include their solution in the Description Box and return the floppy to their instructor for evaluation. Or, they can copy their solution file to another directory for later evaluation.

As students gain confidence in working with black box puzzles, it is useful to include problems that cannot be solved with the given information and/or equipment. Concepts will be solidified when the students have the confidence to tell you when a puzzle cannot be solved.

Sample Puzzles

Six sample black box puzzles are provided in circuit files **Puzzle1.ms10** through **Puzzle6.ms10**. Hints, a sample worksheet and a suggested approach to solving the puzzle are included on the following pages or in the Description Box of the file.

Problem Solving Techniques

Goal

To practice problem-solving techniques and thinking about problems.

Prerequisites

You will require circuit files **Puzzle1.ms10** and **Puzzle2.ms10**.

Students need familiarity with the behavior of RC, RL and RLC circuits, under AC conditions, including amplitude response and phase shift with frequency.

Comments

Each black box here is a sub-circuit (as described previously) and behaves as a single component. In **Puzzle1.ms10**, the black box behaves as a single capacitor and in **Puzzle2.ms10** as an inductor.

Procedure

1. Open file **Puzzle1.ms10** or **Puzzle2.ms10**.

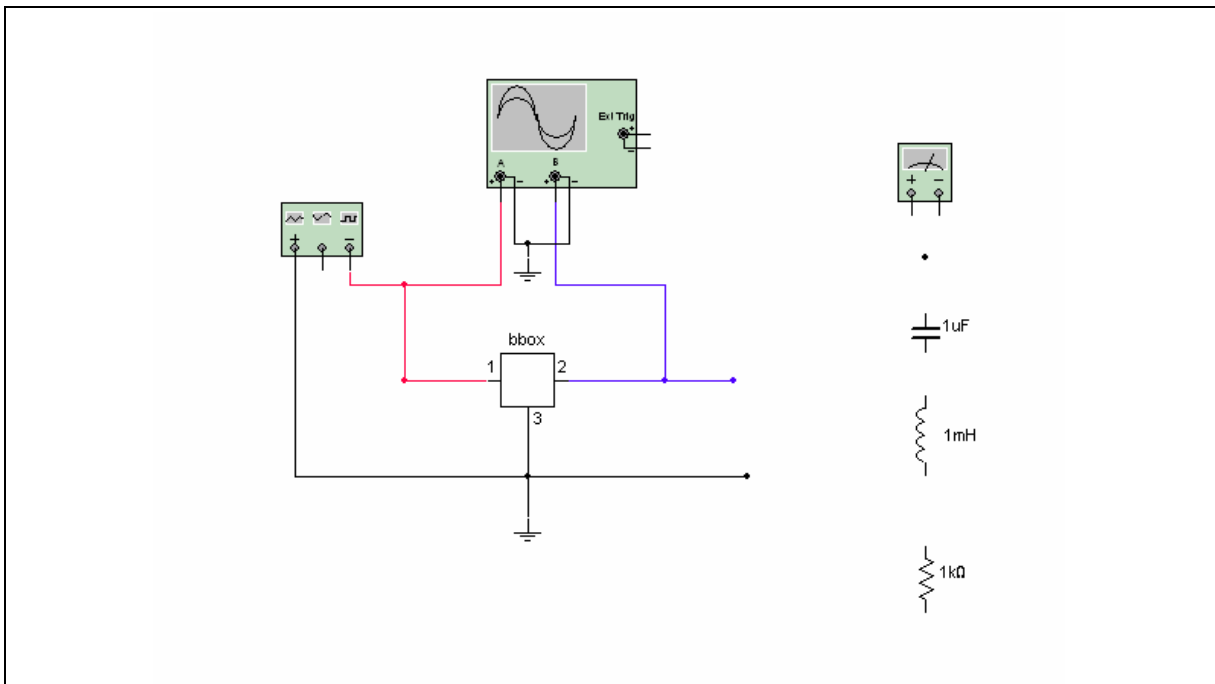

Figure 5-1: Puzzle1.ms10

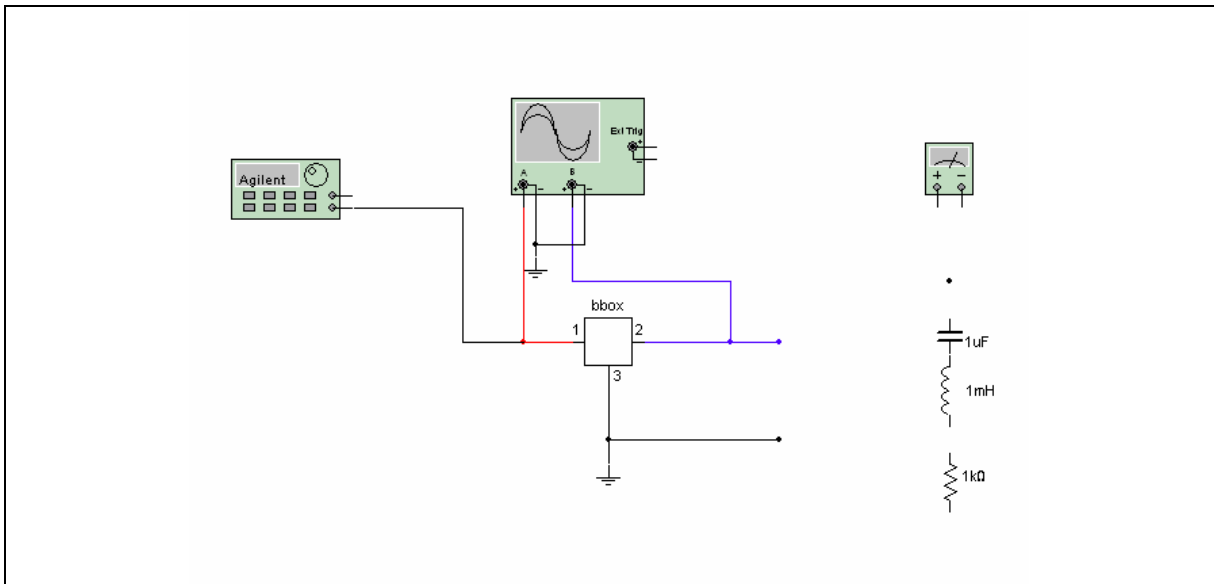

Figure 5-2: Puzzle2.ms10

2. As a class, brainstorm problem-solving strategies that could be employed. The goal here is to generate a strategy that approximates the one recommended in the “Black Box Puzzles” worksheet that follows.
3. The worksheet has been designed to work for either or both of the puzzles. Once you have elicited a problem-solving approach that is close enough, assign one of the black box puzzles to your students. Distribute copies of the worksheet, and direct them to complete it while solving the puzzle.

Relevant Worksheets

“Troubleshooting Activity 5-8 Black Box Puzzles 1 and 2”.

The Bridge Between Problem Solving and Design

Goal

To practice problem-solving techniques and thinking about problems.

Prerequisites

You will require circuit files **Puzzle3.ms10** – **Puzzle6.ms10**.

It is assumed that the student knows how to use the Function Generator and Voltmeter, including selecting AC or DC function for the Voltmeter.

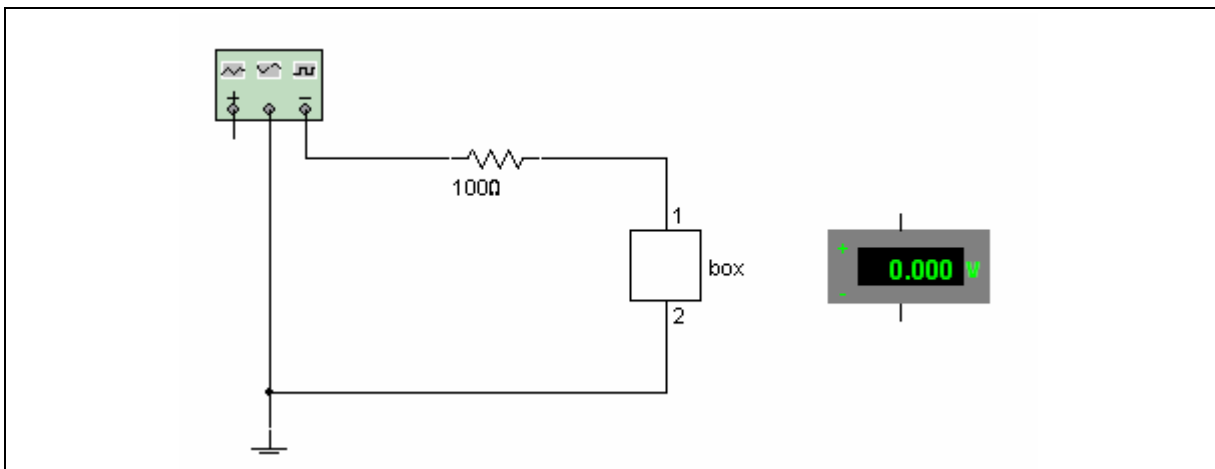

Figure 5-3: Puzzle3.ms10

Extension Ideas

In the three remaining puzzles, the students are told the contents of the box but not the configuration. They are asked to determine the configuration and then to build a circuit, using the supplied components that would behave in the same manner as the black box. Students can save puzzles to floppy disk and submit them to the instructor for evaluation.

It is suggested that you disable component access in **Puzzle4** through **Puzzle6** (see **Options/Circuit Restrictions/Toolbars**). The student can then use only the components supplied on the “breadboard”. The three puzzles are shown below.

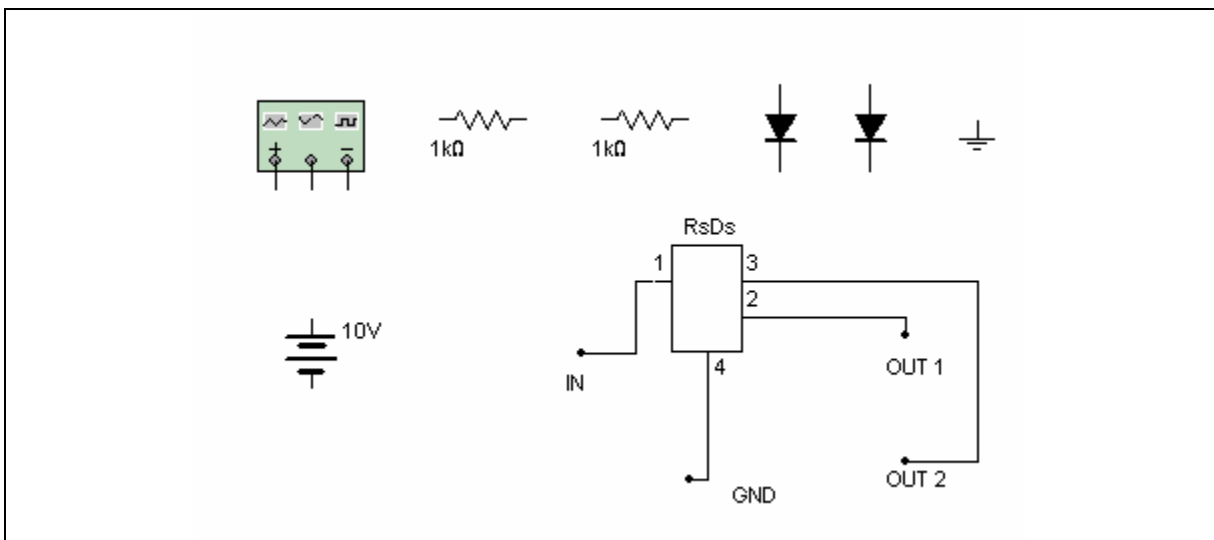

Figure 5-4: Puzzle4.ms10

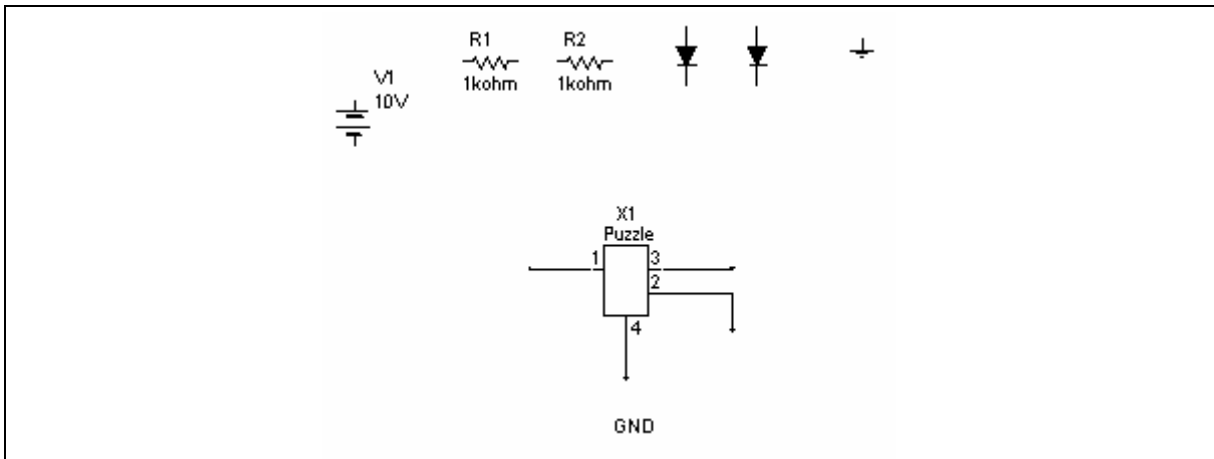

Figure 5-5: Puzzle5.ms10

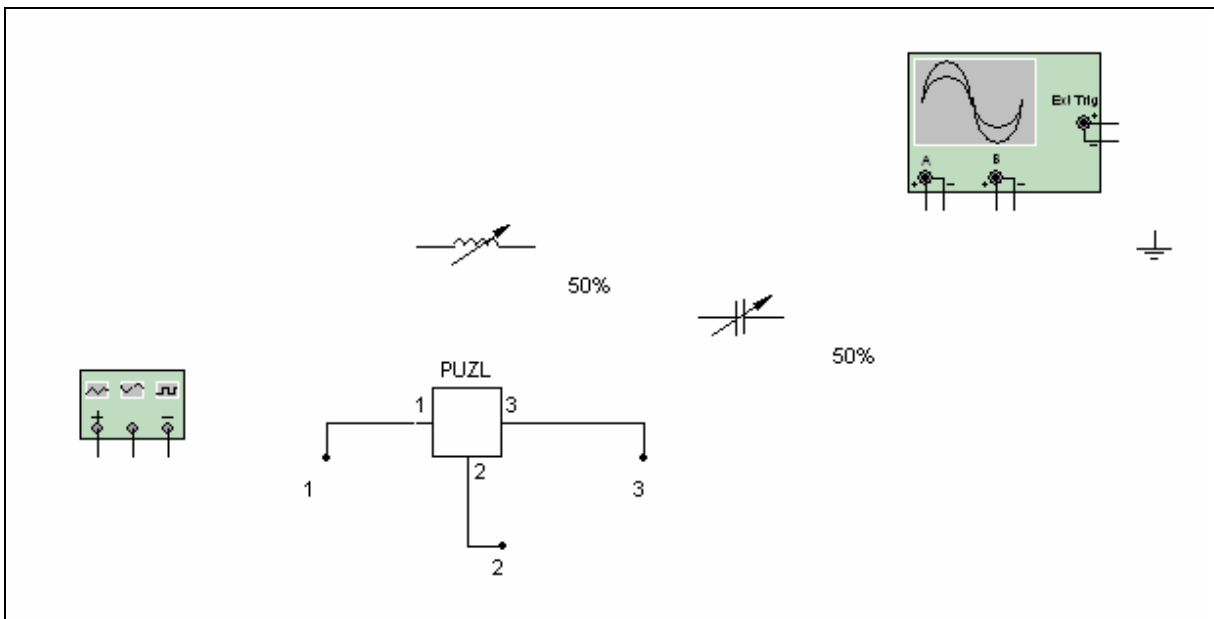

Figure 5-6: Puzzle6.ms10

References

Topic	Reference
Oscilloscope	Multisim User Guide: Ch. 8 “Instruments”
Description Box	Multisim User Guide: Ch. 2 “Schematic Capture - Basics”
Passwords	Multisim for Educators: Ch. 1 “Educators' Guide”
Restrictions	Multisim for Educators: Ch. 1 “Educators' Guide”

Troubleshooting Activity 5-1: Series Resistance

Name: _____ ID Number: _____ Class: _____

Starting Point

Open **TroubleShooting1.ms10**.

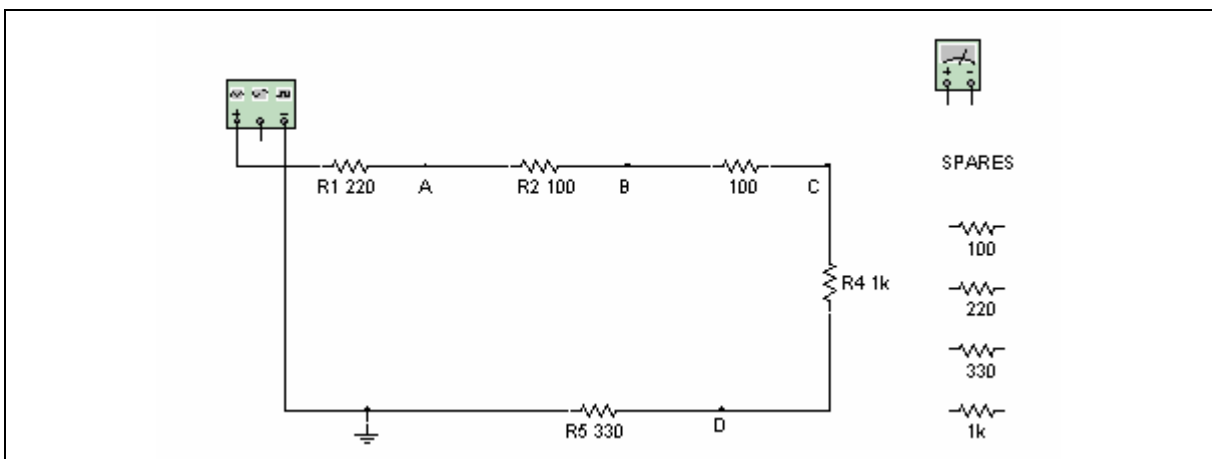

Notes

Total resistance $R_T = 1.75\text{kohm}$ (correct operation).

Suggestions

- Measure total series resistance
- Compare measured R_T with correct value
- Can the fault be determined immediately? That is, is the difference equal to any one of the values shown on the schematic? If so, check the suspect resistor (or resistors, if there are more than one of the same value.)
- If the fault is not obvious, check each resistor
- Replace the faulty resistor from the spare parts provided and check for proper circuit resistance.

Note It may not be necessary to take all readings provided for in this report. Good troubleshooting procedure means that you take only enough readings to find the fault. When you have done that, replace the faulty component from the spare parts provided and check for proper circuit operation.

Troubleshooting Report

1. Initial fault indication:
2. Readings taken to isolate the fault:

R1 =

R2 =

R3 =

R4 =

R5 =

Faulty resistor is

Repair results R_T

Troubleshooting Activity 5-2: DC Circuits 2

Name: _____ ID Number: _____ Class: _____

Starting Point

Open file **SeriesParallel2.ms10**.

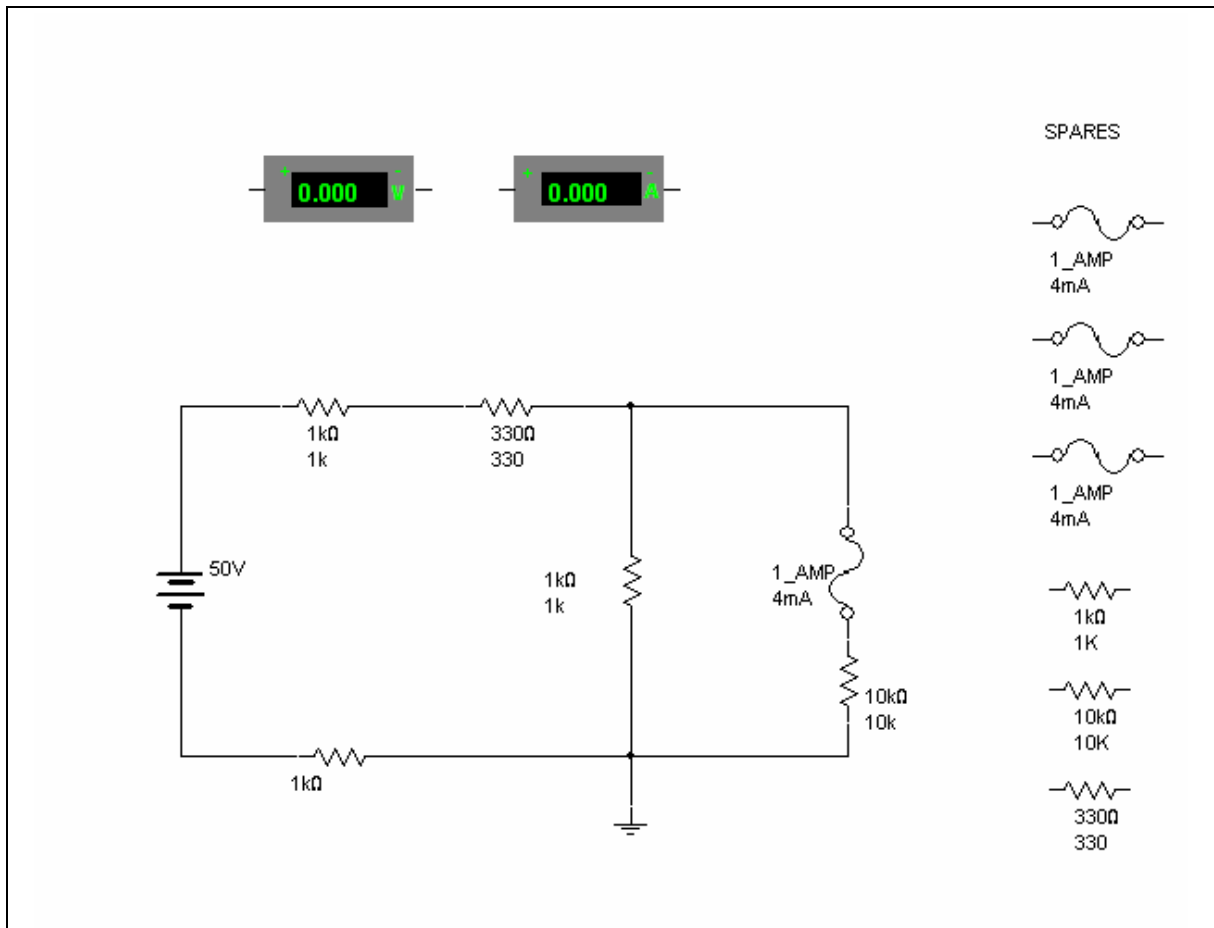

Questions

1. Solve the circuit. (Use the power switch.)
2. Describe the fault.

3. Describe the possibilities for faults that might produce the failure observed.

4. Replace the suspected component, solve and check for proper operation.
Hint: You have only three spare fuses. Result?

5. Continue to troubleshoot the circuit. Briefly describe the steps and results.

6. What is the solution?

Troubleshooting Activity 5-3: DC Circuits 3

Name: _____ ID Number: _____ Class: _____

Starting Point

Open **SeriesParallel3.ms10**.

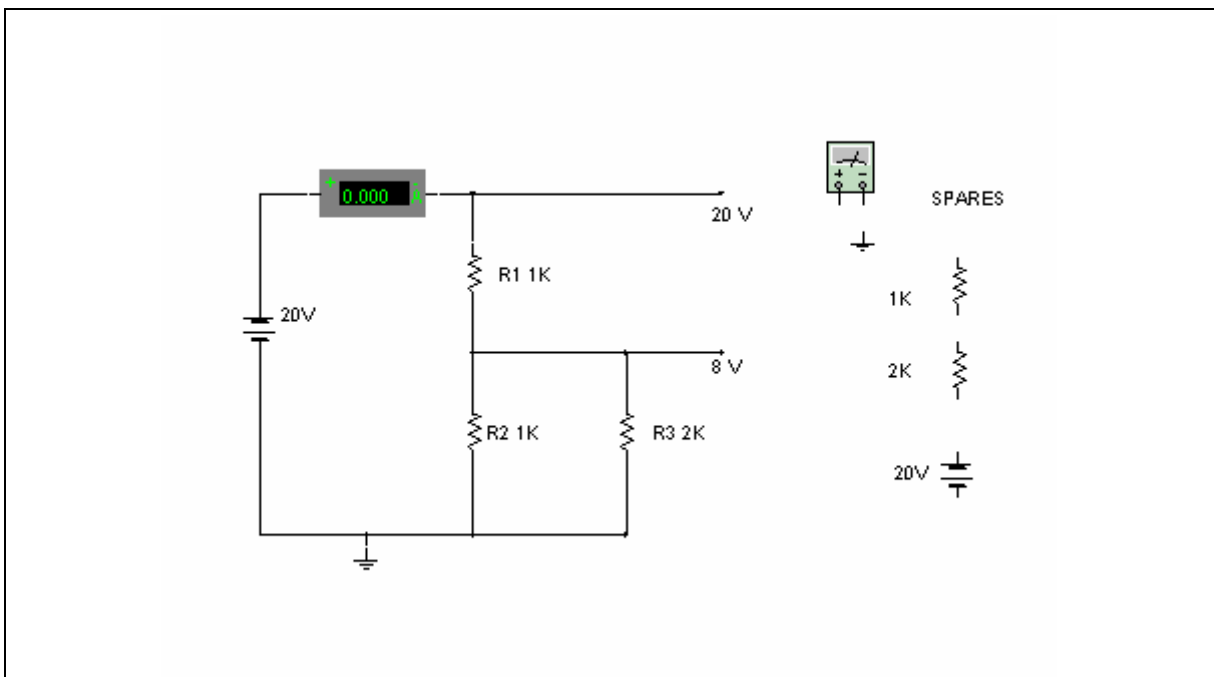

Notes

- This circuit displays correct voltages and current as in a service manual
- A bin of spare parts is provided so that you can replace the faulty component and check operation against the correct “service manual” values
- Faults can be open circuits, short circuits or wrong values.

Troubleshooting Activity 5-4: NPN, Voltage Divider Bias

Name: _____ ID Number: _____ Class: _____

Starting Point

Open `TroubleShooting2.ms10`.

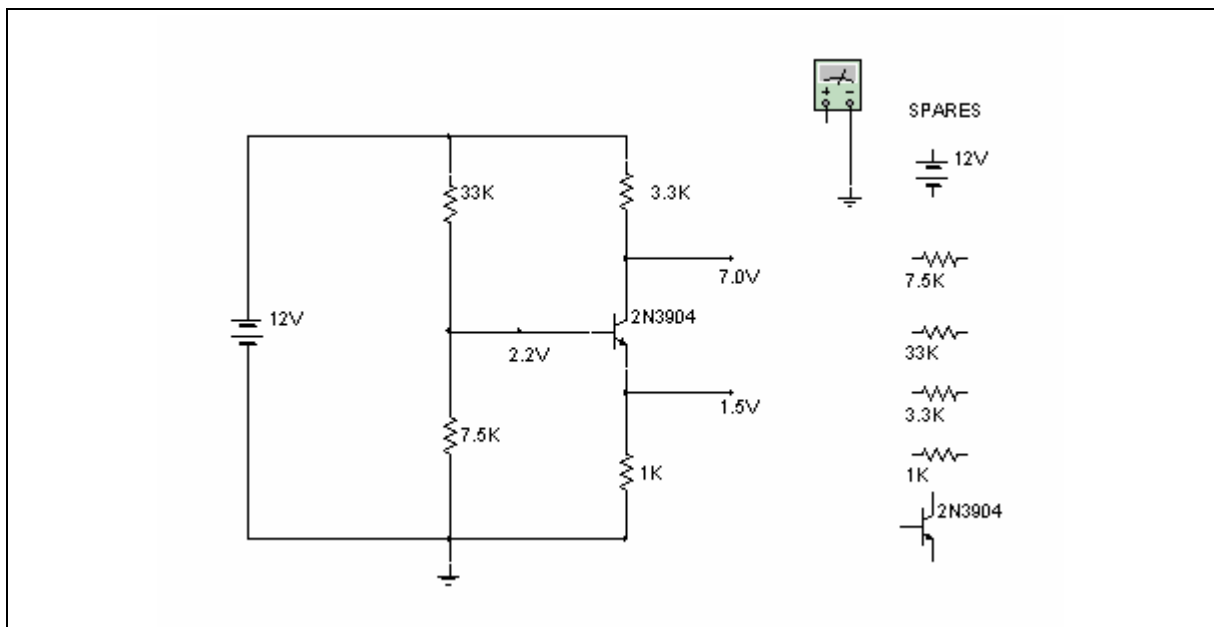

Notes

- Good troubleshooting procedures require thought after every measurement
- Remember, all measurements provided for below may *not* be necessary.

Questions

1. Describe the procedure used to find the fault in this circuit. DC measurements:

$V_{CC} =$

$V_C =$

$V_B =$

$V_E =$

$V_{CE} =$

$V_{BE} =$

2. Which measurement(s) appear to indicate the faulty component? Explain.

3. What is the next step?

Result:

4. The faulty component is therefore:
5. Replace the faulty component and check for proper circuit operation. Are repair results satisfactory?

6. How many measurements were necessary?

Questions

1. Describe the procedure used to find the fault:

a) AC measurements:

$V_{out} =$

$V_c =$

$V_b =$

$V_e =$

b) DC measurements:

$V_c =$

$V_B =$

$V_{E1} =$

$V_{E2} =$

$V_{BE} =$

$V_{CE} =$

2. The probable fault is (if obvious):

3. The next measurement will be:

Result:

4. Take more measurements (if necessary).

5. The faulty component is:

6. Replace the faulty component and test for proper operation. Are repair results satisfactory?

Troubleshooting Activity 5-6: Common Base Configuration

Name: _____ ID Number: _____ Class: _____

Starting Point

Open `CommonBaseTS.ms10`.

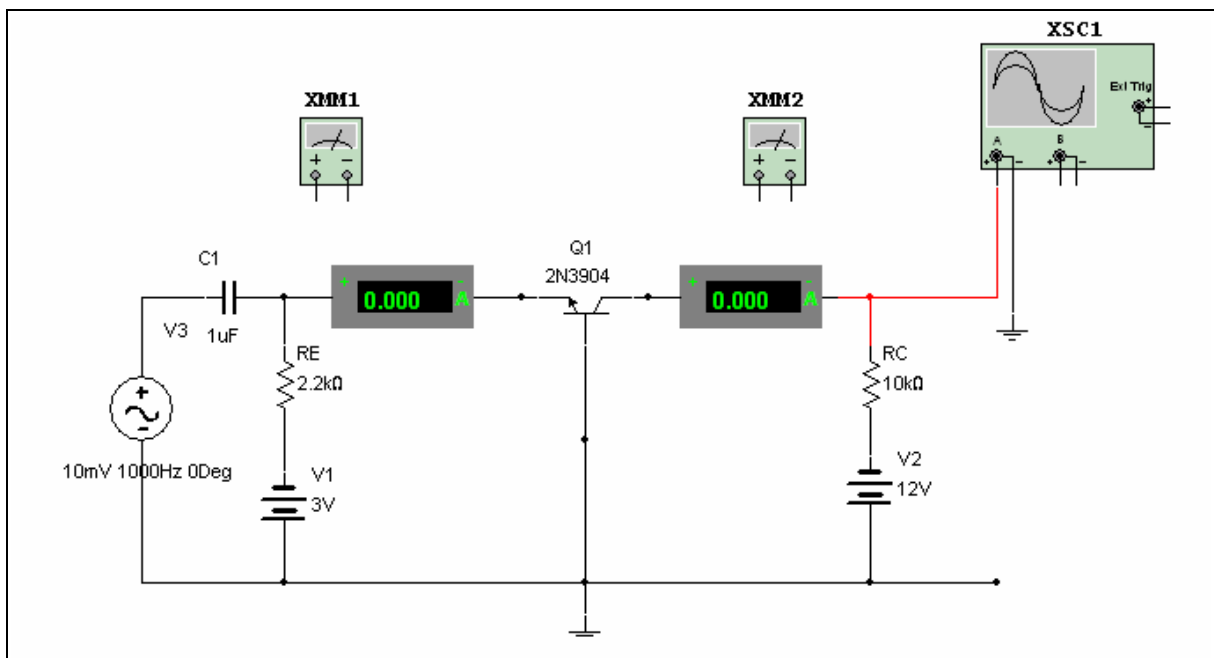

Notes

- The transistor should be operating in the linear region for correct operation.

4. Calculate VC.

5. Run the simulation and compare steps 1 through 4 using the multimeters.

IC =

IE =

VRC =

VC =

6. How do these values compare with your theoretical analysis? Is there a problem with this circuit? If so, what is it?

7. Measure the voltage between the base and emitter.

VBE =

8. Measure the voltage between the base and the collector.

VBC =

9. What region is the transistor operating in?

10. Why?

11. How would you alter this circuit in order to have the transistor operate in the linear region?

Troubleshooting Activity 5-7: Troubleshooting a Two-Stage Amplifier

Name: _____ ID Number: _____ Class: _____

Starting Point

Open file **TroubleShooting4.ms10**.

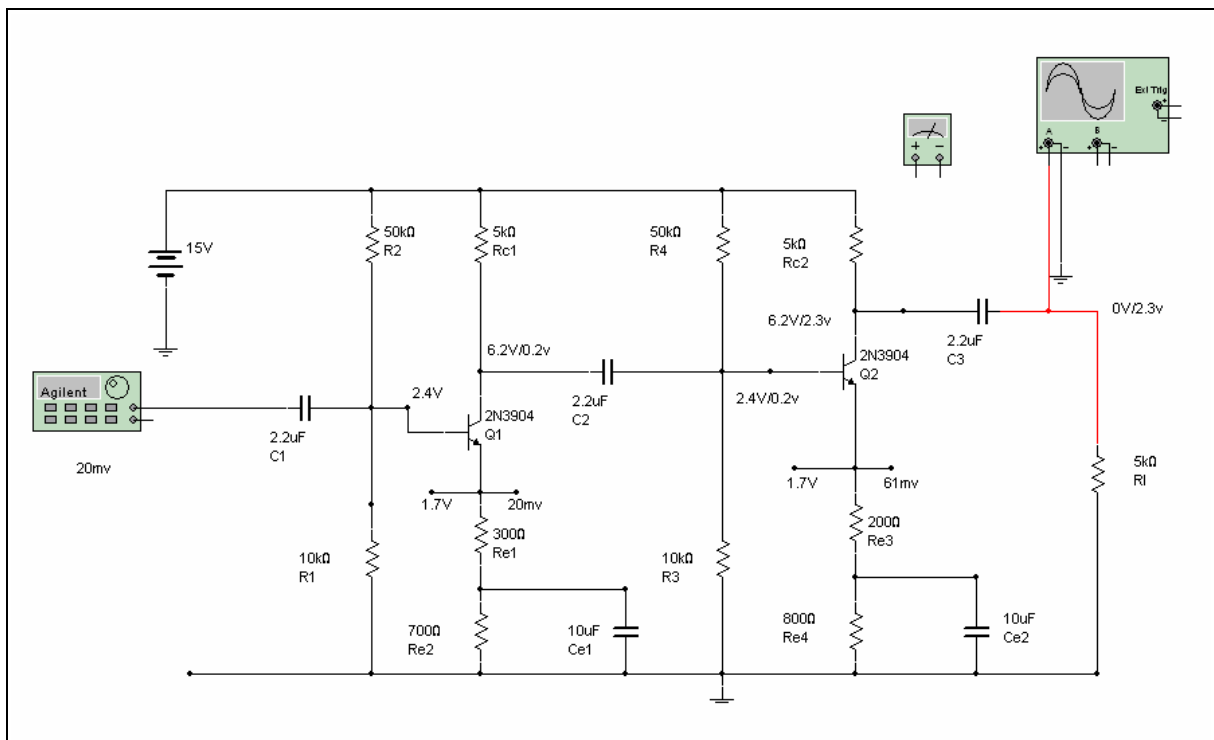

Notes

- Overall voltage gain (approx.) = 115
- Low 3 dB frequency = 100 Hz
- For V_{in} of 20 mV (p-p) at 1000 Hz, v_{out} is 2.3 v (p-p)
- DC voltage is shown with “V” and AC voltage with “v” (p-p).

Suggestions

- Faults may be due to changes in value of capacitors, changes in bias conditions due to faulty resistor values or drastic changes in current gain in the transistor
- Remember that it is often advantageous to remove the AC input and check the DC bias conditions
- Remember good troubleshooting practice and try to diagnose the fault with as few measurements as possible.

Questions

1. Describe the procedure, measurements, and conclusions as you isolate the faulty component in the circuit.
 - a)
 - b)
 - c)
 - d)
 - e)

Final Report

Troubleshooting Activity 5-8 Black Box Puzzles 1 and 2

Name: _____ ID Number: _____ Class: _____

Starting Point

Open file **Puzzle1.ms10** or **Puzzle2.ms10**.

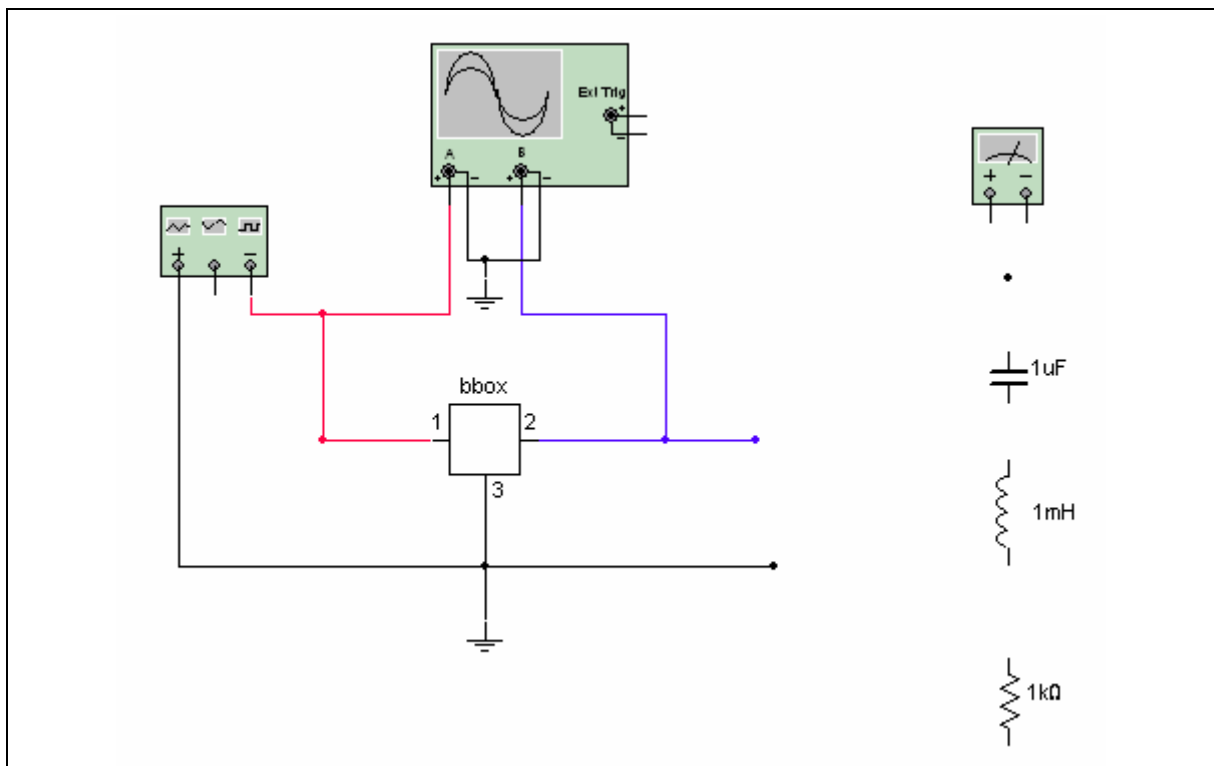

Questions

1. Set the signal generator to some frequency and amplitude. (Try starting at 1 kHz and 10 V peak.)
2. Observe the input and output voltages on channel A and B on the Oscilloscope.
3. Connect a resistor (load resistor) to the output (suggested start value of 1 k).

4. Adjust the generator frequency, the load resistor value, or both, so the output amplitude is significantly different than the input.
5. Phase shift provides a clue to the character of the unknown component:
No phase shift means it is resistive.
Leading phase shift means it is capacitive.
Lagging phase shift means it is inductive.

Measurements:

Load resistor value _____

Frequency _____

Input amplitude _____

Output amplitude _____

Phase shift? _____

Need to change resistor value? _____

New value _____

6. If changed:
Input amplitude _____
Output amplitude _____
Phase shift? _____
Leading or lagging? _____

7. Unknown is (circle one):
resistive
capacitive
inductive

8. Show the calculations that you used to determine the value of the unknown component:

Section 6: Operational Amplifiers

Section Contents

This section contains the following:

- “Introducing Op-Amps” on page 6-2.

Worksheets in this Section

The worksheets in this section begin on page 1 of Worksheet 6-1: Op-Amp Investigation 1: Inverting AC Amplifier:

- “Worksheet 6-1: Op-Amp Investigation 1: Inverting AC Amplifier”
- “Worksheet 6-2: Op-Amp Investigation 2: Non-inverting AC Amplifier”
- “Worksheet 6-3: Active Band-Pass Filter”
- “Worksheet 6-4: Series-Pass Voltage Regulator”
- “Worksheet 6-5: Integrator”
- “Worksheet 6-6: Phase Shift Oscillator”
- “Worksheet 6-7: Pulse-Width Modulator”.

Circuits for this Section

The following is a list of the file names of circuits used in this section and a brief description of each.

File (.ms10)	Description
ActiveBandPassFilter	An active band pass filter.
Integrator	A circuit which provides integration.
InvertingAmplifier	AC operation of an inverting op-amp circuit.
NonInvertingAmplifier	AC operation of a non-inverting op-amp circuit.
PhaseShiftOscillator	A Phase Shift Oscillator.
PWM	A pulse width modulator circuit.
SeriesPassVoltageRegulator	A linear series pass regulator circuit with an op-amp error amplifier.

Introducing Op-Amps

The exercises in this section are meant to generate student interest in the topic area of Operational Amplifiers.

Presentation can be in several ways, depending on available facilities:

- For distance learning
- As a classroom demonstration with PowerPoint
- In a software lab.

Regardless of their presentation, the exercises are intended to promote discussion, in class or out, of device and circuit behavior in the hopes of lending more meaning to basic theory.

The files **Integrator.ms10**, **ActiveBandPassFilter.ms10**, **SeriesPassVoltageRegulator** (a series pass voltage regulator with op-amp error amp) and **PWM.ms10** (a pulse width modulator) require more in-depth knowledge of op-amp characteristics and are intended to be used later in a course on op-amp applications.

Goal

To introduce a method of how Multisim may be used to familiarize students with basic operating concepts of operational amplifiers.

Prerequisites

You will require the following circuit files:

- **InvertingAmplifier.ms10**
- **NonInvertingAmplifier.ms10**.

Students should be familiar with:

- Measurements in Multisim, including use of the Oscilloscope and meters
- The basic theory of op-amps.

References

Topic	Page
Bode Plotter	Multisim User Guide: Ch. 8 "Instruments"

Worksheet 6-1: Op-Amp Investigation 1: Inverting AC Amplifier

Name: _____ ID Number: _____ Class: _____

Starting Point

Open file **InvertingAmplifier.ms10**.

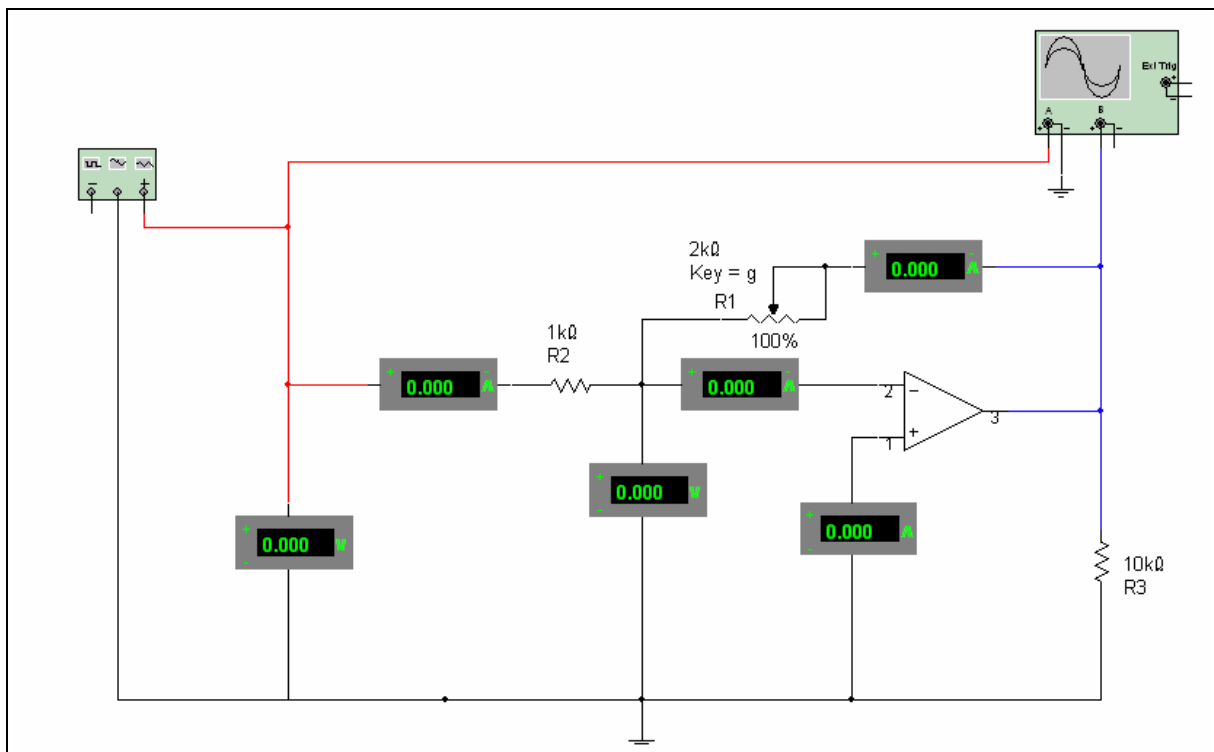

Questions

1. Set input to 0 V (input pot P to 0%) and observe all AC voltages and currents. Compare with text or lecture theory.

2. Select a new value of input voltage using the G or SHIFT-G key to vary the input and repeat the observations. You can also hover your cursor over the potentiometer and drag the slider bar that appears.

3. Check that the *difference* between the inverting and non-inverting terminals times the *open loop* gain is equal to the output.
 - a) Inverting terminal =
 - b) Non-inverting terminal =
 - c) Difference =
 - d) Open loop gain =
 - e) Calculated result =
 - f) Measured output =

4. Use the scope or Bode Plotter to find the upper and lower corner (or break) frequencies.
 - a) Upper corner =
 - b) Lower corner =

5. Increase the input amplitude until output clipping occurs. Compare the maximum peak-to-peak output with the supply voltages.
 - a) Maximum p-p output =
 - b) Supply voltages =

NI ELVIS Exercise

Starting Point

Open file `InvertingAmplifier.ms10` in Multisim. Create the circuit on your NI ELVIS breadboard, as shown in the figure below.

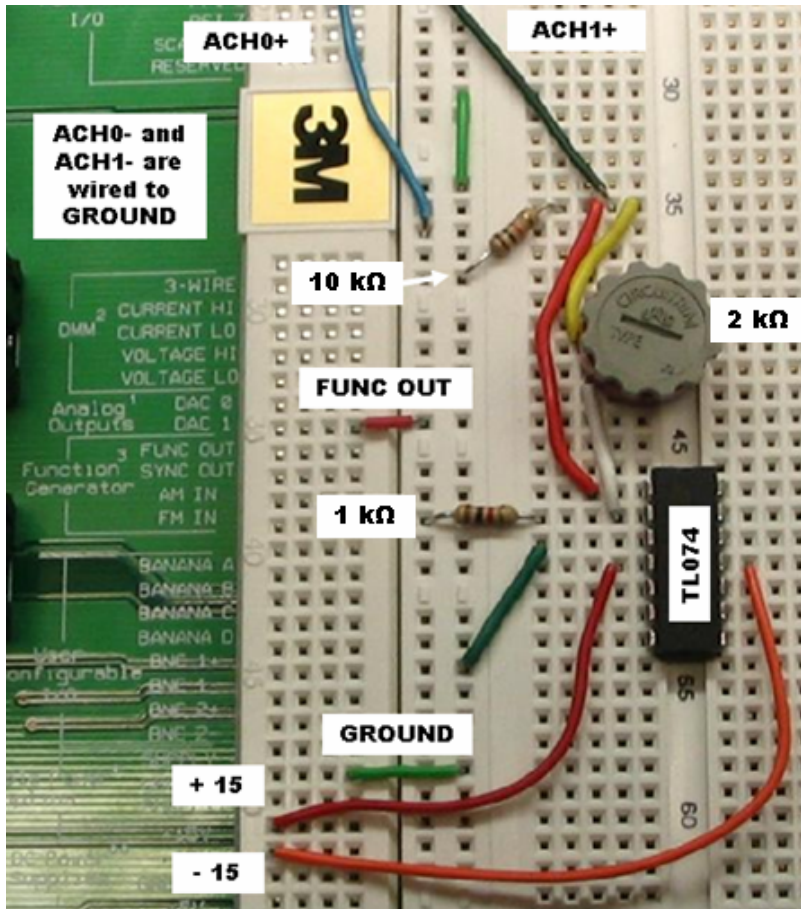

Notes

- Use the Function Generator on the NI ELVIS hardware to control the frequency and amplitude of the sine wave input to the circuit.

Questions

1. In Multisim:
 - a) Set variable resistor, R1, 0 Ω and observe all AC voltages and currents. Compare with text or lecture theory.

 - b) Select a new value of R1 using the G or SHIFT-G key to vary the input and repeat the observations. You can also hover the cursor over the potentiometer and drag the slider bar that appears.

2. On the circuit built on NI ELVIS, increase and decrease the resistance of R1. What observations can you make?

3. Verify that the *difference* between the inverting and non-inverting terminals times the *open loop* gain is equal to the output.

Simulated

Measured

Inverting terminal

Non-inverting terminal

Difference

Open loop gain

Calculated result

Measured output

4. Use the scope or Bode Plotter to find the upper and lower corner (-3 dB) frequencies.

Frequencies

Simulated

Measured

Upper corner

Lower corner

Worksheet 6-2: Op-Amp Investigation 2: Non-inverting AC Amplifier

Name: _____ ID Number: _____ Class: _____

Starting Point

Open file **NonInvertingAmplifier.ms10**.

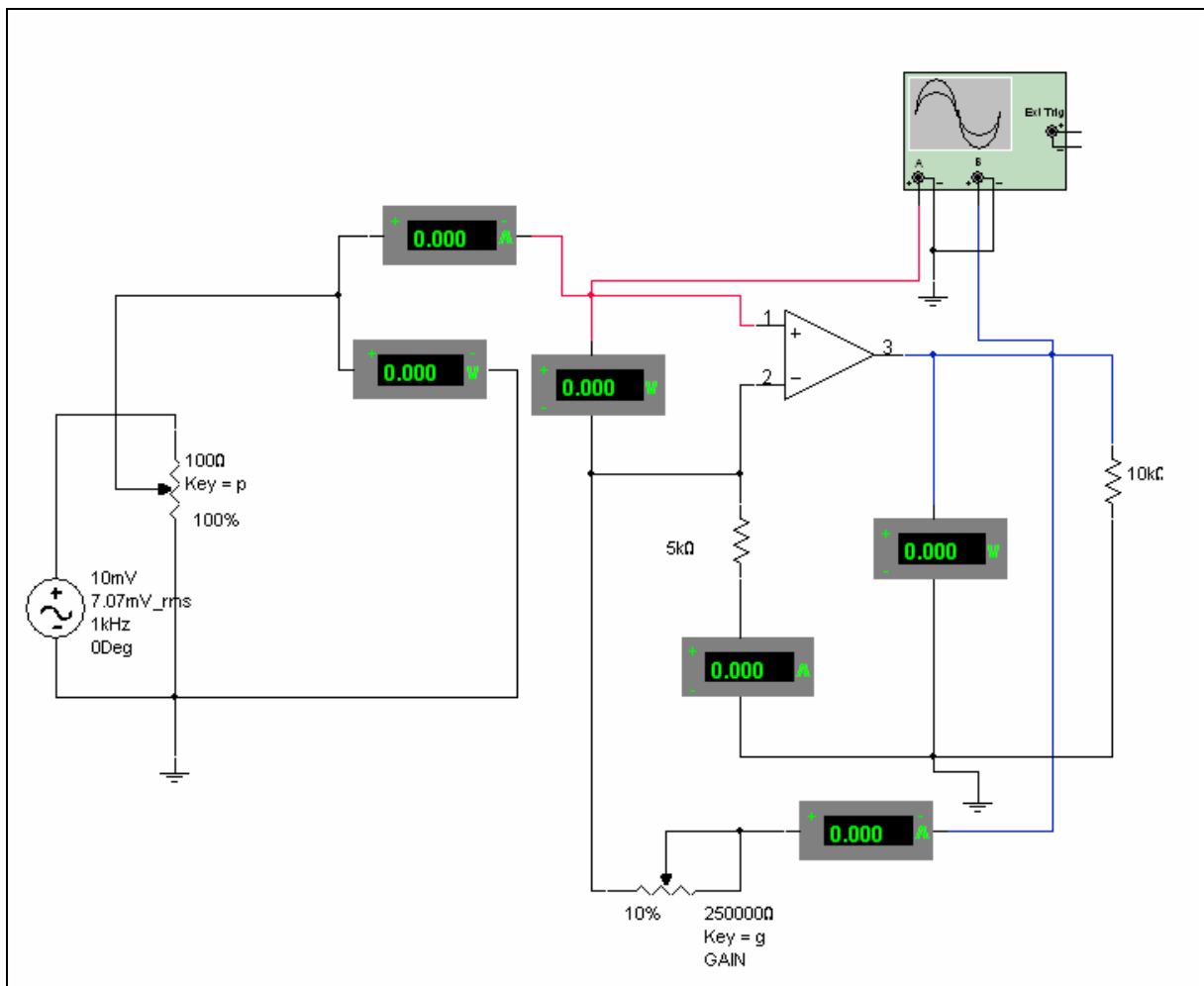

Questions

1. Set input to 0 V (input pot G to 0%) and observe all AC voltages and currents. Compare with text or lecture theory.

Comparison:

2. Select a new value of input voltage using the G or SHIFT-G key to vary the input and repeat the observations. You can also hover your cursor over the potentiometer and drag the slider bar that appears.

Comparison:

3. Check that the *difference* between the inverting and non-inverting inputs times the *open loop* gain is equal to the output.

Inverting terminal =

Non-inverting terminal =

Difference =

Open loop gain =

Calculated result =

Measured output =

4. Use the scope or Bode Plotter to find the upper and lower corner (or break) frequencies.

Upper corner =

Lower corner =

5. Increase the input amplitude until output clipping occurs. Compare the maximum peak-to-peak output with the supply voltages.

Maximum p-p output =

Supply voltages =

Worksheet 6-3: Active Band-Pass Filter

Name: _____ ID Number: _____ Class: _____

Starting Point

Open file **ActiveBandPassFilter.ms10**.

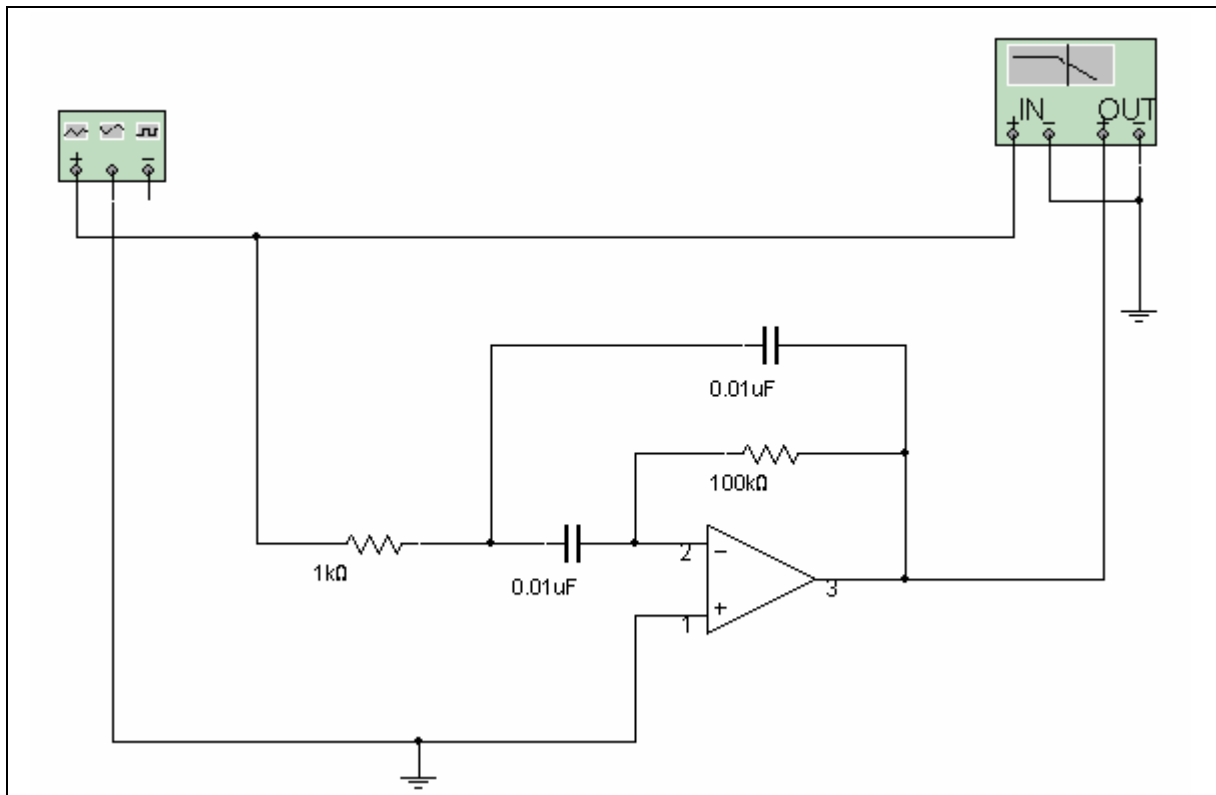

Design information was obtained from *Linear Integrated Circuits* by Winzer.

NI ELVIS Exercise

Starting Point

On your NI ELVIS breadboard, create the band pass filter circuit that you simulated and studied in the **ActiveBandPassFilter.ms10** file. The image below is an example implementation. Open **ActiveBandPassFilter.ms10** and run the simulation so you have a useful reference and a better idea of how the circuit functions.

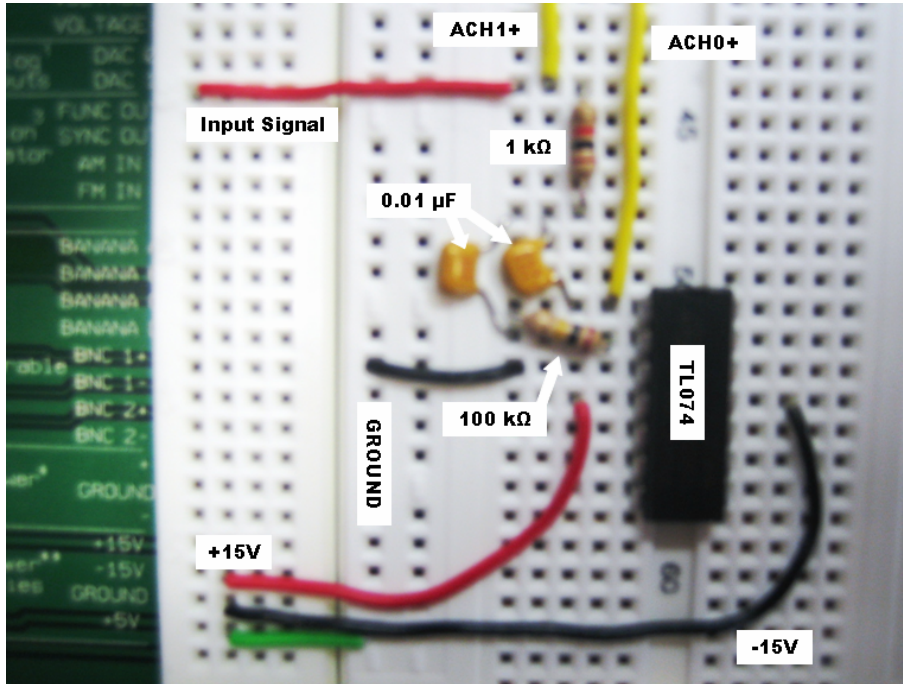

In the circuit shown above, ACH0 is used to measure the output voltage while ACH1 is used to measure the input voltage. The negative pins of both of these channels are wired to ground. The NI ELVIS Bode Analyzer takes these two analog signals and creates the bode response of the circuit by passing generating the necessary signals at the input (FUNC OUT).

Questions

1. Analyze the circuit above using the op-amp theory you have learned in class.
2. Compare your physical results using NI ELVIS with the simulated circuit outputs.

Worksheet 6-4: Series-Pass Voltage Regulator

Name: _____ ID Number: _____ Class: _____

Starting Point

Open file **SeriesPassVoltageRegulator.ms10**.

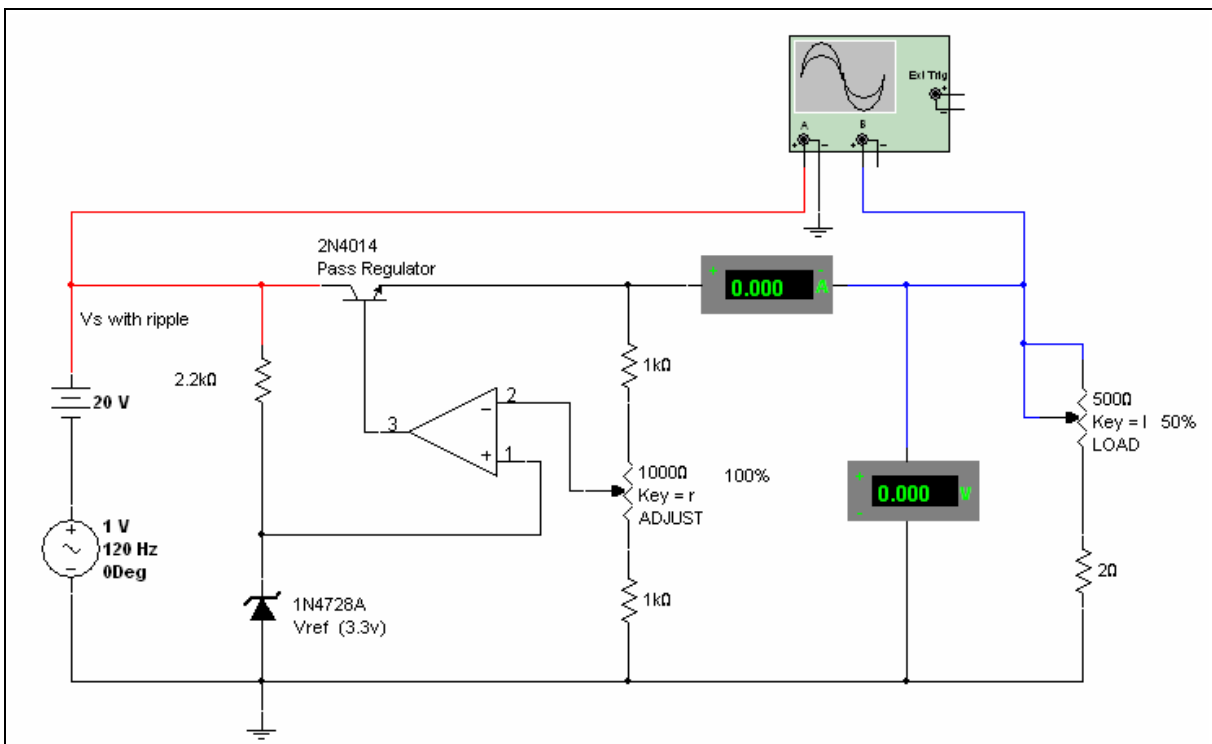

Notes

- The raw supply is represented by a 20 V battery with an AC source in series to simulate a 120 Hz full wave ripple of approximately 3 V(p-p)
- Load current is varied with the L or SHIFT-L key
- Regulated output voltage is varied with the R or SHIFT-R key. You can also hover your cursor over a potentiometer and drag the slider bar that appears.

Questions

1. With the voltage adjust pot at mid-position (50%), calculate the expected output voltage.
2. With the voltage adjust and load pots at mid position (50%), measure the output voltage, current and ripple.
3. With output voltage at about 6 V, plot a curve of output voltage and ripple against load current for load resistance steps of 10%.
4. From measured results, calculate the voltage regulation of the circuit.
5. From measured results, calculate the ripple voltage rejection of the circuit.

Worksheet 6-5: Integrator

Name: _____ ID Number: _____ Class: _____

Starting Point

Open file **Integrator.ms10**.

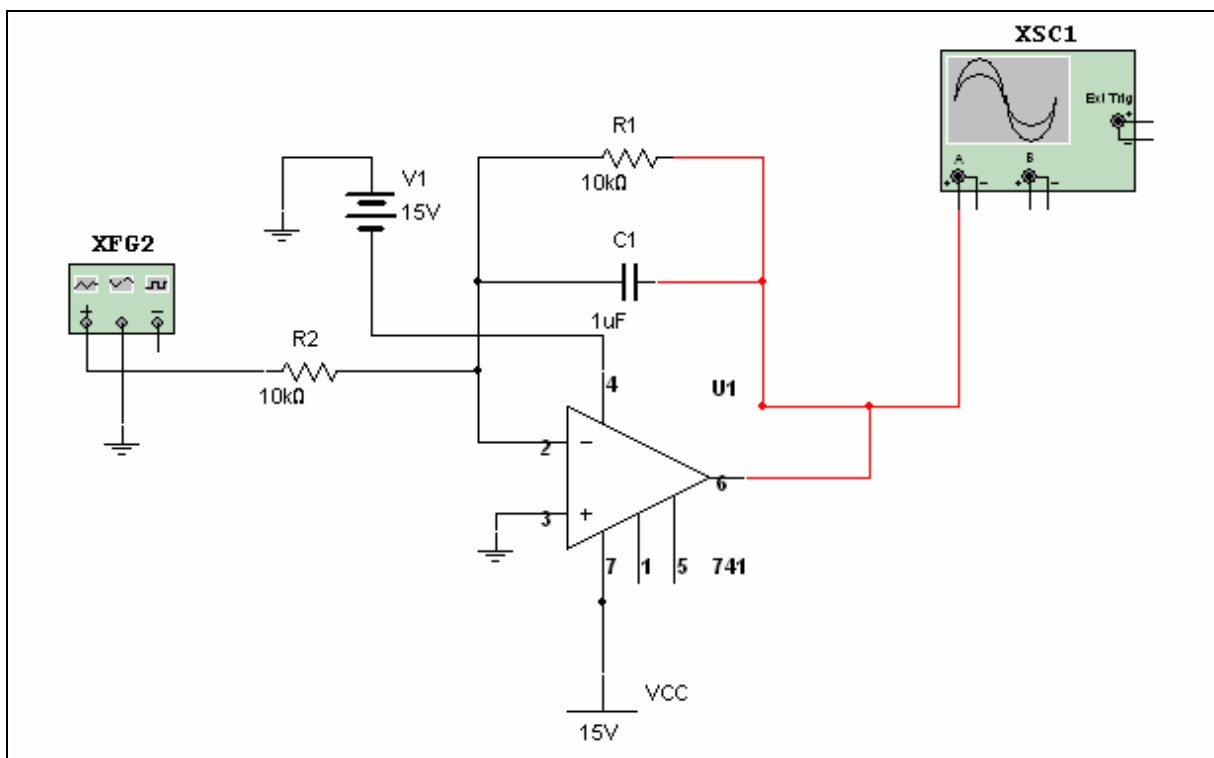

Question

- Given that the peak-to-peak voltage = 20 V, the frequency = 1 kHz and the output is a triangle wave, calculate V_{out} .

- Run the simulation and compare your results.

NI ELVIS Exercise

Starting Point

On your NI ELVIS breadboard, create the integrator circuit that you simulated and studied in the **Integrator.ms10** file. The image below is an example implementation. Open **Integrator.ms10** and run the simulation so you have a useful reference and a better idea of how the circuit functions.

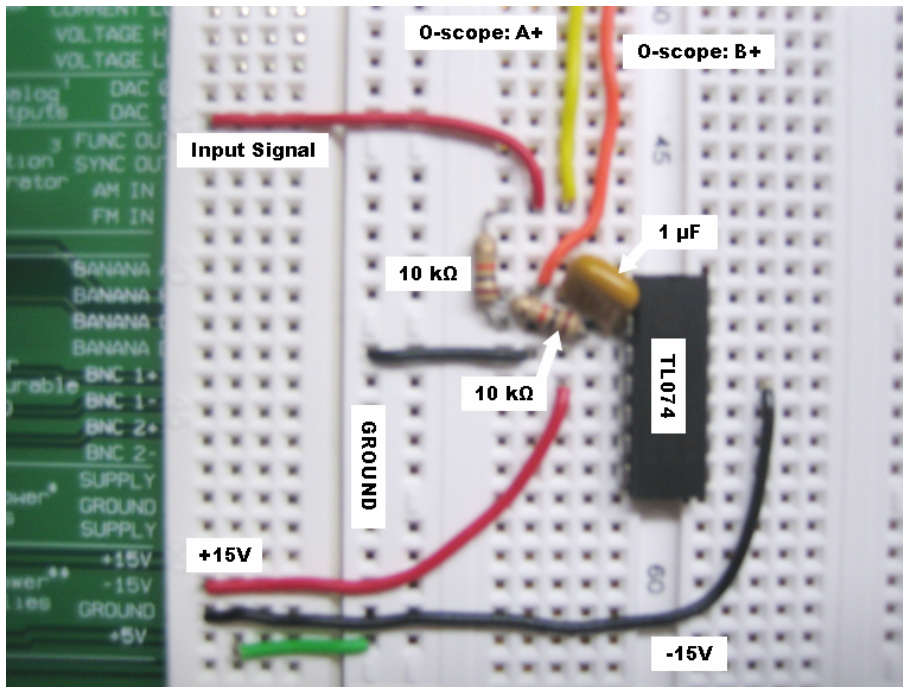

The function generator (FUNC OUT) is used in the circuit above to generate the 1 kHz triangle wave input signal with amplitude of 2 V. Channel A of the oscilloscope is the circuit input and channel B is the output. The A- and B- pins are both wired to ground.

Questions

- Analyze the circuit above using the op-amp theory you have learned in class.
- Compare your physical results using NI ELVIS with the simulated circuit outputs.

Worksheet 6-6: Phase Shift Oscillator

Name: _____ ID Number: _____ Class: _____

Starting Point

Open file **PhaseShiftOscillator.ms10**.

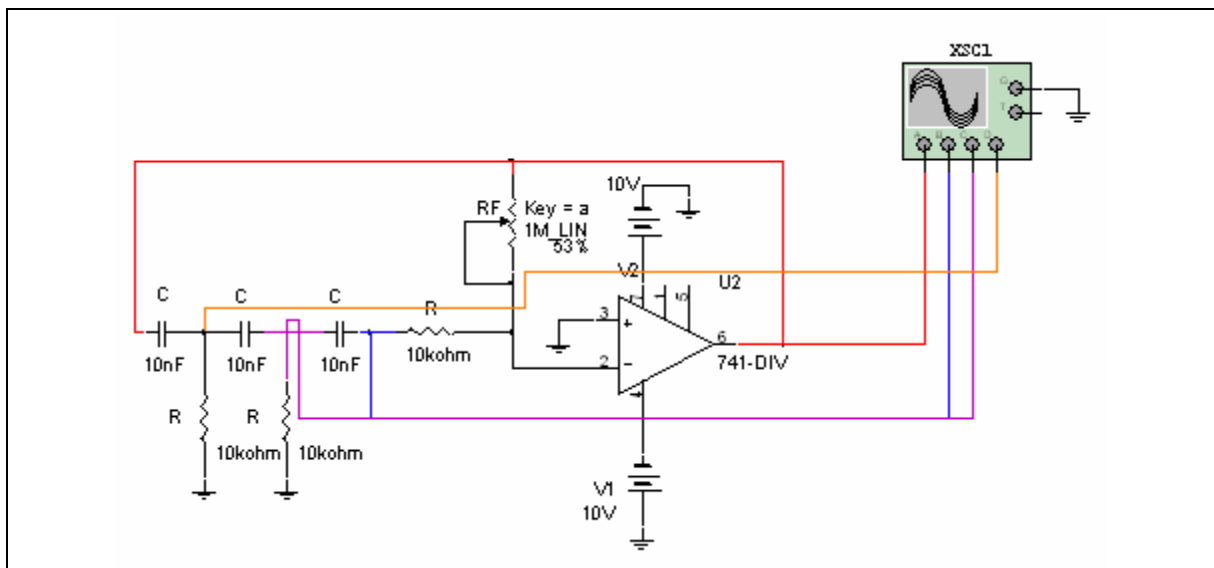

Question

1. Run the simulation. Be patient. It may take several seconds for the oscillations to begin.
2. Measure the frequency at the output.

3. Vary the potentiometer until oscillations begin. Calculate the value of R_f/R at the point where oscillations begin.

$R_f/R =$

Worksheet 6-7: Pulse-Width Modulator

Name: _____ ID Number: _____ Class: _____

Starting Point

Open file PWM.ms10.

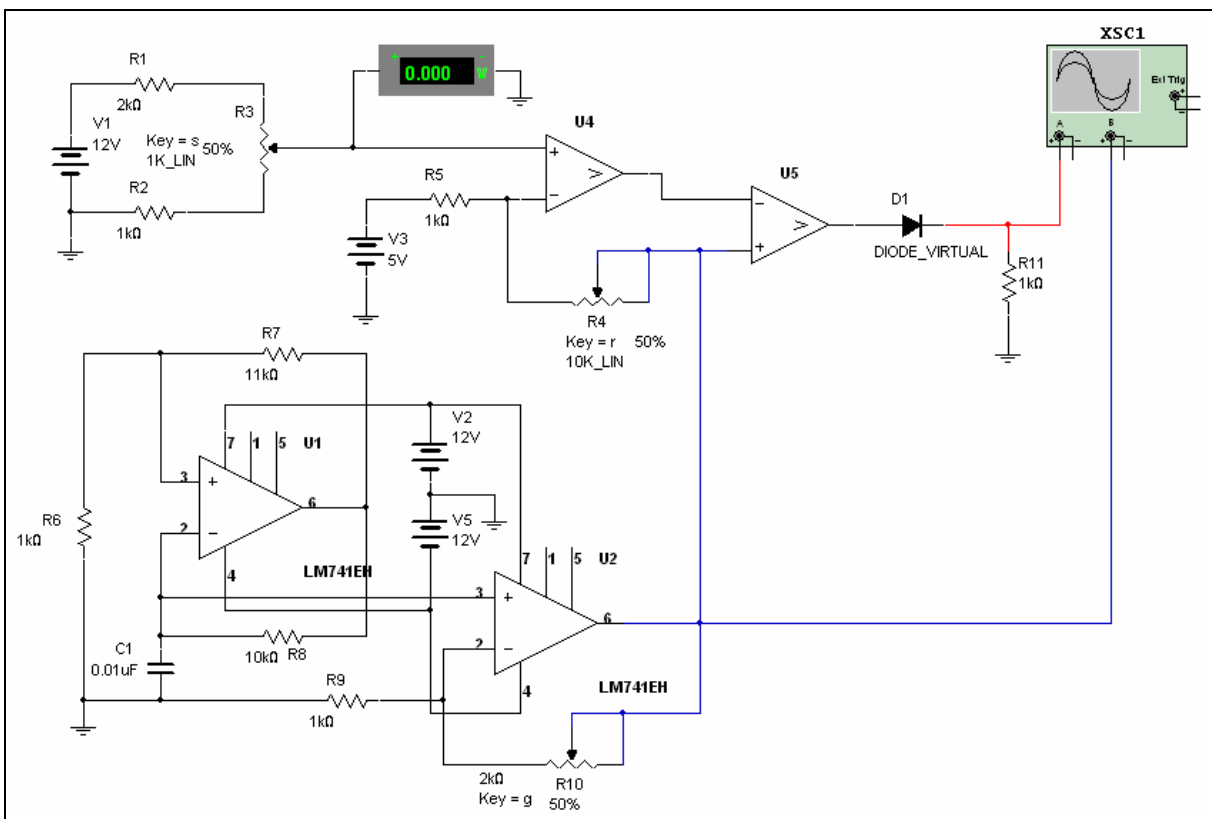

Notes

- Possible application as a driver for a switch-mode regulated power supply
- Potentiometer S represents a sampled DC voltage (the “error” voltage) and pulse width varies with error voltage
- Loop gain is adjusted with potentiometer G.

Questions

1. Start with all pots at 50%. Observe the output pulse width and duty cycle. Record values.

Pot S = Pulse width = Duty cycle =

Pot G = Pulse width = Duty cycle =

Pot R = Pulse width = Duty cycle =

2. Change the sampled voltage with S or SHIFT-S and observe the effect on pulse width and duty cycle. You can also hover your cursor over the potentiometer and drag the slider bar that appears.

Pot S = Pulse width = Duty cycle =

Pot G = Pulse width = Duty cycle =

Pot R = Pulse width = Duty cycle =

3. Change loop gain by 20% or so and repeat. Comment on the effect on circuit operation.

Pot S = Pulse width = Duty cycle =

Pot G = Pulse width = Duty cycle =

Pot R = Pulse width = Duty cycle =

Section 7: Thyristors and Switches

Section Contents

This section contains the following:

- “Introducing Thyristors and Switches” on page 7-2.

Worksheets in this Section

The worksheets in this section begin on page 1 of Worksheet 7-1: SCRs: Simple Resistive Control of an SCR.

- “Worksheet 7-1: SCRs: Simple Resistive Control of an SCR”
- “Worksheet 7-2: Investigating DIAC Characteristics”
- “Worksheet 7-3: SCR and DIAC”
- “Worksheet 7-4: Using Phase Shift and a DIAC to Control an SCR”
- “Worksheet 7-5: Application for a Voltage-Controlled Switch (VCS)”.

Circuits for this Section

The following is a list of the file names of circuits used in this section and a brief description of each.

File (.ms10)	Description
DiacCharacteristics	DIAC Characteristics.
PhaseShiftControl	Phase shift control of SCR conduction.
SCR1	SCR Familiarization (resistive control).
SCRDiac	SCR with DIAC.
VoltageControlledSwitch	A voltage controlled switch and RC circuit to make up a relaxation oscillator.

Introducing Thyristors and Switches

The exercises in this section are meant to generate student interest in the topic area of thyristors and switches. They are intended to demonstrate to the student the characteristics of each device.

Several options exist for presentation, depending on program requirements and facilities:

- As a segment of a distance learning program
- As a classroom demonstration with over head projection
- With PowerPoint
- As a software lab.

It is hoped that these exercises will promote further interest in topic area theory. Basic characteristics of switching devices such as the SCR, DIAC and the voltage controlled switch (VCS) will be introduced. A phase shift control section is also included. There are a total of five **.ms10** files associated with this section.

Goal

To introduce the basic characteristics of switching devices such as the SCR and DIAC, simple phase control of AC power with an SCR and DIAC as well as the VCS which is included in the Multisim component list.

Prerequisites

Students are expected to have:

- Familiarity with Multisim and measurements, both AC and DC, using the scope and meters. (Or see comments below)
- An introduction to the (very) basic theory of the SCR and DIAC
- Familiarity with RC time constants and phase shift in RC circuits.

Worksheet 7-1: SCRs: Simple Resistive Control of an SCR

Name: _____ ID Number: _____ Class: _____

Starting Point

Open file **SCR1.ms10**.

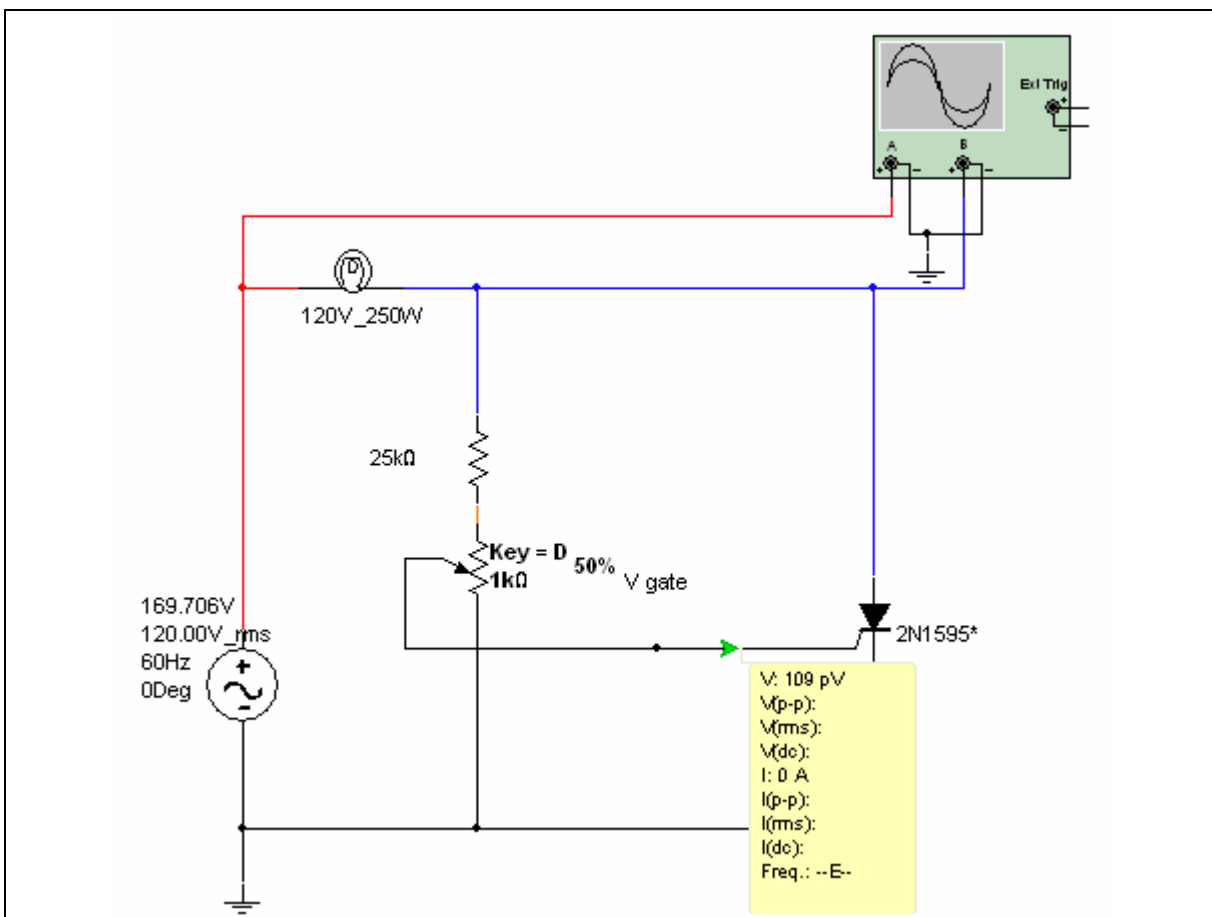

Notes

- Potentiometer D is the "dimmer" control.
- The lamp flashes on when the SCR conducts.

- b) Confirm with calculations that these points agree with theory.
5. Record the values of V_{gt} , I_{gt} and I_h for the ideal SCR.
6. Change the power rating of the lamp to 10 watts, set the dimmer to 25% and solve the circuit.
7. Explain why the SCR comes out of conduction before the supply voltage reaches zero as it did previously.
8. Change the SCR from the ideal model to a 2N1599. Solve the circuit and explain why this SCR conducts to the end of the positive half cycle. (Check the model values).

9. Choose a different SCR and repeat steps 1 - 3. Report briefly on the results of this investigation.

Worksheet 7-2: Investigating DIAC Characteristics

Name: _____ ID Number: _____ Class: _____

Starting Point

Open file **DiacCharacteristics.ms10**.

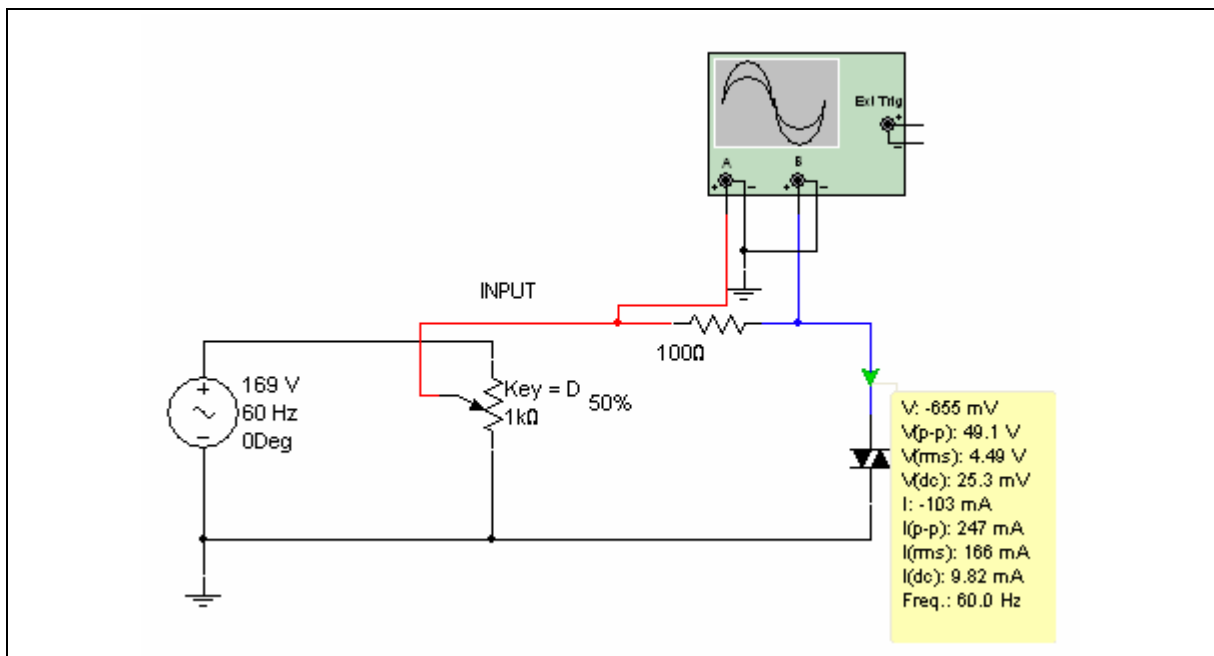

Notes

- Potentiometer D varies the voltage applied to the DIAC
- The 100 ohm resistor limits DIAC current to a safe level.

Questions

1. Assuming the DIAC turns on (conducts) when the applied voltage reaches 10 V, and that the input control is set at 50% (500 ohms from wiper to ground), calculate the point in the AC supply waveform at which the DIAC will turn on. (How many degrees?)

2. Set the input control at 50% and solve the circuit. Confirm, by measuring, the calculated value from step 2.

3. Vary the input. Record the input voltage at which the DIAC stops conducting. Explain.

4. Record the values of V_s , V_{tm} and I_h for the ideal DIAC (obtained from the Edit Model window).

Worksheet 7-3: SCR and DIAC

Name: _____ ID Number: _____ Class: _____

Starting Point

Open file **SCRDiac.ms10**.

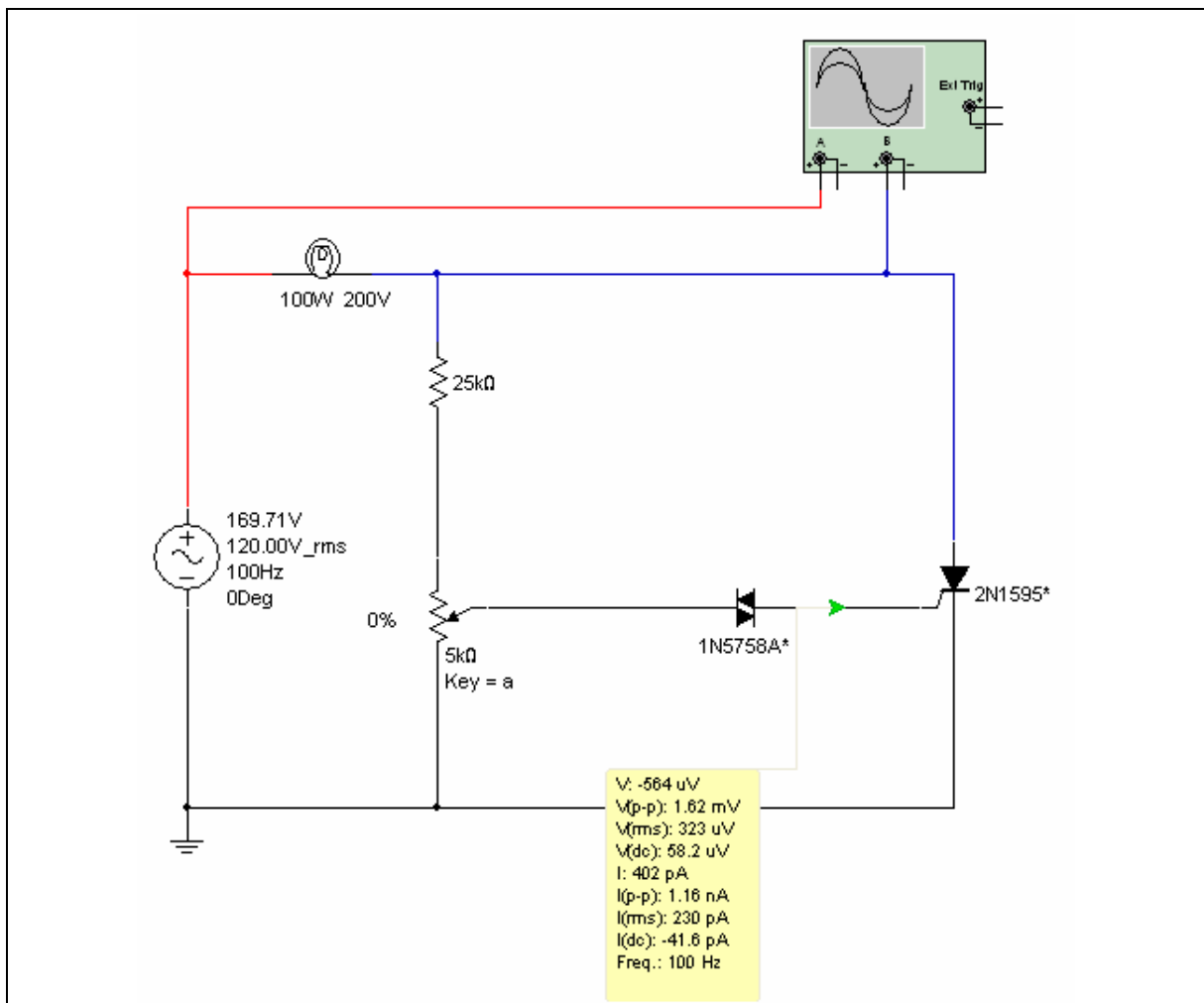

- b) Confirm with calculations that these points agree with theory.
5. Record the values of V_{gt} , I_{gt} and I_h for the ideal SCR (obtained from the Edit Model dialog).
6. Change the power rating of the lamp to 10 watts, set the dimmer to 50% and solve the circuit. Explain why the SCR comes out of conduction before the supply voltage reaches zero as it did previously.

Worksheet 7-4: Using Phase Shift and a DIAC to Control an SCR

Name: _____ ID Number: _____ Class: _____

Starting Point

Open file **PhaseShiftControl.ms10**.

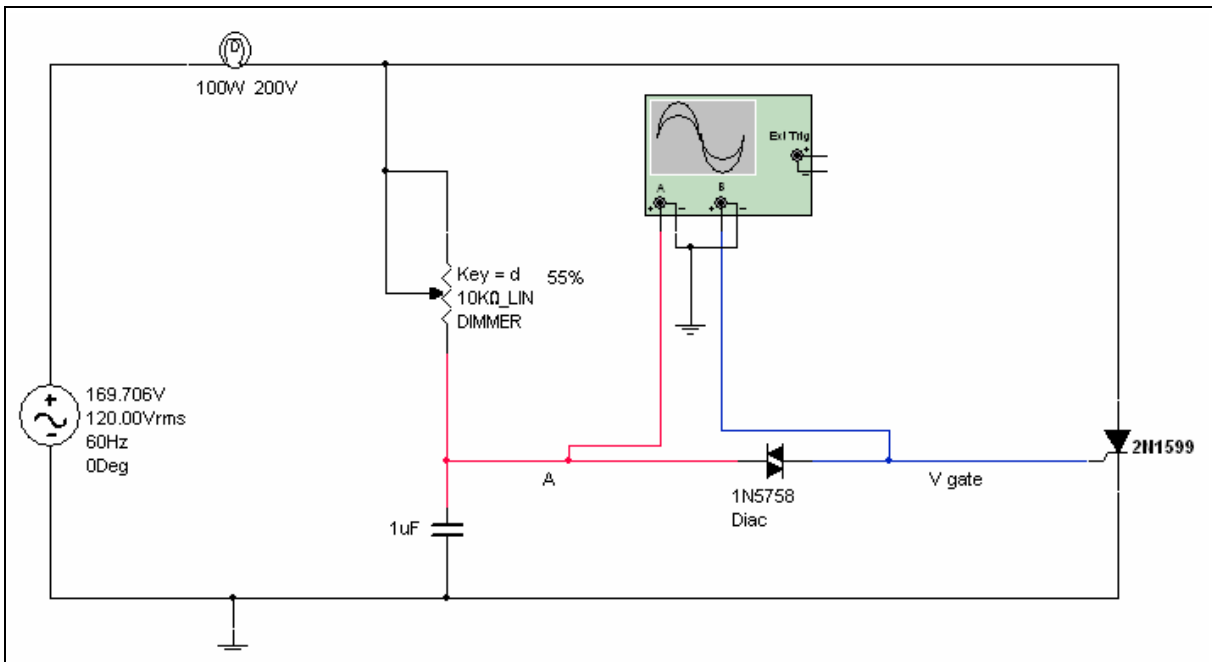

Notes

- This activity shows the students how phase shift and a DIAC allow wider conduction control of an SCR.
- Potentiometer D is the "dimmer" control.
- Note that the lamp flashes on when the SCR conducts.

- b) Confirm, with calculations that these points agree with theory.
5. Report briefly on the results of this investigation, including an explanation of the much greater control this circuit has on conduction angle than either of the simpler control circuits. (See files **SCR1.ms10** and **SCRDiac.ms10**).

Worksheet 7-5: Application for a Voltage-Controlled Switch (VCS)

Name: _____ ID Number: _____ Class: _____

Starting Point

Open file **VoltageControlledSwitch.ms10**.

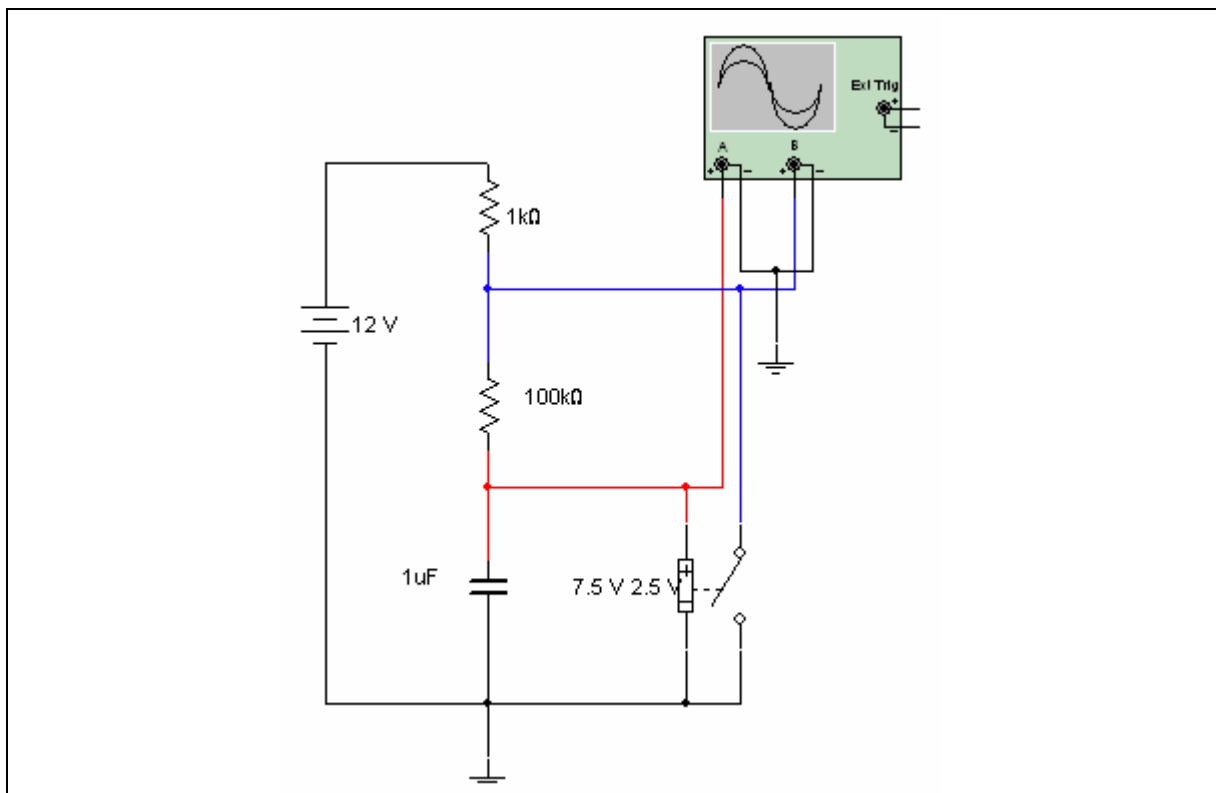

Notes

- This circuit may be used to demonstrate or investigate RC time constants.
- This circuit is a relaxation oscillator which simulates the operation of a 555 timer as an astable oscillator. The VCS is set to close when the voltage is 10 V (or $2/3 V_{cc}$ as the upper threshold in a 555 timer) and open when the voltage is at 5 V (or $1/3 V_{cc}$ as is the lower threshold in a 555).

Questions

1. Solve the circuit and measure times for charge and discharge of the capacitor.
2. Compare charge and discharge times with theoretical values using RC time constant theory.

3. For additional investigations, set the threshold voltages of the VCS by double-clicking the VCS.

Section 8: Digital Circuits

Section Contents

This section contains the following:

- “Introducing Digital Circuits” on page 8-2
- “555 Timer Astable Oscillator” on page 8-3
- Asynchronous Counter on page 8-4
- Demultiplexer on page 8-6
- Synchronous BCD Counter Using Discrete Elements on page 8-8

Worksheets in this Section

The worksheets in this section start on page 1 of Worksheet 8-1: 555 Timer Astable Oscillator

- “Worksheet 8-1: 555 Timer Astable Oscillator”
- “Worksheet 8-2: Digital Circuit Example 1”
- “Worksheet 8-3: Digital Circuit Example 2”
- “Worksheet 8-4: Digital Circuit Example 3”
- “Worksheet 8-5: Digital Circuit Example 4”.

Circuits for this Section

The following is a list of the file names of circuits used in this section and a brief description of each.

File (.ms10)	Description
Dig1, Dig1A - C	Combinational logic circuit and progressive introduction to digital test equipment.
555Astab	The 555 timer as an astable oscillator.
AsynchronCounter	An asynchronous counter using discrete JK flip-flops.
SynchronCounter	A synchronous counter using discrete JK flip-flops and gates.
Demultiplexer	A 3-to-8 demultiplexer.

Introducing Digital Circuits

This section contains a series of eight files that illustrate some of Multisim's features in the operation of digital circuitry. Some of the basic features of the digital test equipment available in Multisim are demonstrated.

The circuits **Dig1.ms10**, **Dig1A.ms10**, **Dig1B.ms10** and **Dig1C.ms10** are the same circuit investigated in different ways. Any digital example may be substituted. This circuit is a combinational logic circuit, similar to an example in the text *Digital Fundamentals* (Floyd, Ed. 5). The circuit consists of limit switches that monitor a particular function. When the inputs are low, the LED is off. When the inputs are high, the LED is on. Multisim also allows the option of substituting a buzzer for the LED.

Illustrations on the use of Multisim's 555 timer are also provided in circuit file **555Astab.ms10**. Examples of an asynchronous counter and a demultiplexer are found in files **AsynchronCounter.ms10** and **Demultiplexer.ms10**.

These files can be presented to familiarize both distance learning and conventional students with the variety of digital equipment available. They provide a simulated hands-on learning experience that should be augmented through use of a more traditional laboratory.

Goals

- To apply Multisim in evaluation of digital circuits
- To introduce various digital equipment available in Multisim
- To introduce and demonstrate the use of the 555 timer available in Multisim.

Prerequisites

Students should have a prior introduction to digital theory including:

- AND gates, OR gates, truth tables, flip-flops, synchronous and asynchronous counters, RC time constants and the 555 timer
- Have an understanding of the Multisim environment including the use of the multimeter, Oscilloscope and various components.

555 Timer Astable Oscillator

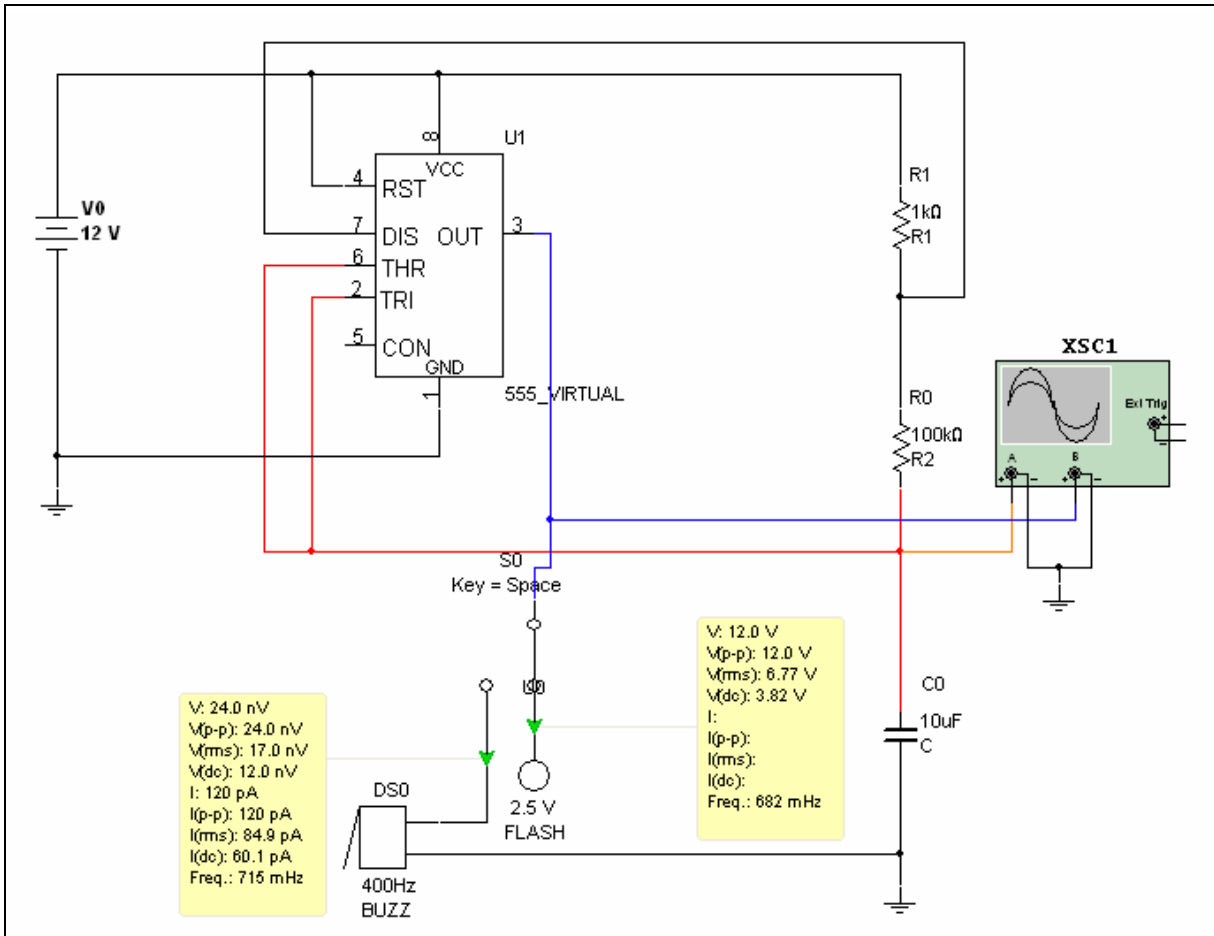

Figure 8-1 555Astab.ms10

Relevant Worksheets

“Worksheet 8-1: 555 Timer Astable Oscillator”.

Asynchronous Counter

- This circuit is a 4-bit counter using JK flip-flops
- Readout is shown in both hex and binary
- Timing diagram may be observed on the Logic Analyzer.

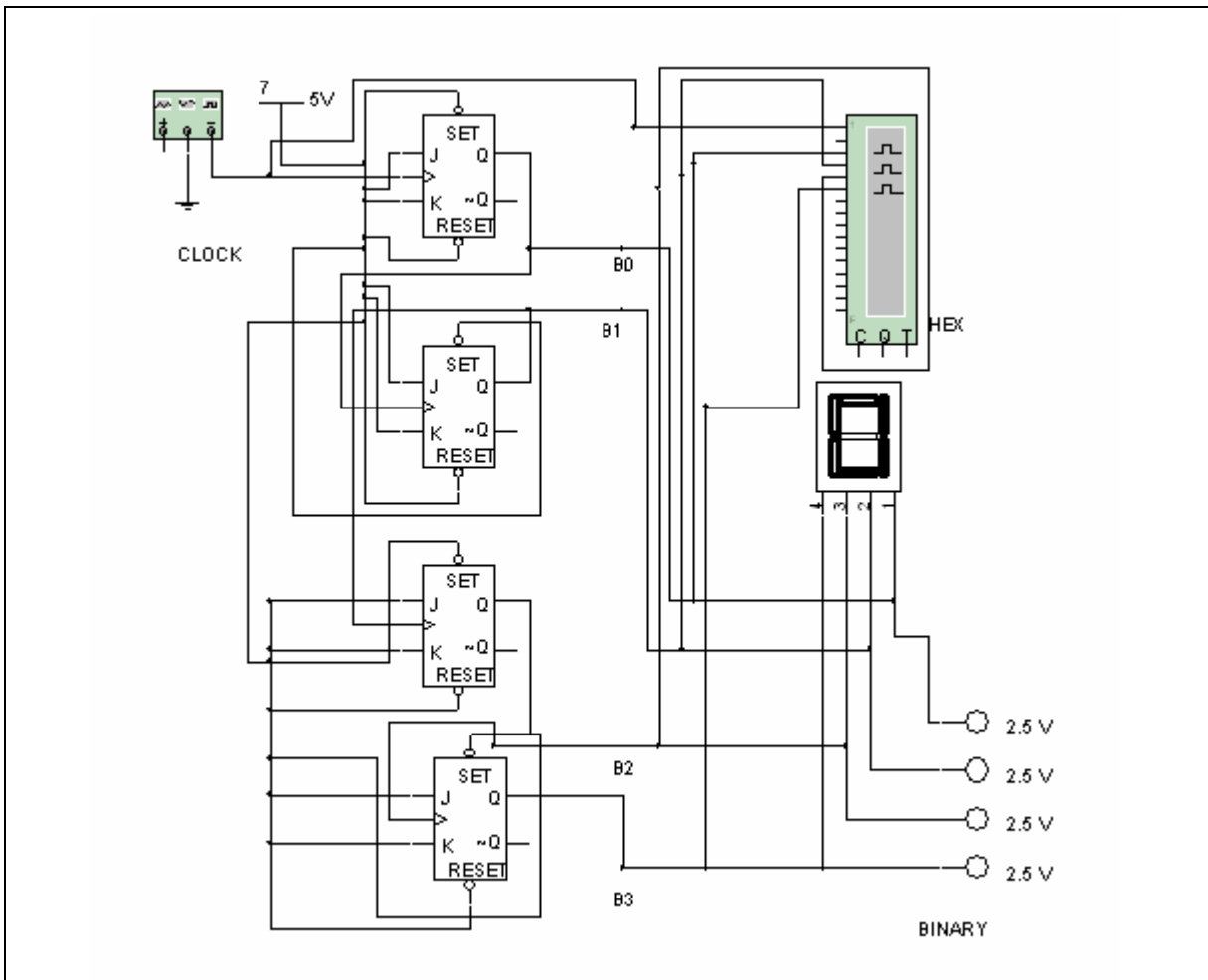

Figure 8-2 AsynchronCounter.ms10

Procedure

1. Solve the circuit and observe the timing of individual outputs on the Logic Analyzer. Specifically, compare the timing between the clock and the four outputs.

References

Topic	Reference
Logic analyzer	Multisim User Guide: Ch. 8 “Instruments”

Demultiplexer

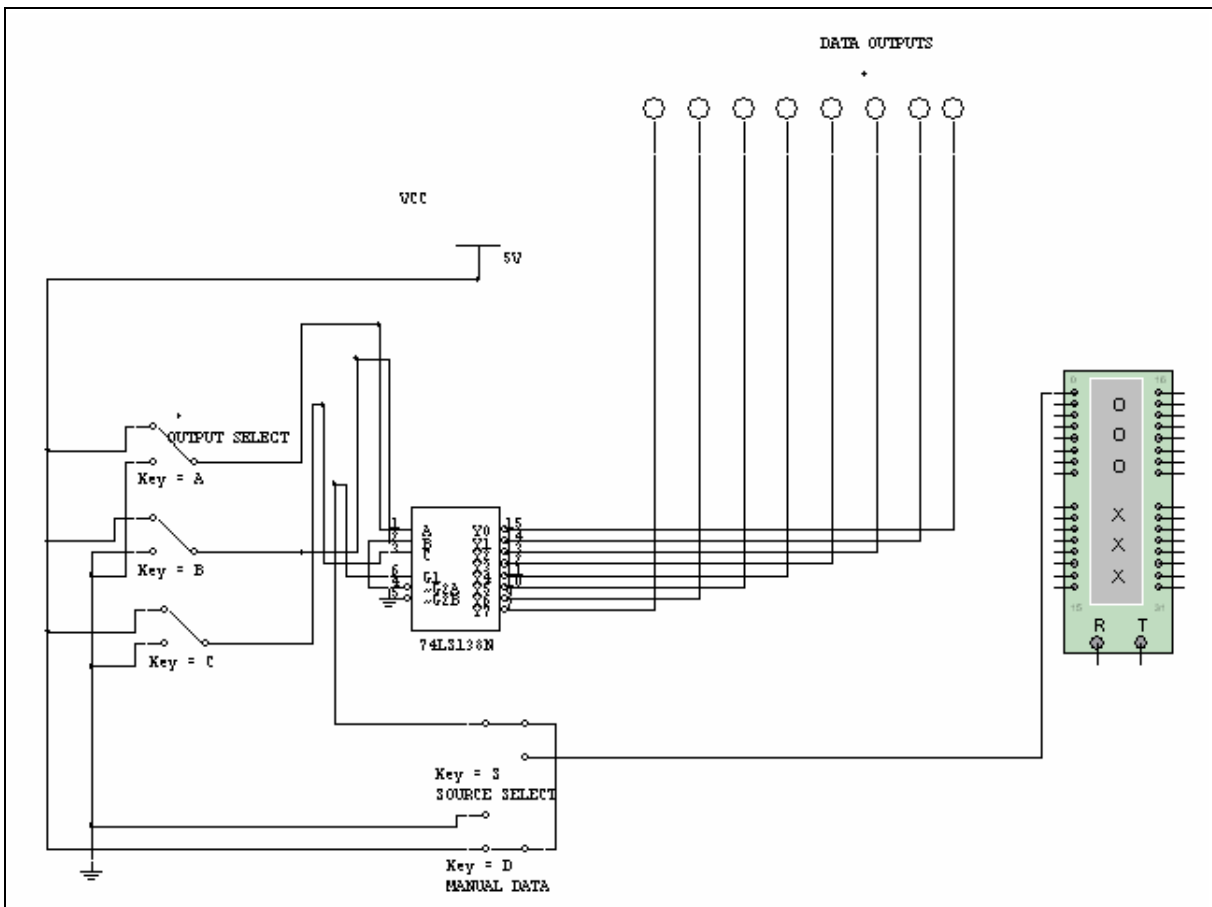

Figure 8-3 Demultiplexer.ms10

Operation

Input data on input line G1 is fed to an output selected by switches A, B and C.

The 74LS138N as a Demultiplexer

- Switches A, B and C select the output fed by input data line G1
- The logic states of output lines 0 to 7 are shown on the data LEDs. Data lines are normally in the high state (called the idle or mark condition in data communications) when no data is present
- The source for input data may be input manually or from a pattern stored in the Word Generator, depending on the position of switch S
- Manual data entry is controlled by switch D.

Procedure

1. Open file **Demultiplexer.ms10**.
2. Select manual data entry with switch S. Set data line select switches A, B and C to select output line 5.
3. Solve the circuit and operate the manual data switch D to change the data state and observe the LED on data line 5. Check that the state of data LED 5 corresponds with the state entered by data switch D.
4. Set data line select switches A, B and C to select any other output line and confirm that correct data appears corresponding to data switch D.
5. Select the Word Generator as data source with switch S. Check the data pattern in the Word Generator and select CYCLE on the Word Generator. This will provide a constant stream of data as an input.
6. Confirm that the pattern in the Word Generator is appearing on the correct data output.
7. Experiment by changing the data pattern in the Word Generator and sending this pattern to a selected output.
8. Write a brief report summarizing the results of this investigation.

Relevant Worksheets

- “Worksheet 8-2: Digital Circuit Example 1”
- “Worksheet 8-3: Digital Circuit Example 2”
- “Worksheet 8-4: Digital Circuit Example 3”
- “Worksheet 8-5: Digital Circuit Example 4”.

References

Topic	Page
Word generator	Multisim User Guide: Ch. 8 “Instruments”
Logic converter	Multisim User Guide: Ch. 8 “Instruments”
Boolean expression	Multisim User Guide: Ch. 8 “Instruments”
Truth table	Multisim User Guide: Ch. 8 “Instruments”

Synchronous BCD Counter Using Discrete Elements

Comments

- The complete timing diagram is shown on the Logic Analyzer
- BCD output is shown on the 7-segment display.

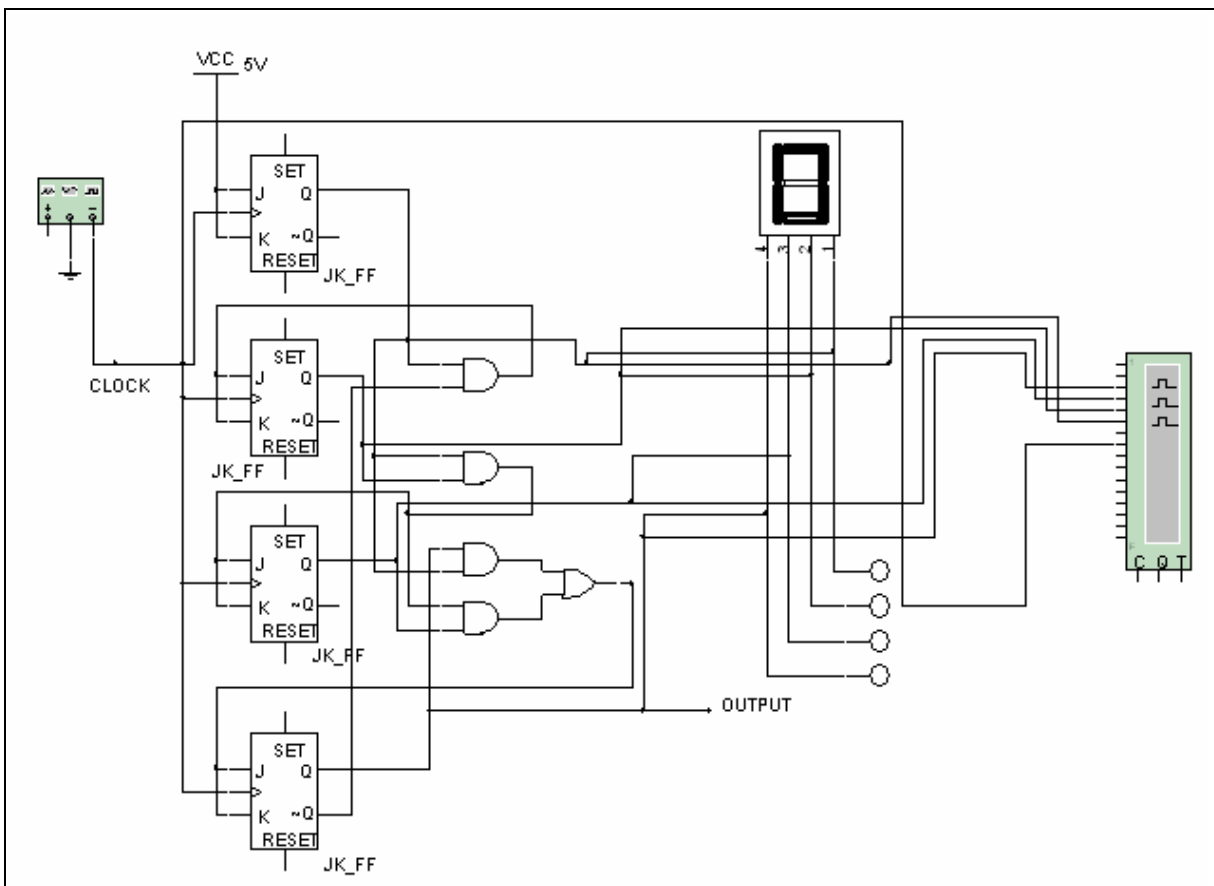

Figure 8-4 SynchronCounter.ms10

Procedure

1. Open file **SynchronCounter.ms10**.

2. Solve the circuit and observe the timing of individual outputs on the Logic Analyzer. Specifically, compare the timing between the clock and the four outputs.

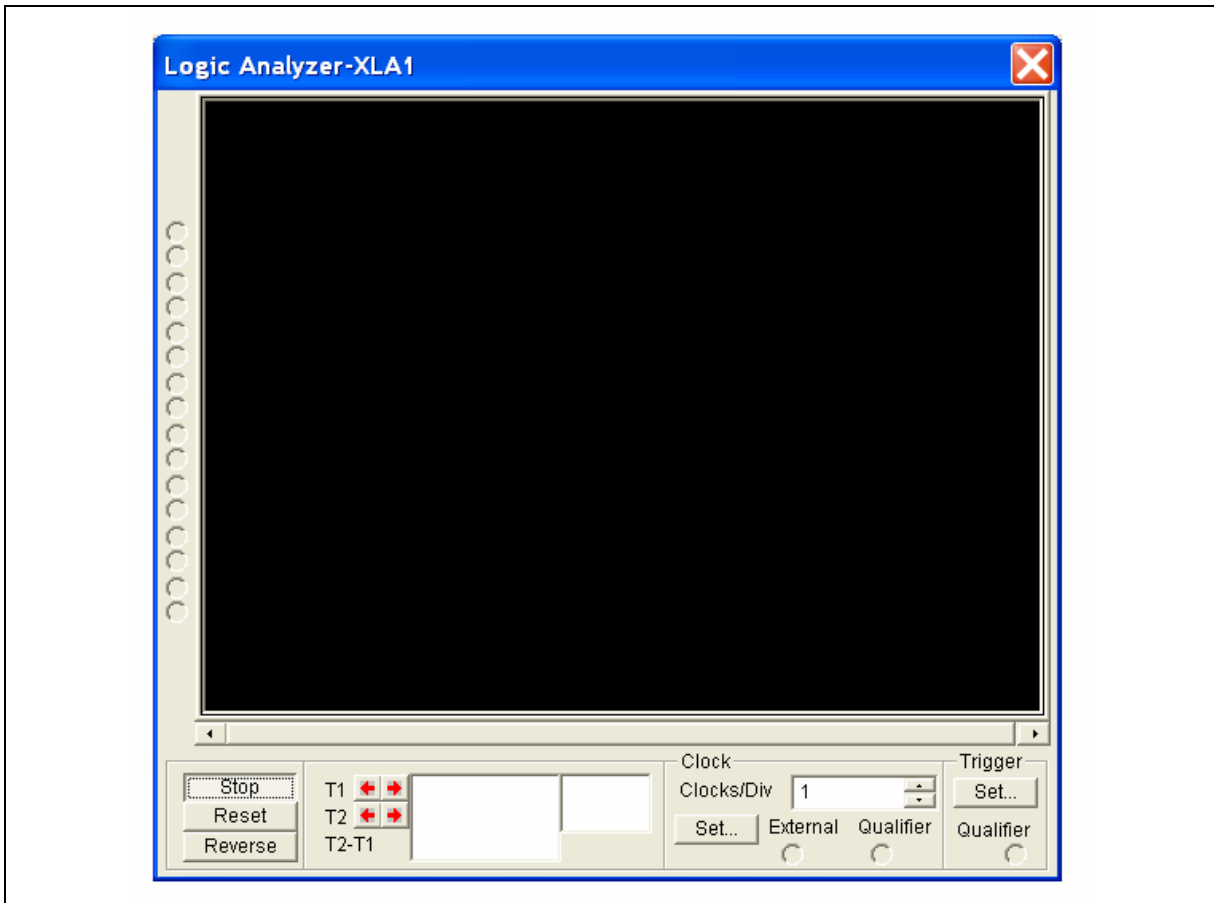

Figure 8-5 Logic Analyzer

References

Topic	Page
Logic analyzer	Multisim User Guide: Ch. 8 “Instruments”

Worksheet 8-1: 555 Timer Astable Oscillator and Wizard

Name: _____ ID Number: _____ Class: _____

Starting Point

Open file **555Astab.ms10**.

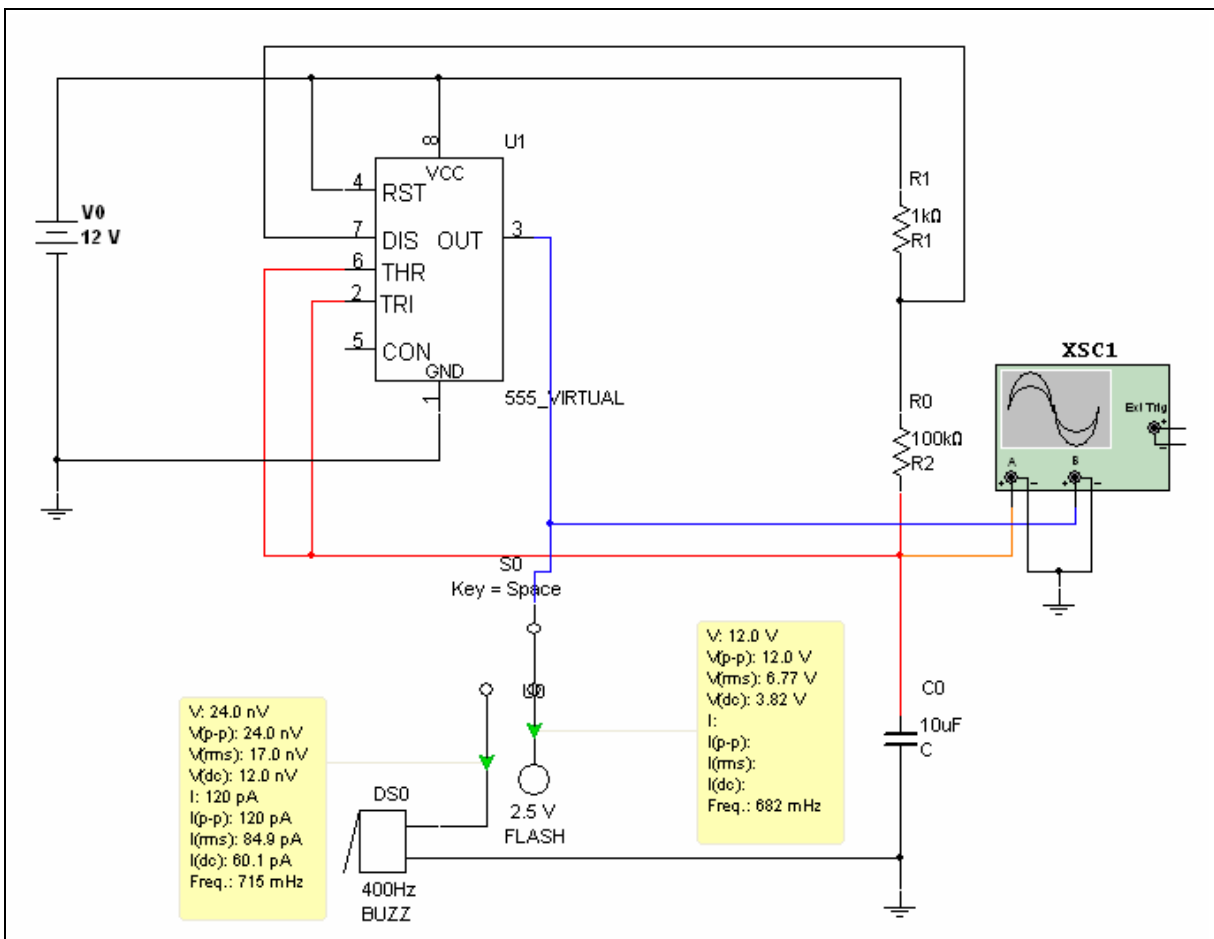

Questions

1. For the circuit shown, calculate the value of upper and lower thresholds. Show calculations.

$$V(ut) =$$

$$V(lt) =$$

2. Calculate the time required for the capacitor to charge from $V(lt)$ to $V(ut)$. Show calculations.

$$t1 = \text{_____} \text{sec.}$$

3. Calculate the time required for the capacitor to discharge from $V(ut)$ to $V(lt)$. Show calculations.

$$t2 = \text{_____} \text{sec.}$$

4. Calculate the frequency of oscillation.

5. Calculate the duty cycle of the output waveform.

6. Repeat the above calculations for steps 1 through 4 with $R1$ changed to 33 kohms.

10. Measure all calculated parameters.

- a) Which waveform shows the upper and lower threshold voltages (output or across C)? Explain.

Measured $V(t)$ =

$V(ut)$ =

- b) Which waveform shows the charging and discharging time for the capacitor (output or across C)? Explain.

Measured t_1 =

t_2 =

- c) Measured frequency of oscillation. Show calculations.

$f(\text{osc}) = \underline{\hspace{2cm}}$ Hz

- d) How does this compare with your rough estimate from step 7?

- e) Measured duty cycle. Show calculations.

Duty cycle = $\underline{\hspace{2cm}}$ %

11. Change R1 to 33k and repeat measurements of 10 a) through 10 d). Show measurements and calculations where appropriate.

a) Measured $V(t)$ = _____ v.

b) $V(ut)$ = _____ v.

c) Measured $t1$ = _____ sec. $t2$ = _____ sec.

d) $f(\text{osc})$ = _____ Hz

e) Duty cycle = _____ %

12. Change R1 to 1k and connect a 10k resistor from pin 5, the Control pin, to ground.

a) Predict the effect on frequency and duty cycle and explain your prediction briefly.

Frequency will _____

Explanation:

Duty cycle will _____

Explanation:

b) Solve the circuit, measure frequency and duty cycle and compare with your predictions. If there are major differences, explain.

Freq. _____ Hz

Duty cycle _____ %

13. Select **Tools/Circuit Wizards/555 Timer Wizard** from the main menu. Select $V_s = 10V$ and frequency = 2 kHz. Select Build Circuit and place your circuit in the workspace. Select an Oscilloscope from the Instruments toolbar. Connect the Oscilloscope to the output of the 555 timer, run the simulation and verify your settings.

NI ELVIS Exercise

Starting Point

Create the circuit shown in **555Astab.ms10** on your NI ELVIS breadboard as shown below. This circuit shows the operation of the 555 Timer Astable Oscillator.

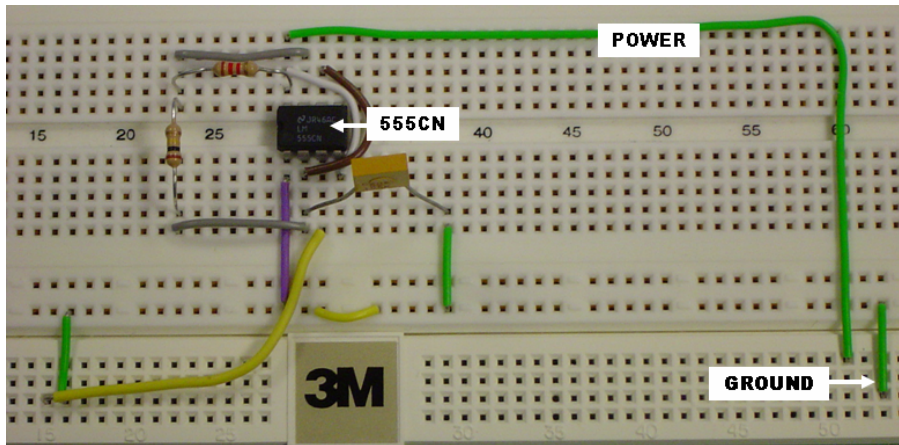

Questions

1. Run the Oscilloscope in NI ELVIS and then open **555Astab.ms10** and run that simulation. Compare your results in the simulation and the NI ELVIS Oscillator.
2. What frequency do you see on the output of your circuit?
3. What amplitude do you see on the output of the circuit?

Worksheet 8-2: Digital Circuit Example 1

Name: _____ ID Number: _____ Class: _____

Starting Point

Open the file **Dig1.ms10**.

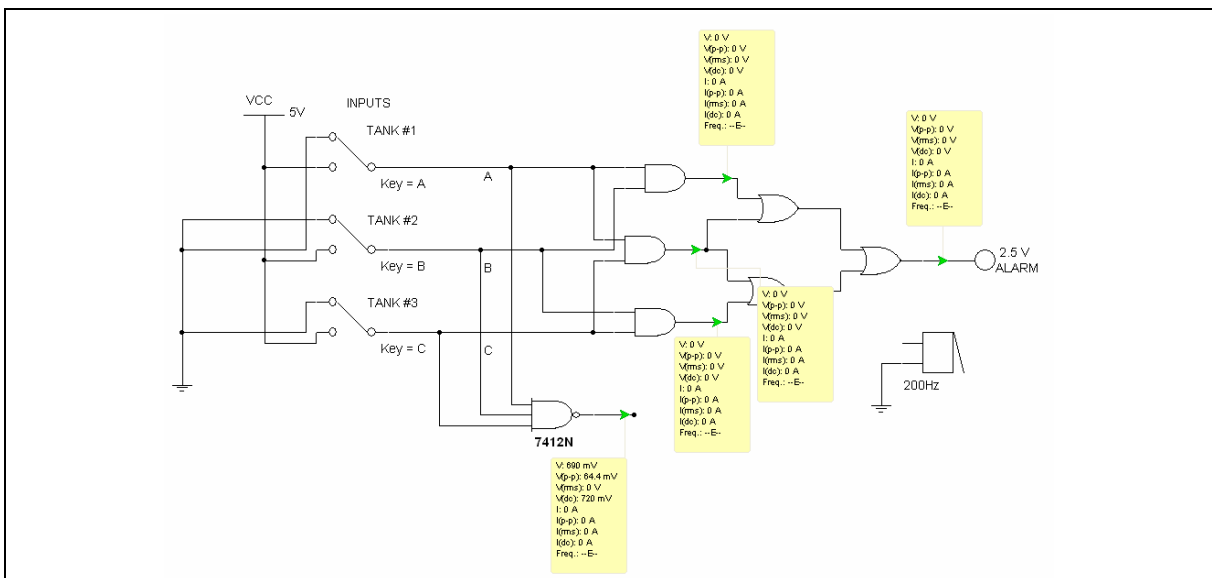

Notes

If two or more Tank inputs (A, B or C) are *high*, then the ALARM indicator should light. That is, its output state is high, or logic 1. To change a switch, press its key designation denoted above. If an audible alarm is desired, the piezoelectric buzzer may be connected to the output.

Circuit Evaluation

Manual evaluation of a truth table using switched to control logic inputs.

1. This circuit has three inputs. How many possible combinations of inputs are there?

Questions

1. Any Boolean function can be represented using only NAND gates, only NOR gates, or a combination of AND, OR, and NOT gates since these are functionally complete. In the table below, show how each of a NOT, AND, OR, and NOR gate can be replaced using only NAND gates.

	Draw the Gate	Draw the NAND Equivalent
NOT		
AND		
OR		
NOR		

2. In the space below, build a Karnaugh map that coincides with the truth table in step 2 of the circuit evaluation section of this worksheet.

3. A Boolean equation describes the timing of a logic circuit.

True or false? _____

Explain _____

Worksheet 8-3: Digital Circuit Example 2

Name: _____ ID Number: _____ Class: _____

Starting Point

Open file **Dig1A.ms10**.

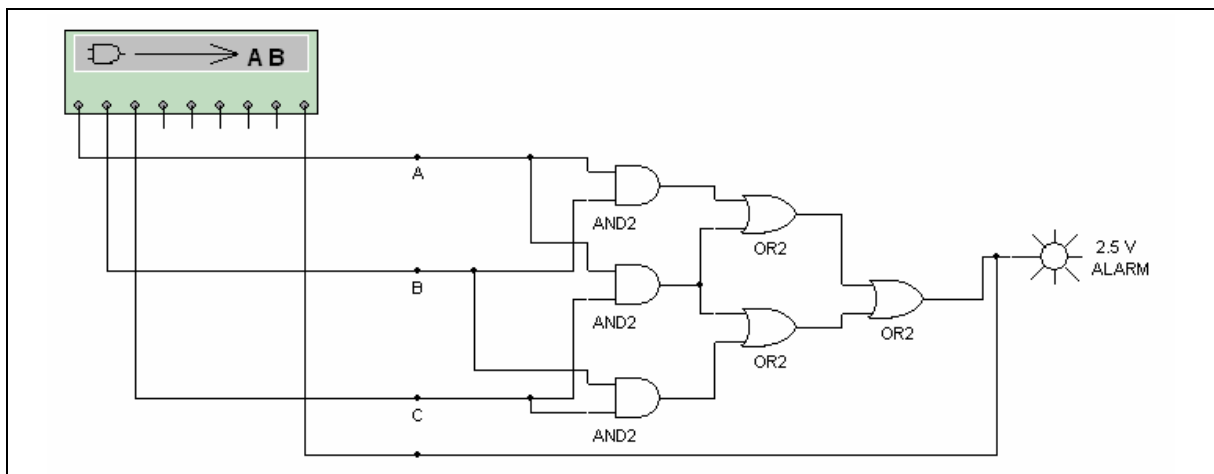

Notes

If any two (or more) of inputs A, B or C are high, then the ALARM indicator should light. (That is, its output state is high, or logic 1.)

Circuit Evaluation

Using the Logic Converter

The logic converter provides all possible logic states to as many as eight inputs and indicates the state of a single output. For this circuit, only three inputs are necessary.

Questions

1. Solve the circuit and select (click on) the first Conversions button in the open Logic Converter. This produces the truth table for the circuit. Record the truth table solution.

A	B	C	Output

2. Select (click on) the second Conversions button. This provides a Boolean expression for the circuit. Record the Boolean expression.
3. Confirm, by logic analysis of the circuit, that the answers provided by the Logic Converter are correct. Show all work.

Truth Table:

Boolean expression:

Worksheet 8-4: Digital Circuit Example 3

Name: _____ ID Number: _____ Class: _____

Starting Point

Open file **Dig1B.ms10**.

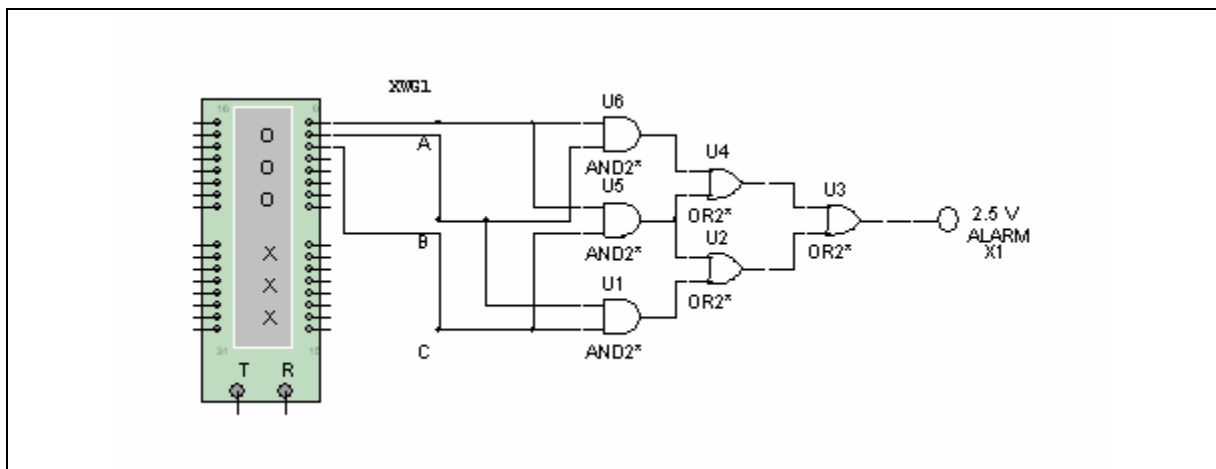

Notes

If any two (or more) of inputs A, B or C are *high*, then the ALARM indicator should light. (That is, its output state is high, or logic 1.)

As the input is stepped through all eight possible digital states, complete the truth table for the circuit.

A	B	C	Output

4. Confirm, by logic analysis of the circuit, that the answers provided by the Logic Converter are correct. Show all work.

Truth Table

Worksheet 8-5: Digital Circuit Example 4

Name: _____ ID Number: _____ Class: _____

Starting Point

Open file **Dig1C.ms10**.

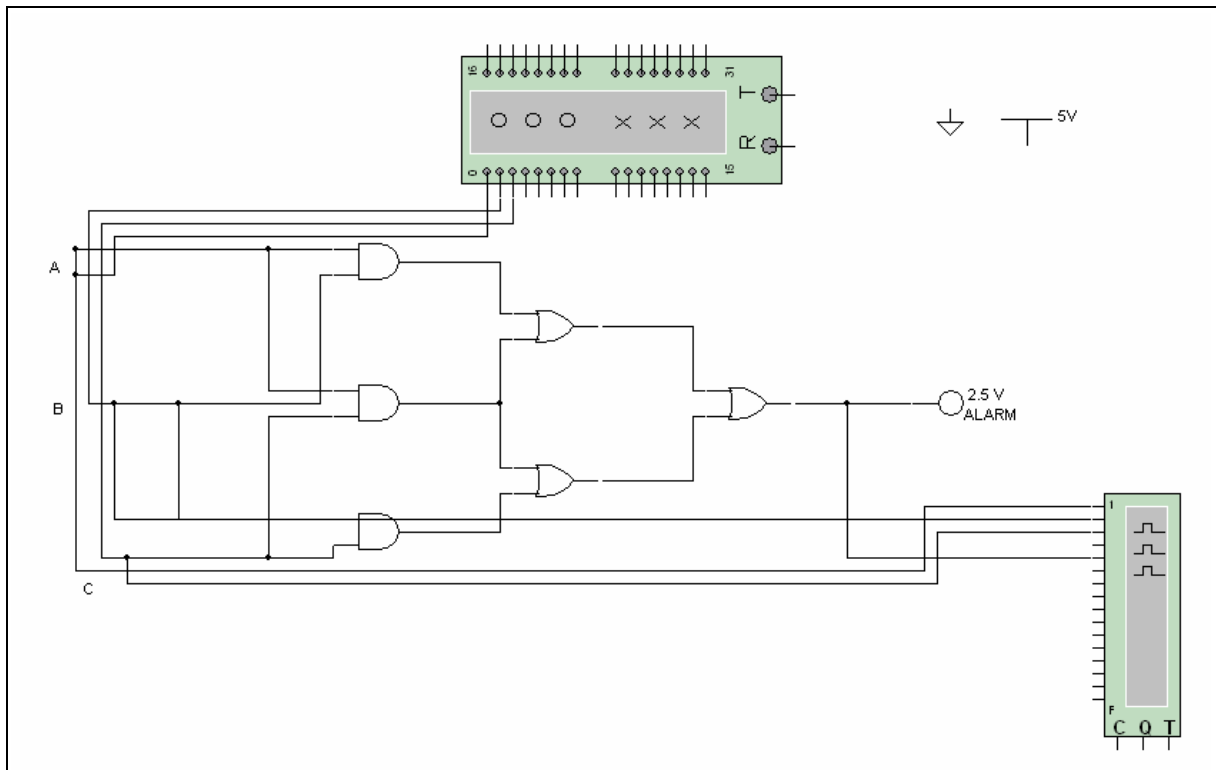

Notes

If any two (or more) of inputs A, B or C are *high*, then the ALARM indicator should light. (That is, its output state is high, or logic 1.)

2. Select a similar circuit from your digital text, analyze this circuit using the test equipment and methods investigated in the Dig1 series of circuit files and submit a brief but complete report on your investigations, including a printout of the circuit and solutions.

Section 9: Analog and Digital Combinations

Section Contents

This section contains the following:

- “Introducing Mixed Circuits” on page 9-2
- “Processing Analog Input to Digital and Back” on page 9-3.

Worksheets in this Section

The worksheets in this section start on page 1 of Worksheet 9-1:

- “Worksheet 9-1: Analog to Digital Conversion (ADC)”
- “Worksheet 9-2: Digital to Analog Conversion (DAC)”.

Circuits for this Section

The following is a list of the file names of circuits used in this section and a brief description of each.

File (.ms10)	Description
ADC-DAC	A complete A/D and D/A circuit sampling; reconstructing a sine wave.
AnalogToDigital Converter	The Analog to Digital Converter.
DigitalToAnalog Converter	The Digital to Analog Converter.

Introducing Mixed Circuits

In order to analyze control system technology, students must have exposure to combinations of analog and digital circuitry. Multisim provides these combinations in its simulated environment.

The circuit files presented in this section include analog to digital conversion, digital to analog conversion and analog to digital then back to analog conversion. The sample files, **AnalogToDigitalConverter.ms10**, **DigitalToAnalogConverter.ms10** and **ADC-DAC.ms10** may be modified to better suit your individual course requirements. **DigitalToAnalogConverter.ms10** uses Multisim's Bus feature to make some of the wiring connections automatically before the circuit is completed. A worksheet is provided for each file.

Goals

- to provide examples of digital and analog combined circuitry in a Multisim environment
- to introduce the 7-segment BCD display and the LED indicator.

Prerequisites

You will need the following circuit files:

- **AnalogToDigitalConverter.ms10**
- **DigitalToAnalogConverter.ms10**
- **ADC-DAC.ms10**.

Students are expected to have:

- A basic introduction of the operation of analog to digital to analog converters
- A familiarity with the Multisim environment including the use of assorted analog and digital test equipment.

Relevant Worksheets

- “Worksheet 9-1: Analog to Digital Conversion (ADC)”
- “Worksheet 9-2: Digital to Analog Conversion (DAC)”.

Processing Analog Input to Digital and Back

Application

This is similar to, but simpler than, circuits used for digital recording and playback for audio tape, CDs and video.

Prerequisites

You will need file **ADC-DAC.ms10**.

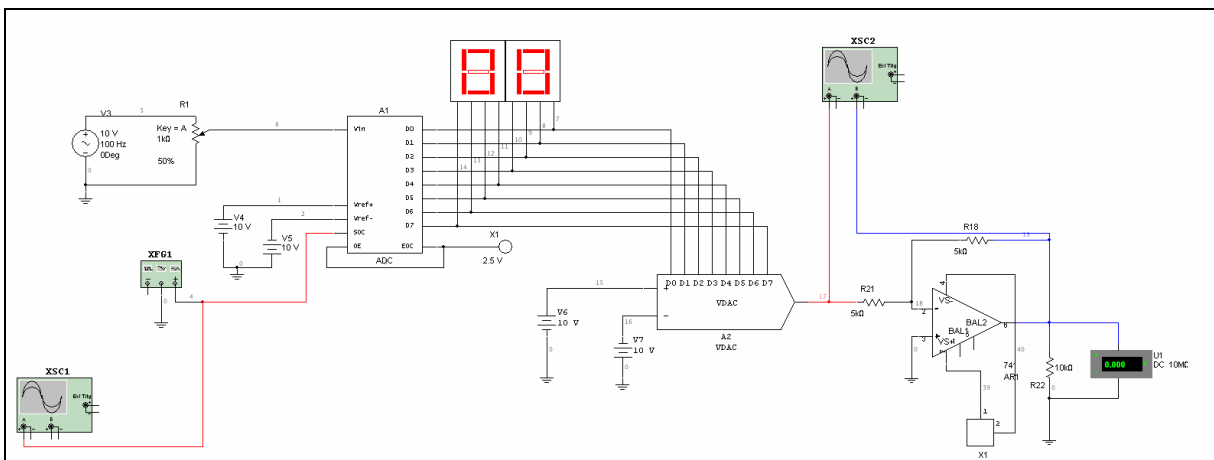

Figure 9-1: ADC-DAC.ms10

Operation

- The Function Generator drives the SOC (start of conversion) and the rate at which the input analog signal is sampled
- The digital value is shown (in hexadecimal) on the two 7-segment displays and fed to the Digital to Analog converter for conversion back to analog.

Procedure

1. Open file **ADC-DAC.ms10**.
2. With input potentiometer at 50%, calculate the value of the peak-to-peak analog input voltage. (Show calculations.)

$$V(\text{in}) = \text{_____} v(\text{p-p})$$

3. Set the sample rate (Function Generator) to 1 kHz.
4. For an input frequency of 100 Hz, calculate the number of samples which will be taken of each input cycle.
No. of samples = _____
5. Make a rough sketch, to time and amplitude scale, of the output waveform that will be expected.

6. Set the sample rate and input frequency to the values used above and solve the circuit.
7. Sketch the output waveform.

8. Comment on the relationship between predicted and measured output.

- Experiment with this A-D and D-A process by changing the sample rate. (Leave input frequency and amplitude as-is.) Comment on the relationship between sample rate and "distortion" of the output waveform.

NI ELVIS Exercise

Starting Point

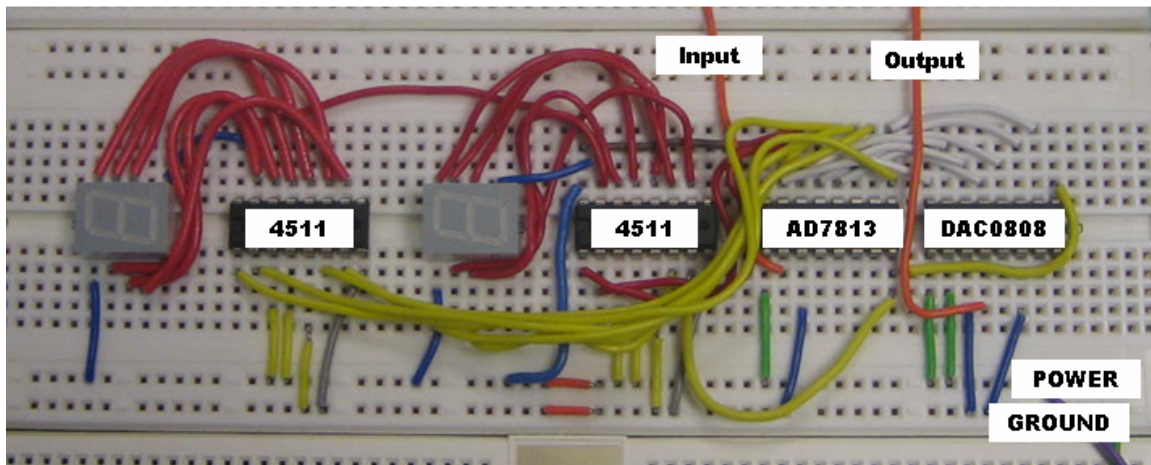

Create the circuit shown in **ADC-DAC.ms10**. There are many wires that connect to the ADC chip, so use caution when connecting everything to this chip. Pay special attention to the order of the bits and which of the 7-segment display driver chips you're connecting them to.

Questions

There is one input and one output to this circuit. The voltage you use as an input should be seen on the output wire since you are converting your input into digital and then converting that digital value back to an analog value.

One thing you will notice in your output is stepping caused by the fact that your digital signal has a set resolution. What size will the steps be? What could you do to decrease the size of the steps (a.k.a. increasing your resolution)?

Worksheet 9-1: Analog to Digital Conversion (ADC)

Name: _____ ID Number: _____ Class: _____

Starting Point

Open file **AnalogToDigitalConverter.ms10**.

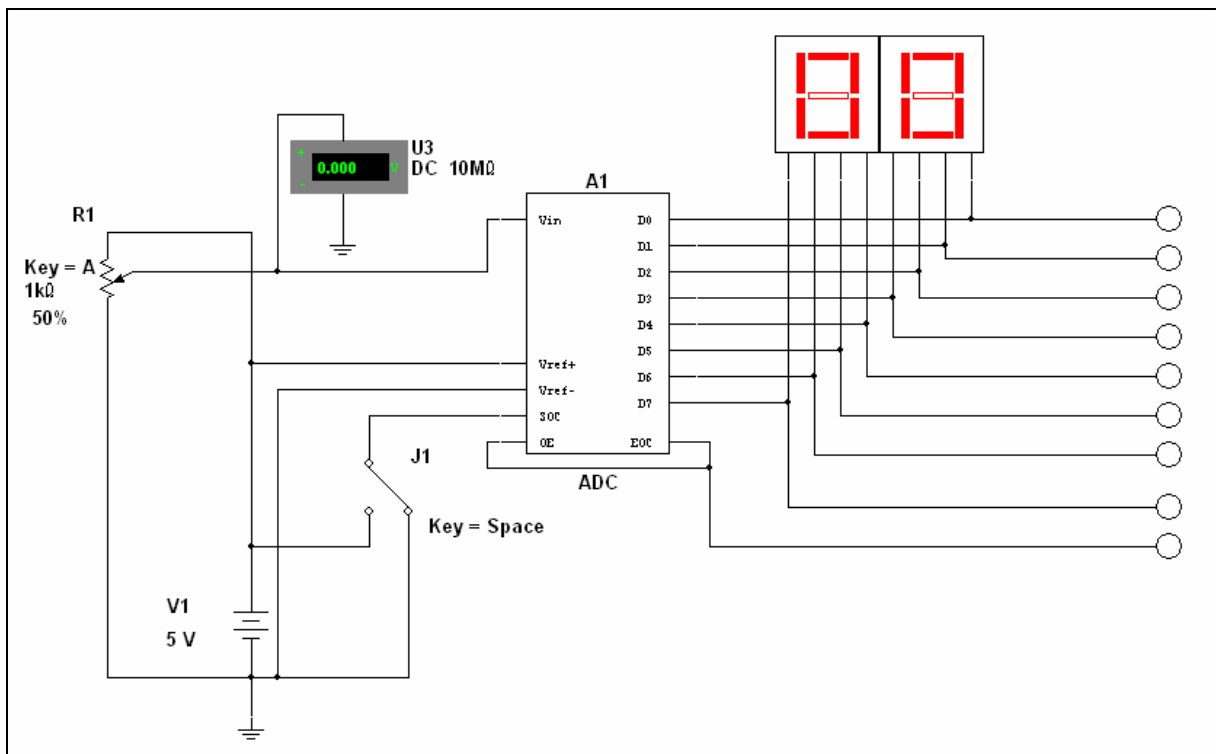

3. Calculate the possible error to be expected for this A/D converter.

4. Make sure the SOC terminal is connected to Vcc (+5 V). Solve the circuit.

5. What is the digital output in hex?
 - a) Calculate the analog input voltage. Show calculations.

$$V_{in} = \text{_____ V}$$

- b) The setting of the input potentiometer is _____%. From the pot setting, calculate the analog input voltage.

$$V_{in} = \text{_____ V}$$

- c) Compare the two readings. Are they within the expected error calculated above?

- d) What is the input Voltmeter reading?
6. How do the calculated readings above compare with the reading of the Voltmeter? Comment.
7. Take several more readings for inputs at or below 1.0 V and above 4.0 V. Record all readings, including the Voltmeter, and calculate the input voltages. Comment on the accuracy of the A/D converter compared to the analog Voltmeter.

Worksheet 9-2: Digital to Analog Conversion (DAC)

Name: _____ ID Number: _____ Class: _____

Starting Point

Open file **DigitalToAnalogConverter.ms10**.

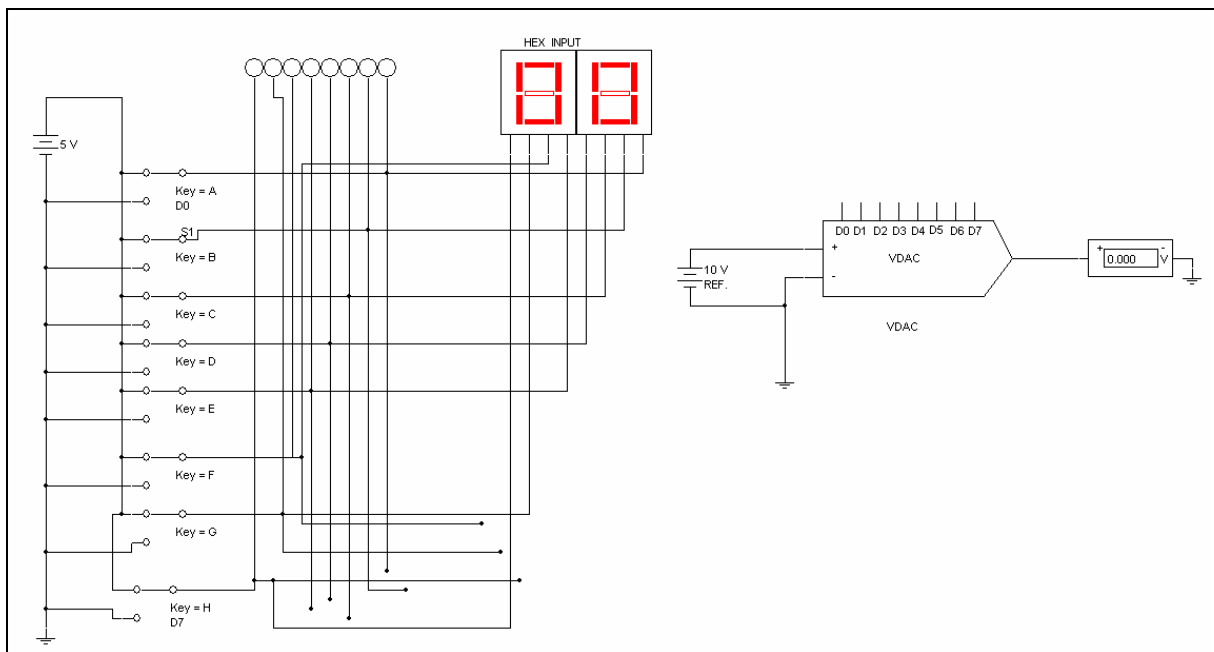

Notes

- V_{in} is set by switches A through H and is shown in both hex and binary
- The conversion reference is 10 V.

Before you begin this part of the lab you must place a bus in the workspace and make the appropriate connections to it. To do this, select **Place/Bus** from the main menu. Left-click on the workspace directly above the VADC IC. Drag the bus horizontally across until it is exactly parallel to the VADC and double-click. Highlight the VADC by left-clicking on it. Select **Place/Bus Vector Connect** to make the connections. The **Bus Vector Connect** dialog will appear. Highlight D0-D7 by highlighting D0 then pressing SHIFT-D7. Click the left down-arrow key to place all selected pins to the lower-left field in the Bus **Bus Vector Connect** dialog box. Select Bus1 then click **Auto-assign**. Click **OK** to close the dialog; the connections to the bus are made automatically. Click on each wire and change the color according to the list provided in the Circuit Description Box.

Click on each color-coded wire and connect them to the appropriate bus connection according to the following list: D0 connect to dark green; D1 connect to baby blue; D2 connect to brown; D3 connect to pink; D4 connect to light green; D5 connect to blue; D6 connect to yellow; D7 connect to red

Run the simulation by clicking on the switch or selecting **Simulate/Run** from the main menu.

Questions

1. This is an 8-bit D/A converter. With a reference voltage of 10 V, what voltage does each bit represent in terms of the analog output? Show calculations.
2. If the output is 3.62 V, what is the value of the digital input? Show calculations.
3. Calculate the possible conversion error to be expected for this D/A converter.
4. Comment on the relationship between reference voltage and accuracy of conversion.

Procedure

1. Open file **DigitalToAnalogConverter.ms10**.
2. Set the digital input to 38 in hex. Solve the circuit. Analog output is _____ V.
 - a) For the digital input used, calculate the analog outputs possible, considering the conversion accuracy calculated above (up to three possible). Show calculations.

$$V_{out} = \text{_____ V}$$

Or

$$V_{out} = \text{_____ V}$$

Or

$$V_{out} = \text{_____ V}$$

- b) Is the output reading within the expected error calculated above?
3. Take several more readings for inputs at or below 0F (hex) and above C0 (hex). Record all readings.
 4. Comment on the accuracy of the D/A converter.
 5. Change the reference voltage to 5 V, make several readings as in step 2 and comment on the effect of reference voltage on conversion accuracy.

Section 10: Radio Frequency Communication

Section Contents

This section contains the following:

- “Introducing Radio Frequency” on page 10-2
- “RF Amplifier with Thermal Noise Source” on page 10-4.

Worksheets in this section

The worksheets in this section start on page 1 of Worksheet 10-1:

- “Worksheet 10-1: Spectral Analysis Introduction”
- “Worksheet 10-2: AM Introduction”
- “Worksheet 10-3: Envelope Detector with Agilent Function Generator”
- “Worksheet 10-4: FM Introduction”.

Circuits for this Section

The following is a list of the file names of circuits used in this section and a brief description of each.

File (.ms10)	Description
AMIntroduction	A file which contains two circuits, Circuit A and Circuit B. Circuit A is a demonstration of the basic concept of amplitude modulation. Circuit B is a circuit that demonstrates Multisim’s AM Modulator.
EnvDetectorWithAgilentFG	A file which contains an Envelope Detector driven by the Amplitude Modulation feature on the Agilent Function Generator.
FMIntroduction	A circuit which demonstrates Multisim’s FM Modulator.
RFampWithThermalNoiseSource	A file which introduces students to RF Amplification and noise generation.
SpectrumAnalyzerIntro	A file which introduces students to Multisim’s Spectrum Analyzer.

Introducing Radio Frequency

Multisim contains numerous features which apply to radio frequency electronics in particular.

Some of these include high frequency components, transmission lines, waveguides and instruments like the Spectrum Analyzer and the Network Analyzer. An amplitude modulation and a frequency modulation module are available to users and are used in this section.

The Spectrum Analyzer will be introduced in this section as well as AM and FM transmission. The student is asked to observe an AM and an FM waveform on both the Oscilloscope and the Spectrum Analyzer.

Circuit files **SpectrumAnalyzerIntro.ms10**, **AMIntroduction.ms10**, **EnvDetectorWithAgilentFG.ms10** and **FMIntroduction.ms10** will be opened in this section. The file **SpectrumAnalyzerIntro.ms10** contains an explanation of how to use the Spectrum Analyzer in its Description Box.

Goal

To introduce Multisim's AM Modulator, FM Modulator and the Spectrum Analyzer and familiarize the student with their usage.

Prerequisites

Students should:

- Be familiar with the Multisim environment including the Oscilloscope
- Have been introduced to amplitude modulation, frequency modulation and spectral analysis.

Relevant Worksheets

- "Worksheet 10-1: Spectral Analysis Introduction"
- "Worksheet 10-2: AM Introduction"
- "Worksheet 10-3: Envelope Detector with Agilent Function Generator"
- "Worksheet 10-4: FM Introduction".

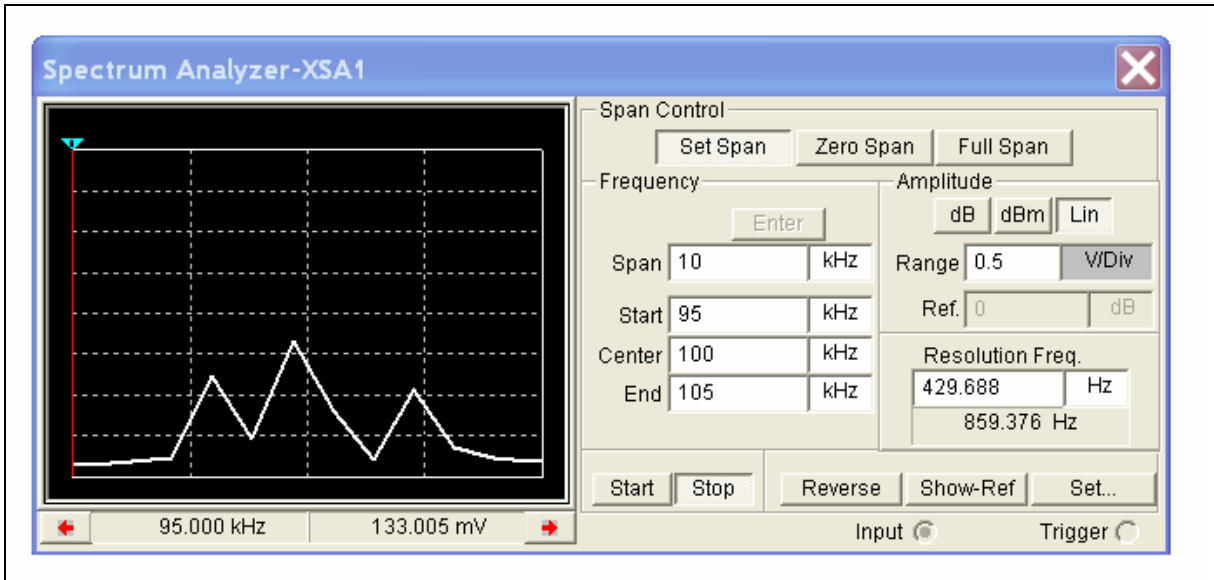

Figure 10-1: The Spectrum Analyzer Window

RF Amplifier with Thermal Noise Source

Goal

To familiarize the student RF circuit analysis and introduce him/her to the concept of noise generation.

Comments

The Thermal Noise Source can be found in the Signal Voltage Sources family in the master database.

Procedure

1. Open **RFampWithThermalNoiseSource.ms10**.
2. Open the Description Box.
3. Run the simulation by clicking on the switch or selecting **Simulate/Run**.

Worksheet 10-1: Spectral Analysis Introduction

Name: _____ ID Number: _____ Class: _____

Starting Point

Open the file **SpectrumAnalyzerIntro.ms10**.

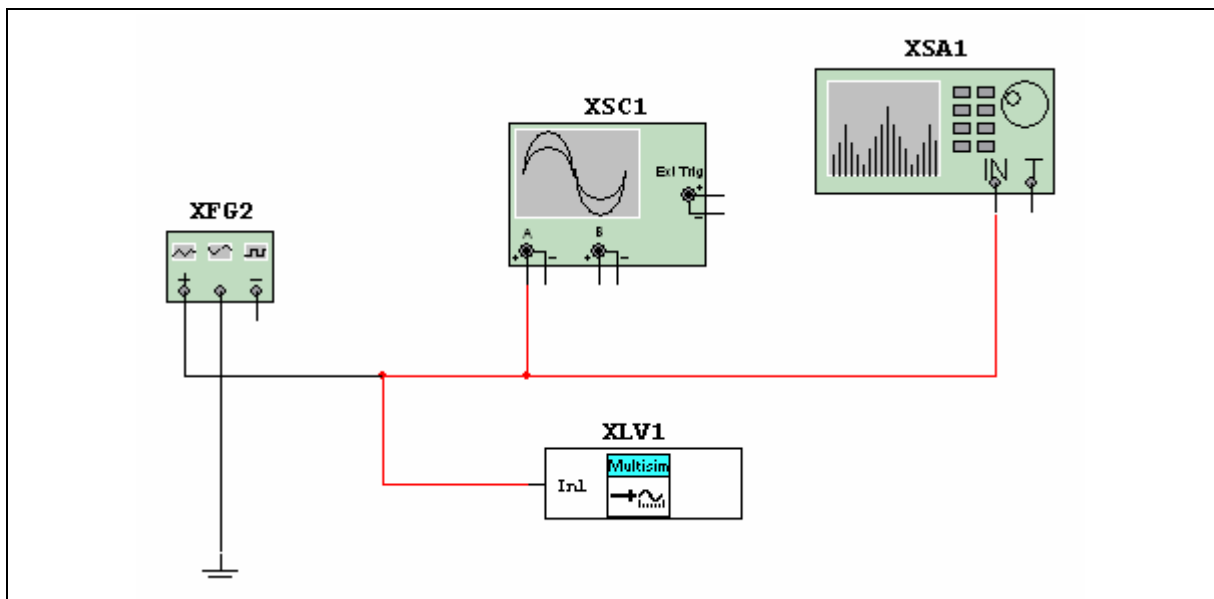

Notes

- This file contains a description on how to set the frequency control settings on the Spectrum Analyzer.
- The student will be asked to change these settings in order to view the harmonics of a squarewave.

Questions

1. Double-click on the Oscilloscope window in order to view its display.
2. Run the simulation by clicking on the switch or selecting **Simulate/Run** from the menu and observe and measure the frequency of the sinewave.

3. Double-click on the Spectrum Analyzer to view its display.

4. Measure the frequency on the Spectrum Analyzer by dragging the red marker and observing the frequency which is to the bottom right of the spectral display. Compare your results with step 2.

5. Double-click on the Function Generator to view its selection window.
6. Select the rectangular waveform and run the simulation again.
Notice the presence of $3f_0$ and $5f_0$. We would like to observe $7f_0$ and $9f_0$. In order to do that, you must adjust the Spectrum Analyzer to display these frequencies. Use the Center and Span settings to do this. Since we would like the 10 kHz spectral line to appear to the left of the window and 9×10 kHz to appear to the far right in the window, it would make sense to set the span (span of frequencies from left to right on the window) to 100 kHz. If we set the Center = 50 kHz, $5f_0$ will appear in the center of the window.
7. Make the changes suggested above, press Enter and then Start.

$f_0 =$

$3f_0 =$

$5f_0 =$

$7f_0 =$

$9f_0 =$

Worksheet 10-2: AM Introduction

Name: _____ ID Number: _____ Class: _____

Starting Point

Open the file **AMIntroduction.ms10**.

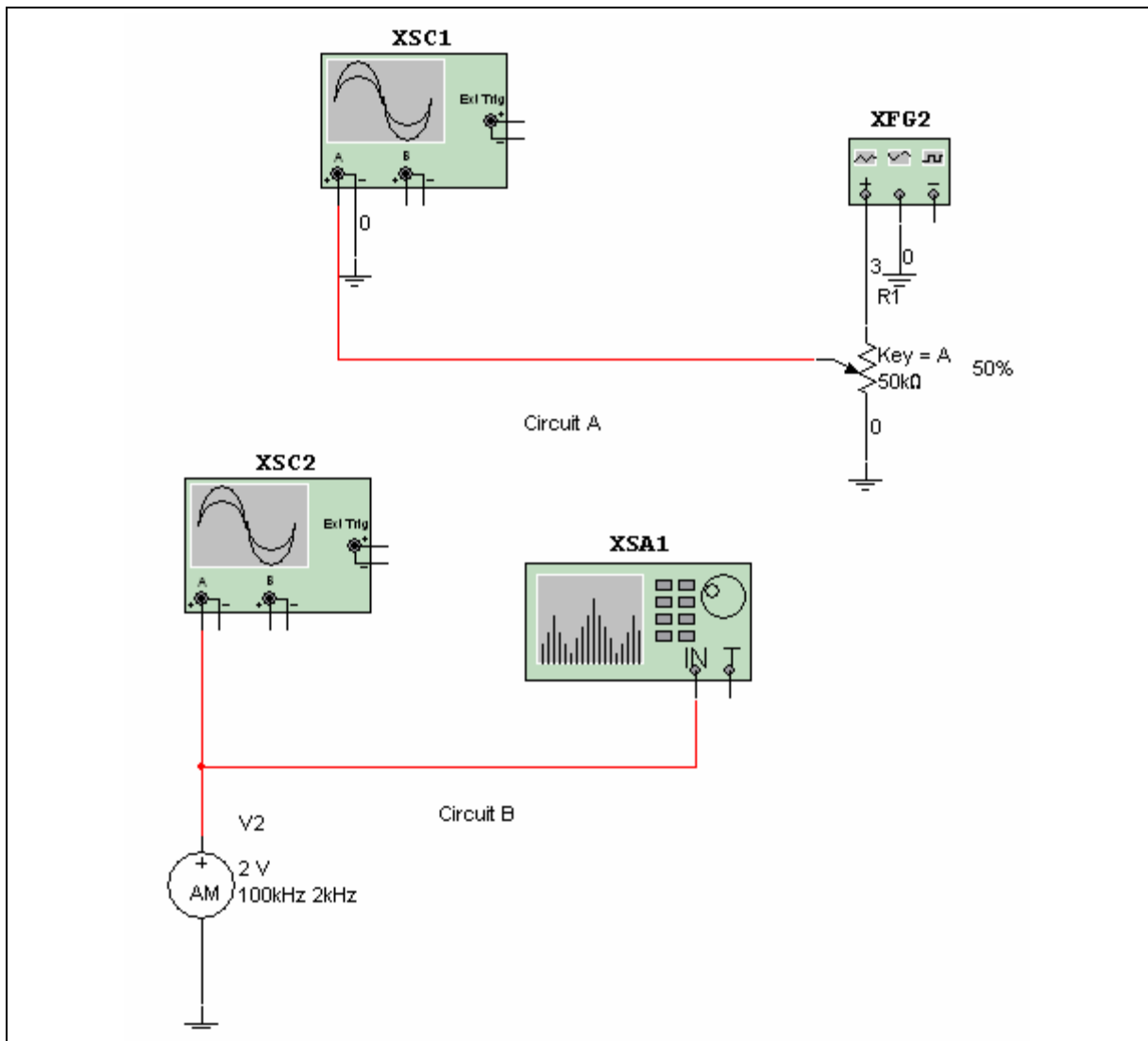

Notes

- This file contains two circuits. Circuit A contains a Function Generator that supplies the carrier frequency and a potentiometer whose adjustment represents the modulating frequency.
- To change the potentiometer, press A to increase its value and SHIFT-A to decrease its value. You can also hover your cursor over the potentiometer and drag the slider bar that appears.

Questions

Circuit A

This circuit is a demonstration of the basic concept of amplitude modulation. The 200 kHz signal from the Function Generator represents the carrier frequency.

1. Double-click on the Oscilloscope to open its window.
2. Run the simulation by pressing the switch or selecting **Simulate/Run** from the menu.
3. Click on the schematic window to activate it then press SHIFT-A quickly several times and observe the effect. Then press A quickly several times and observe the effect. You can also hover your cursor over the potentiometer and drag the slider bar that appears.
4. Describe what you are seeing.

Circuit B

1. Open the Oscilloscope window by double-clicking on it.
2. Run the simulation.
3. Calculate the percentage of modulation using the envelope observed.

4. Double-click on the Spectrum Analyzer. Be patient. It may take several seconds for the spectral display to appear. Measure the frequency of the carrier and the upper and lower sidebands by dragging the red marker to each peak.

5. Observe the frequency noted at the bottom right of the spectral display.

fc =

fupper =

flower =

Worksheet 10-3: Envelope Detector with Agilent Function Generator

Name: _____ ID Number: _____ Class: _____

Starting Point

Open the file **EnvDetectorWithAgilentFG.ms10**.

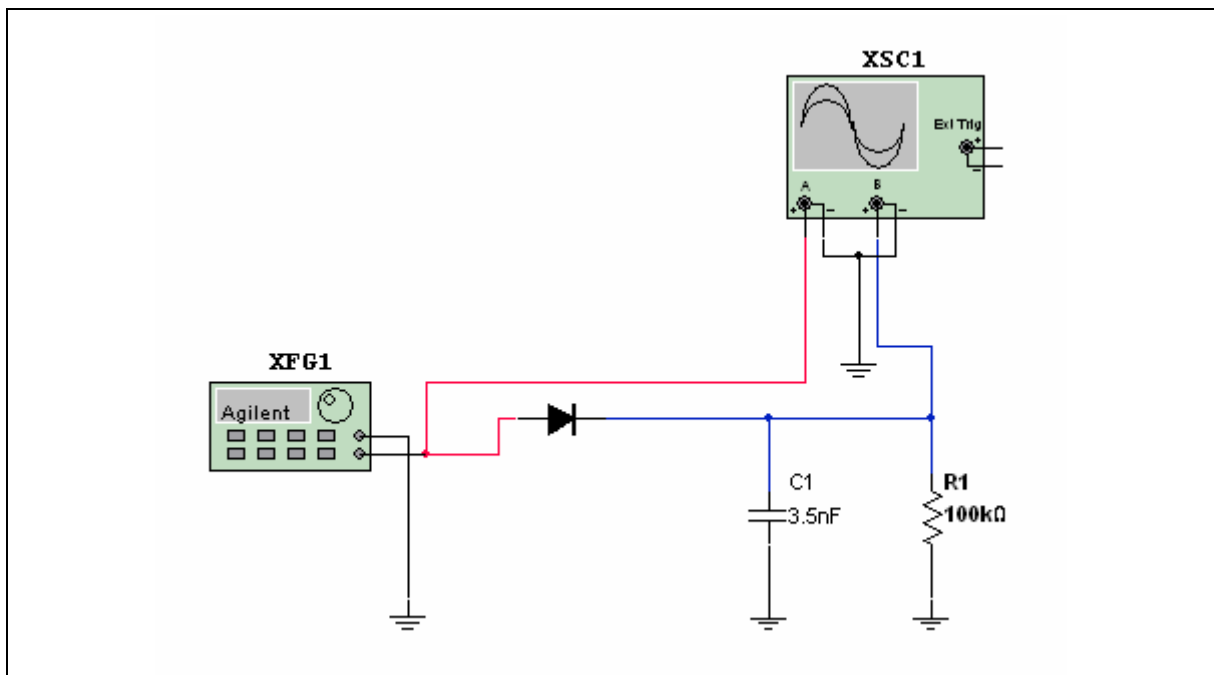

Notes

- See Section 4-2 for further Agilent Function Generator examples.
- This file uses Multisim's Agilent Function Generator to create the AM wave.
- All formulas required are contained within the Circuit Description File.

Questions

The circuit in this file is an Envelope Detector. The Envelope Detector is the easiest way to de-modulate an AM signal. The envelope detector is designed to have a fast charge time and a slow discharge time. R2 controls the discharge time constant.

1. You will use the Amplitude Modulation feature on the Agilent Function generator to produce an AM signal. Double-click on the Agilent Function Generator to open its window. Select Shift then AM. Select Freq. Set the carrier frequency to 100 kHz. Set the amplitude of the carrier signal to 10v by depressing the Ampl button. Set the frequency of the modulating signal to 500 Hz by depressing Shift then Freq. Select 90 % modulation by depressing Shift Ampl and adjusting to 0.9. Open the Oscilloscope window and run the simulation. Record your results by drawing the waveform, labeling each significant point.
2. Re-design the values of R1 and C1 to meet the requirements for $RC = 1/m2\pi fm$. Replace component values by double-clicking on the components.
3. Run the simulation to verify your results.

Worksheet 10-4: FM Introduction

Name: _____ ID Number: _____ Class: _____

Starting Point

Open the file **FMIntroduction.ms10**.

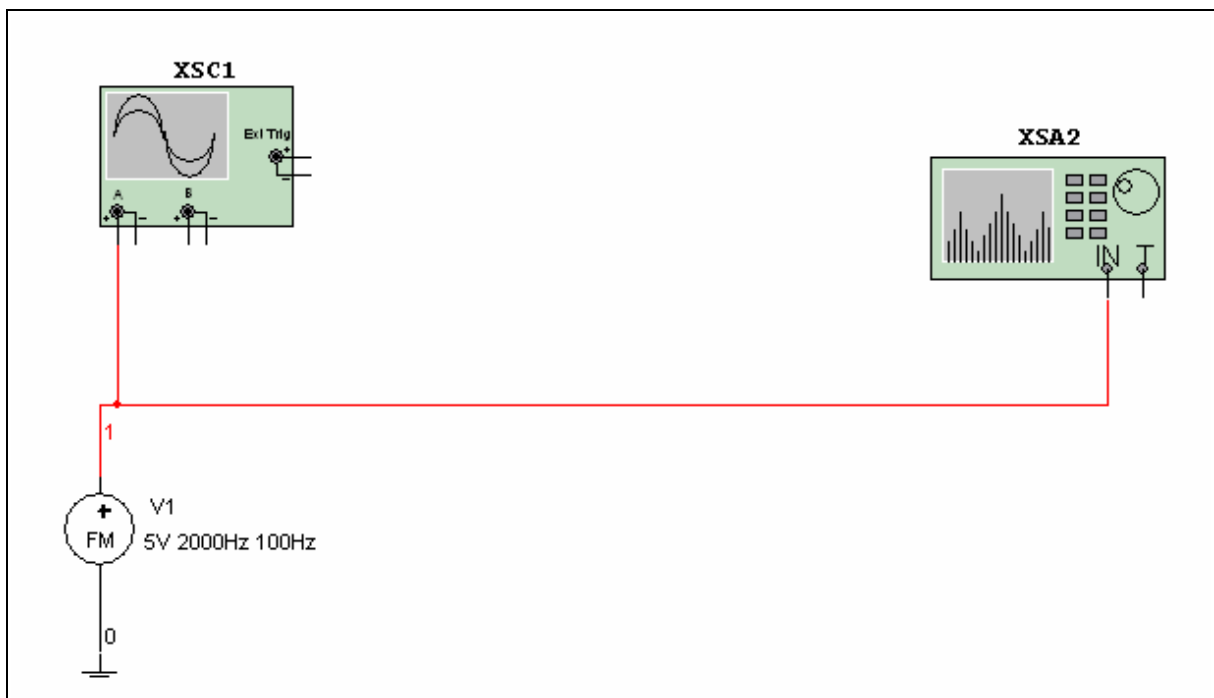

Notes

- The carrier frequency, modulating frequency and modulation index may be changed by double-clicking on the FM Source
- The worksheet is also displayed in the Description Box in the file
- See Spectral Analysis Introduction for a brief overview on how to use the Spectrum Analyzer.

Questions

1. Double-click on the Oscilloscope to view its display.
2. Run the simulation by pressing the switch or selecting **Simulate/Run** from the menu.
3. Observe the output and describe your observations.

4. Double-click on the Spectrum Analyzer to view its display. Be patient. It may take several seconds to view the spectral lines of interest. Find the carrier frequency of 2 kHz by dragging the red marker and observing the frequency to the lower right of the spectral diagram.
5. Find the sideband frequencies listed below using the red marker and record their values.

$f_c - 3 f_m =$	$f_c - 2f_m =$	$f_c - f_m =$
$f_c + f_m =$	$f_c + 2f_m =$	$f_c + 3f_m =$
6. Stop the simulation. Double-click the FM Source and change the modulation index to 1.5.
7. Run the simulation and comment on what you observe.

Section 11: Waveguides and the Network Analyzer

Section Contents

This section contains the following:

- “Introducing Waveguides and the Network Analyzer” on page 11-2.

Worksheets in this Section

The worksheets in this section start on page 1 of Worksheet 11-1:

- “Worksheet 11-1: Waveguides”
- “Worksheet 11-2: Impedance Matching”.

Circuits for this Section

The following is a list of the file names of circuits used in this section and a brief description of each.

File (.ms10)	Description
ImpedanceMatching	A file which, with the help of the Description Box, demonstrates the impedance matching abilities of Multisim’s Network Analyzer.
Waveguide	A file containing a waveguide which uses Multisim’s Network Analyzer for its investigation.

Introducing Waveguides and the Network Analyzer

This section uses the waveguide circuit **Waveguide.ms10**. Double-clicking on the model then changing its SPICE parameters is required to change the Waveguide module parameters. Students may be introduced to the Network Analyzer through the two files from this section.

The Network Analyzer is used by RF engineers when designing RF amplifiers using Multisim. It can be used to measure scattering parameters of a circuit, which characterize circuits that operate at high frequencies, stability circles for oscillators and unilateral gain circles. The Network Analyzer will calculate H, Y and Z parameters as well as provide impedance matching capabilities. The impedance matching feature is used to match the stable portions of an unconditionally stable circuit. The circuit file **ImpedanceMatching.ms10** uses the Network Analyzer for its impedance matching characteristics.

Worksheets for both of the files are provided.

Goal

To introduce the student to waveguides, impedance matching and the Network Analyzer.

Prerequisites

It is assumed that the student has had an introductory lecture on waveguides, Smith charts and impedance matching before attempting this section.

Observations

- Waveguide SPICE parameters are accessible by double-clicking the waveguide then selecting Edit Model.
- The file **Waveguide.ms10** contains an L-band waveguide.
- It is suggested that the Network Analyzer settings be changed in order to note its many features.

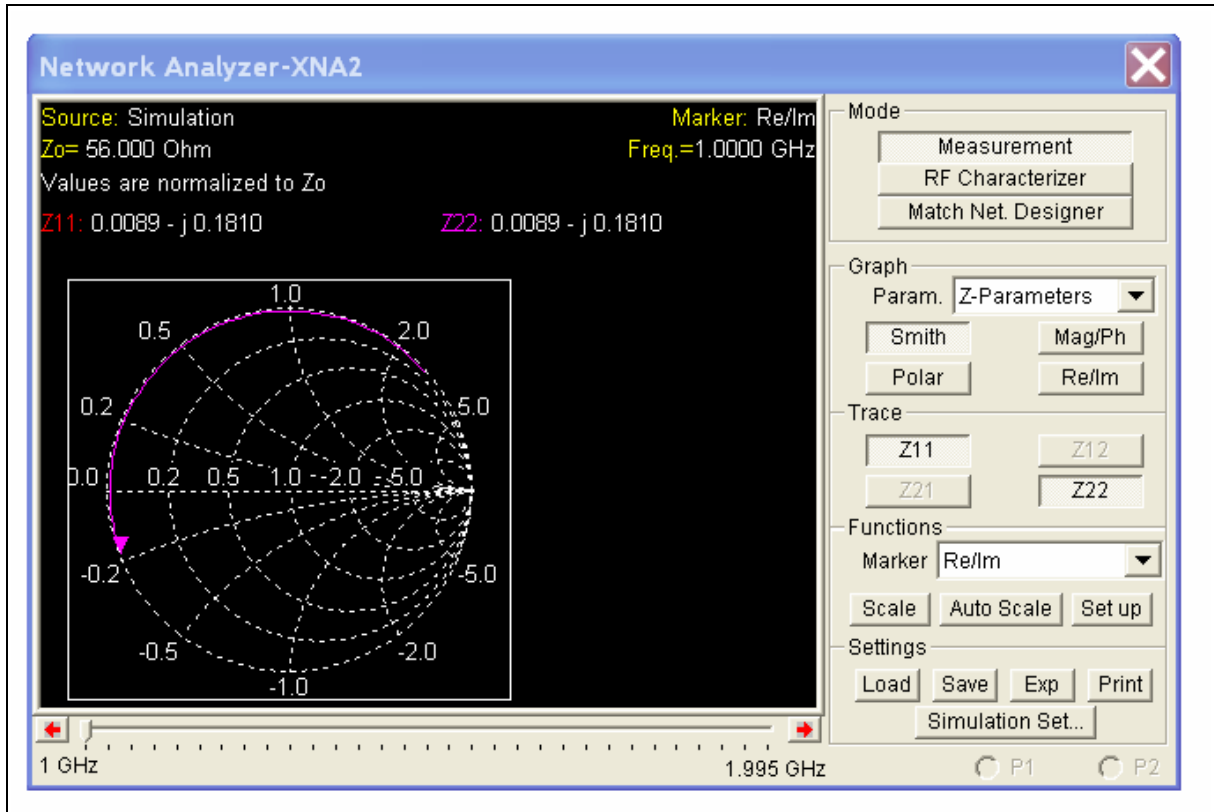

Figure 11-1: Network Analyzer Window

Relevant Worksheets

- “Worksheet 11-1: Waveguides”
- “Worksheet 11-2: Impedance Matching”.

Worksheet 11-1: Waveguides

Name: _____ ID Number: _____ Class: _____

Starting Point

Open the file **Waveguide.ms10**.

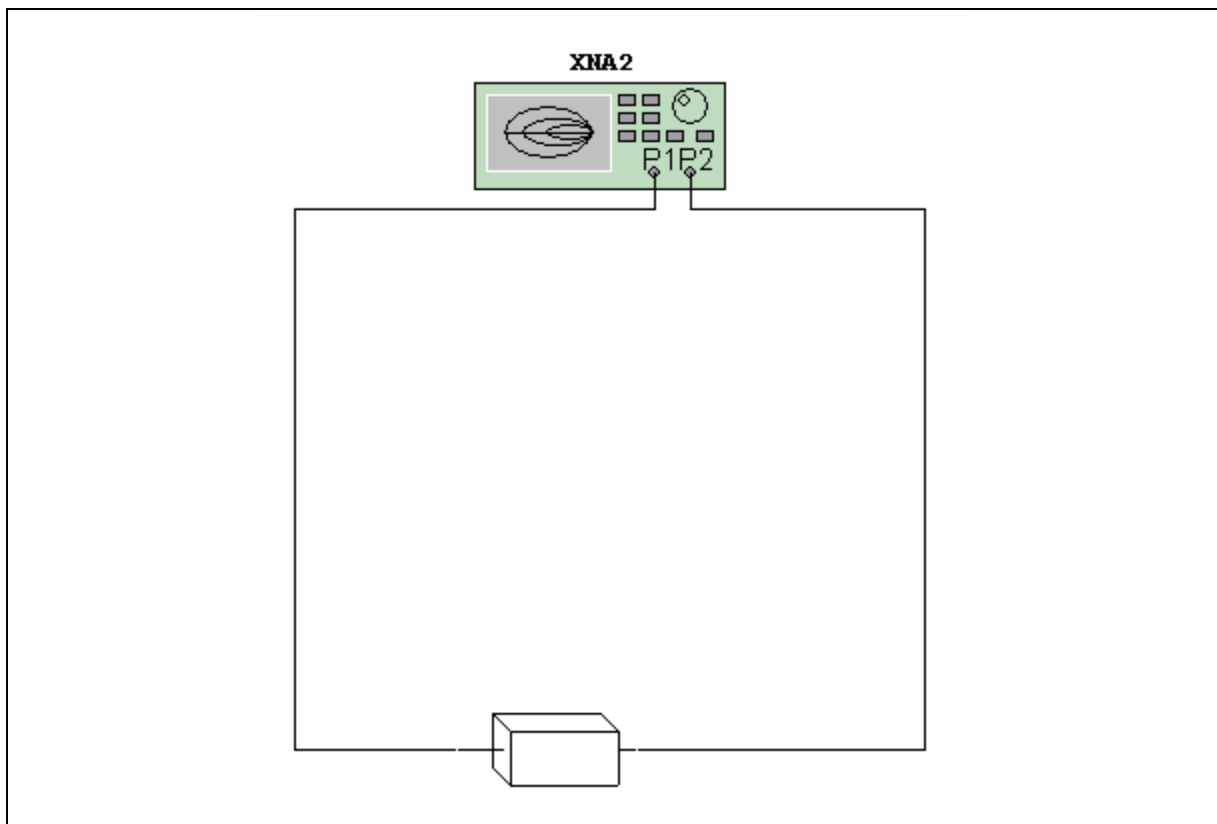

Notes

It is suggested that the Network Analyzer settings be changed in order to note the many features it exhibits.

Questions

1. Double-click on the Network Analyzer to view its display.
2. Run the simulation. Note that the z parameters are along the unit circle denoting $R = 0$.
3. Record the values for Z_{11} and Z_{22} .

$Z_{11} =$

$Z_{22} =$

Worksheet 11-2: Impedance Matching

Name: _____ ID Number: _____ Class: _____

Starting Point

Open the file **ImpedanceMatching.ms10**.

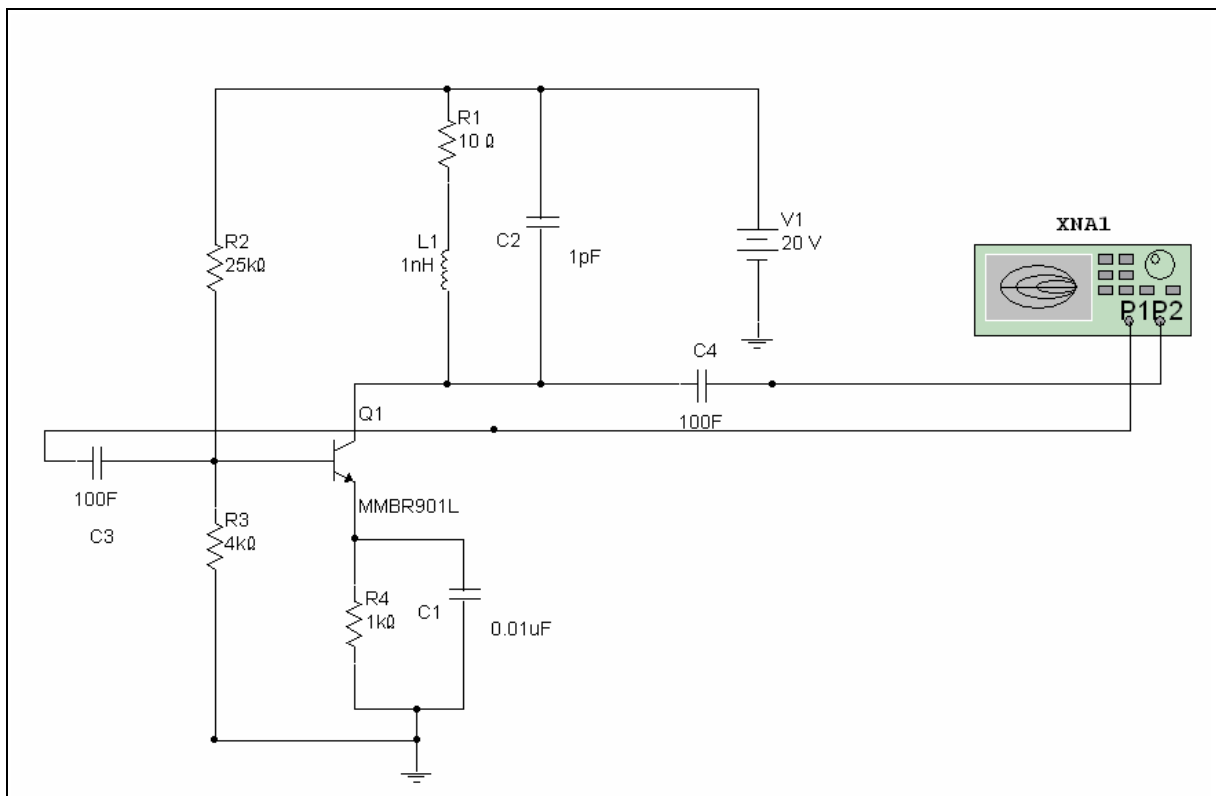

Questions

1. Double-click the Network Analyzer to view its display.
2. Start the simulation.
3. Select **Stability factor** from the **Parameter** drop-down list. Use the scroll bar to change the frequency to 5.2481 GHz.

4. Record the values of delta and K at this frequency.

Delta =

K =

5. Verify that the amplifier is “unconditionally stable” at this frequency.
6. Select **Match Net Designer** from the drop-down list in the **Mode** area. Change the frequency to 5.2482 GHz as a desired operating point. The Match Net Designer dialog appears.
7. Select the **Impedance Matching** tab and enable the **Auto Match** feature. The design components and their values display. Draw the structure.

Section 12: Student Evaluation and Pre-Labs

Section Contents

This section contains the following:

- “Improving Evaluation Techniques” on page 12-3
- “Simulation Lab Tests” on page 12-4
- “Pre-laboratory Assignments” on page 12-5.

Test Questions and Worksheets in this Section

The test questions and worksheets in this section start on page 1 of Test Question 1:

- “Test Question 1”
- “Test Question 2”
- “Test Question 3”
- “Test Question 4”
- “Worksheet 12-1: Pre-Lab1”
- “Worksheet 12-2: Pre-Lab2”
- “Worksheet 12-3: Pre-Lab3”
- “Worksheet 12-4: Pre-Lab4”
- “Worksheet 12-5: Pre-Lab5”.

Circuits for this Section

The following is a list of the file names of circuits used in this section and a brief description of each.

File (.ms10)	Description
Board	A simulation of a prototyping board to familiarize students with the internal connections of such boards.
Test13	A faulted Clipper.
Test1 and Test2	Sample test or quiz questions about op-amps.
Test11 and Test12	FET circuits that are faulted
Test14	A faulted Clamper.
Test15 and Test16	Two Zener circuits which are faulted.
Test17 and Test20	Faulted tests that use the Spectrum Analyzer.
Test18 and Test19	Bridge rectifiers which are faulted.
Test22	A faulted Band Pass filter.
Test3 and Test21	Two tests designed that require a student to set the Spectrum Analyzer to view a specified spectral component.
Test4	A faulted series circuit.
Test5 – Test7	Common Collector circuits that are faulted.
Test8 – Test10	Common Emitter circuits that are faulted.
Pre-Lab1-Pre-Lab5	Pre-lab exercises to be completed before entering the lab.

Improving Evaluation Techniques

Multisim defies the evaluation limitations that have been the norm for many years. It allows for exciting student evaluation methodologies that can be used with success.

The evaluation techniques discussed in this section:

- Save marking time
- Highlight distinctions between numerical and conceptual student errors
- Can be quickly and easily customized for individual students to prevent copying
- Can be printed for handouts or copied to disks to be handed in
- Allow students who have worked in groups and have done the majority of work themselves to take credit for their accomplishments

With Multisim, you have the option to hand out printed copies of the instruments that have been available to the student and any schematics that you wish to present in Multisim format. Students can be asked to answer multiple choice questions pertaining to the handouts. Students can also be asked to draw the expected output from specific circuits. They can also be challenged to sketch the contents of a given black box.

One very good method of evaluation is through the use of the Description Box contained in any given circuit. The student can answer the questions in the Description Box and hand his/her results in on disk.

To use the Description Box

1. Open the circuit file. Select **Tools/Description Box Editor**.
2. Begin typing your test or exam. You can enter as much text as you wish.

Note: The contents of the Description Box may be printed for use with other means of evaluation. Both the circuit and the Description Box may be printed to a hardcopy for examination purposes. Select **File/Print** to print the schematic. To print one or more instruments independently, select **File/Print Options/Print Instruments**. In order to print a circuit with no results showing, run the file then quickly stop the run. All values will be set to zero. You can also use the **Simulate/Clear Instrument Data** command to remove data from all instruments and the Grapher.

Simulation Lab Tests

Goal

To provide a test situation which is meaningful to the student, requiring both theoretical calculations and demonstration of ability to use appropriate test equipment to solve a circuit.

Comments on Test1

Test question 1 includes a circuit that the student is asked to solve as in a regular written test, before simulation. After simulation, the student is asked to measure the parameters that were previously solved on paper.

The written portion of the test might be handed in before the student is permitted to run the simulation.

Comments on Test2

Test question 2 requires a good knowledge of test equipment as well as measurement techniques. Students are required to determine circuit performance by measurements of components when the values are hidden.

Comments on Test3

Multiple tests and exams are easy to set up and mark when Multisim is used for the evaluation. The use of Multisim can make multiple tests simple to implement. Circuit files such as **Test3.ms10** may be quickly reproduced and printed with altered test questions, simply by double-clicking on component values to change them. The files may then be presented in hard or soft copy for student evaluation.

Test question 3 is an example of how you can mark test and exam questions without the use of a complete solution set. Indicators may be placed into a circuit file, to provide you with quick solutions for all questions. Only one solution file needs to be created. For multiple tests involving different values of components, the values of your solution file components can easily be changed with instantaneous results.

Students who have made simple errors in test questions, such as using a different value than requested, have often lost more marks than perhaps was necessary for a fair evaluation. Using Multisim, this problem is easily addressed by simply changing the value to that which the student used and checking his/her results with the simulation.

Relevant Test Questions

- “Test Question 1”
- “Test Question 2”
- “Test Question 3”
- “Test Question 4”.

Pre-laboratory Assignments

Goal

- To enhance use of the limited practical laboratory facilities in your school system
- To reduce the cost of replacement parts/test equipment.

Prerequisites

You will need circuit files **Board.ms10** and **Pre-Lab.ms10**, **Clipper.ms10**, **Clamper.ms10**, **Transistor.ms10** and **Template.ms10**.

Comments

Replacing the initial student laboratory experience with a Multisim environment may significantly reduce instrument and component replacement costs. However, a simulated environment cannot replace traditional laboratories. Students will be expected to be able to use the real thing in industry.

Students can become proficient in the use of instruments and components before being introduced to the physical equipment. More efficient laboratory time will result. Less breakage, allowing greater percentages of budgets to be placed back into the classroom can result.

Suggested Procedure

Part One: Simulating Circuit Behavior

Students might be expected to draw the expected Oscilloscope trace on the supplied worksheet. The instructor would initial this worksheet as correctly completed before the student would run the simulation and proceed to Part Two of this pre-lab assignment. You can create a series of unique files for different lab groups.

Part Two: Simulating Breadboard Construction

In the second part of this pre-lab activity, you can have students build and simulate the circuit on a virtual breadboard. This exercise can resemble as closely as possible the situation that will face them in the practical lab.

Extension Ideas

Proficient use of the Multisim software program itself may be used as a pre-laboratory assignment. As well, Multisim's breadboarding feature can be incorporated with any of the labs which are included with this workbook. Students should be able to demonstrate the proper use of test equipment before they are permitted access to the real instrument. They can first simulate circuits that they plan to build. Apply this strategy wherever it seems applicable.

Relevant Worksheets

- “Worksheet 12-1: Pre-Lab1”
- “Worksheet 12-2: Pre-Lab2”
- “Worksheet 12-3: Pre-Lab3”
- “Worksheet 12-4: Pre-Lab4”
- “Worksheet 12-5: Pre-Lab5”

Test Question 1

Name: _____ ID Number: _____ Class: _____

Starting Point

Open circuit file **Test1.ms10**.

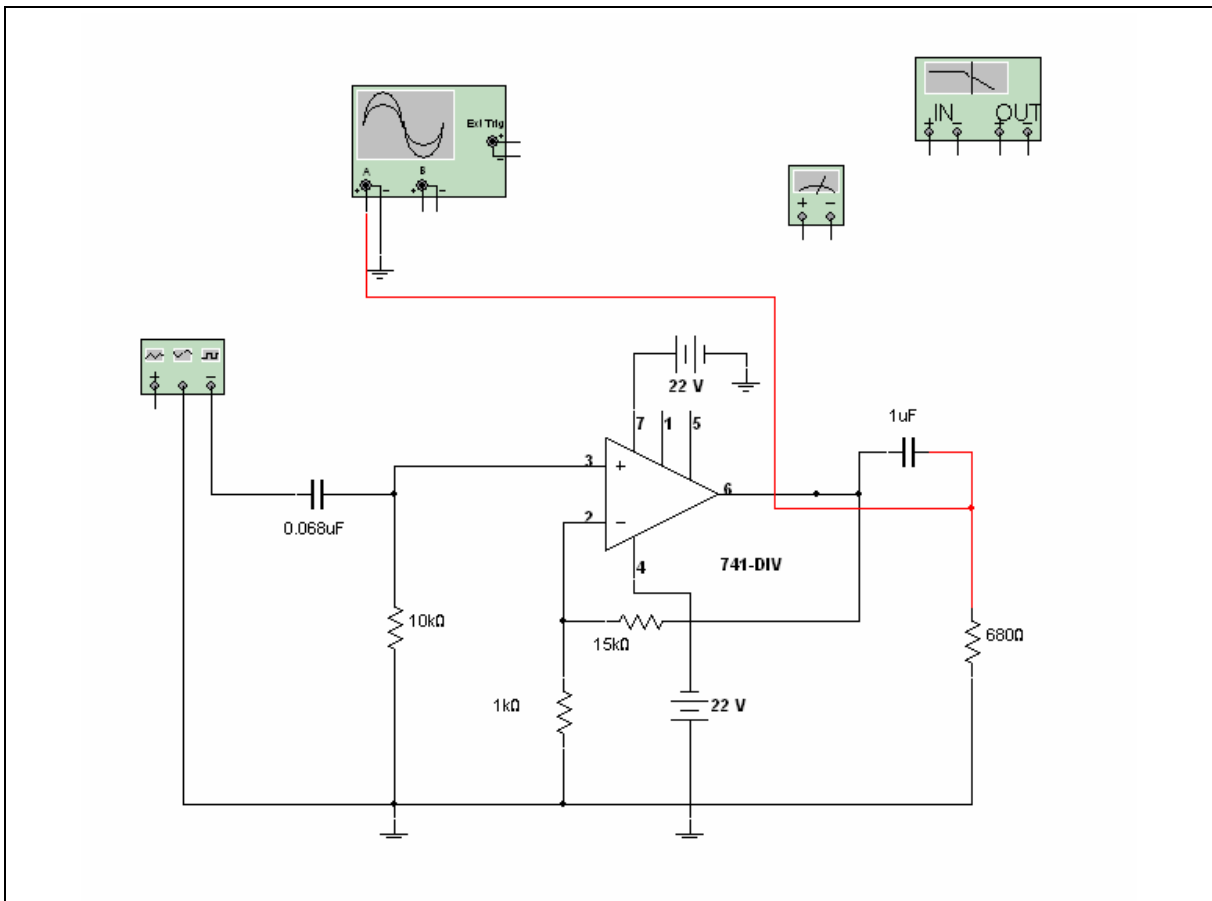

Questions

1. Use basic op-amp theory to calculate the voltage gain, upper and lower -3dB frequencies, and maximum possible undistorted output voltage for the circuit shown. (You can get op-amp characteristics from the op-amp model library.)
2. Record all answers and show calculations.

3. Simulate circuit **Test1.ms10** and measure circuit performance (as calculated in question 2). To measure -3dB frequencies, use the Signal Generator, the Oscilloscope (or Multimeter) and the Bode Plotter.
4. Your solution from Multisim must be handed in as a file. Include all instrument settings as used.

Test Question 2

Name: _____ ID Number: _____ Class: _____

Starting Point

Open file **Test2.ms10**.

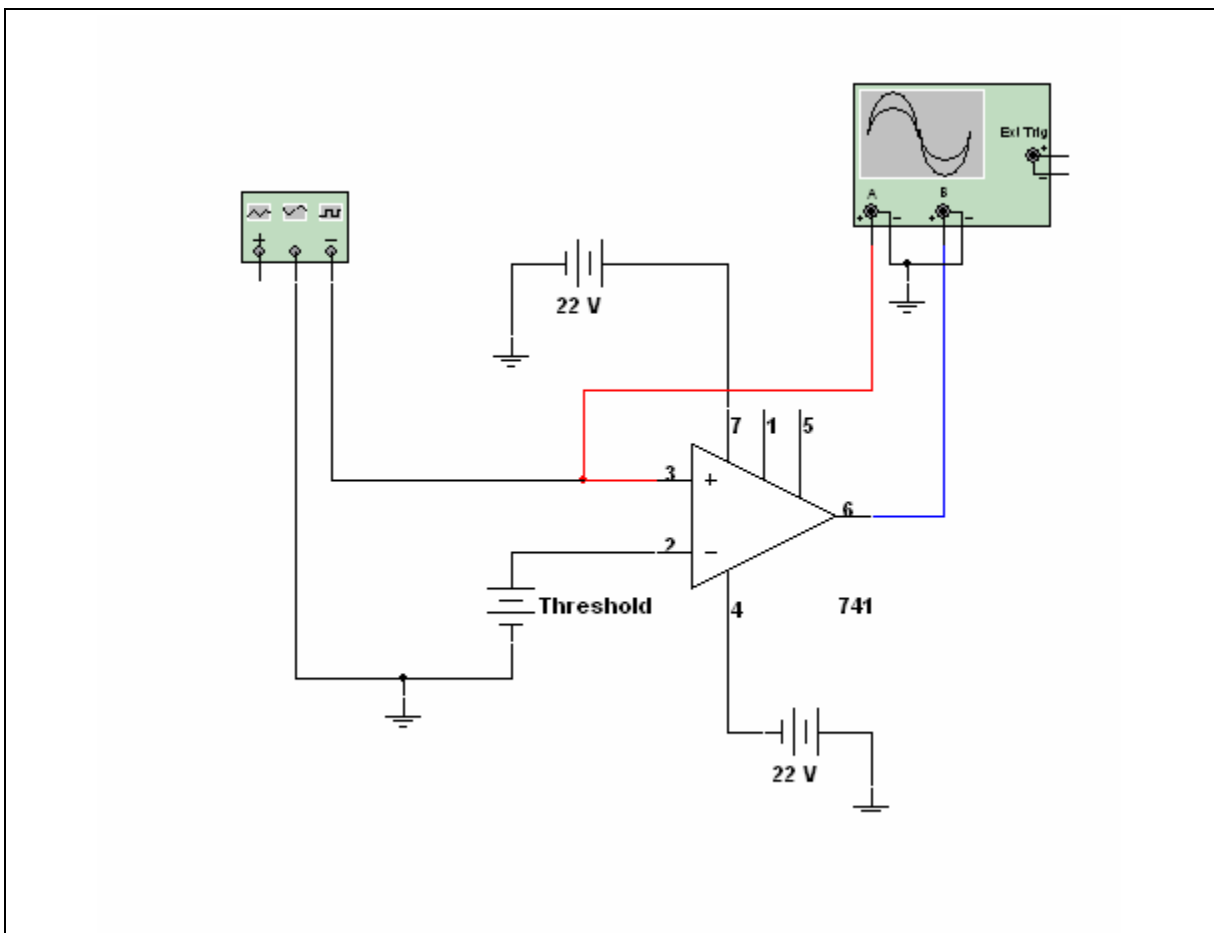

Procedure

1. Solve the circuit and make any test equipment settings necessary to find the value of the threshold voltage.
2. Have the instructor check your solution on-screen.
3. Save your solution on a disk, including the test equipment used with the solution shown, and hand it in to the instructor. Fill in answers for Problems 1 and 2 below.

Problems

1. Identify the type of circuit.

2. Find the value of the threshold voltage.

V (threshold) =

Test Question 3

Name: _____ ID Number: _____ Class: _____

Starting Point

Open Test3.ms10.

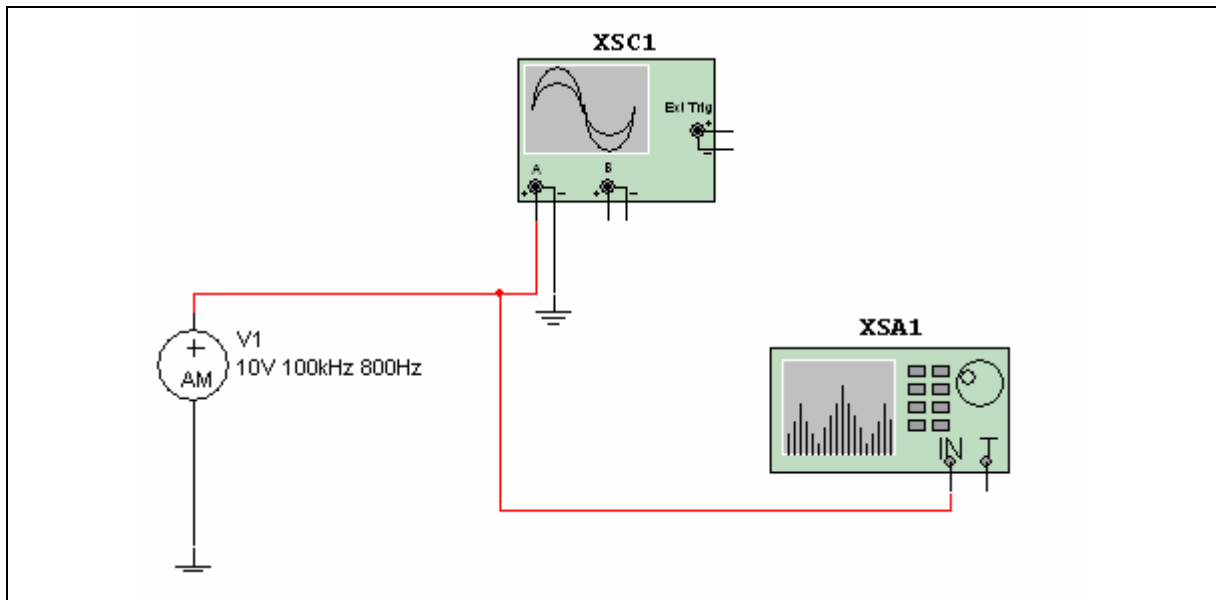

Procedure

1. Adjust the Spectrum Analyzer to display the output.
2. Demonstrate the results to your instructor.

Test Question 4

Name: _____ ID Number: _____ Class: _____

Starting Point

Open Test4.ms10.

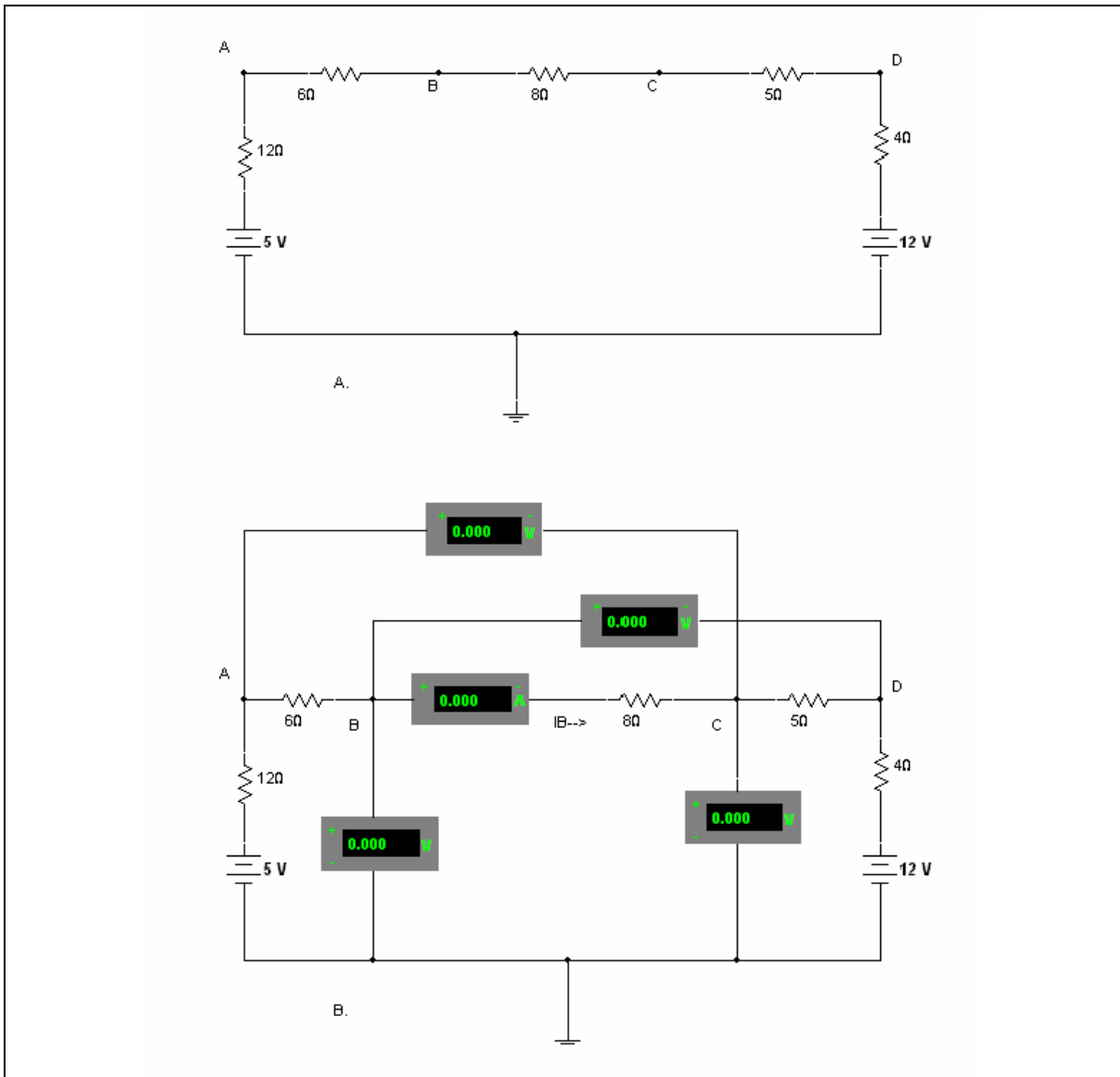

Suggested Procedure

Part A might represent a test given to a student. The Description Box could be used to ask the student to find I_B , V_{CA} , V_{BD} , V_B and V_C . Simply double-clicking on the components to change their values allows multiple tests to be produced.

Part B is the same circuit as part A. Use basic op-amp theory to calculate the voltage gain, upper and lower 3-dB frequencies, and maximum possible undistorted output voltage for the circuit shown. Simply by changing the component value to that of the particular student and observing the results allows individual tests to be marked.

Worksheet 12-1: Pre-Lab1

Name: _____ ID Number: _____ Class: _____

Starting Point

Observe the diagram below. This can be found in the file **Board.ms10**.

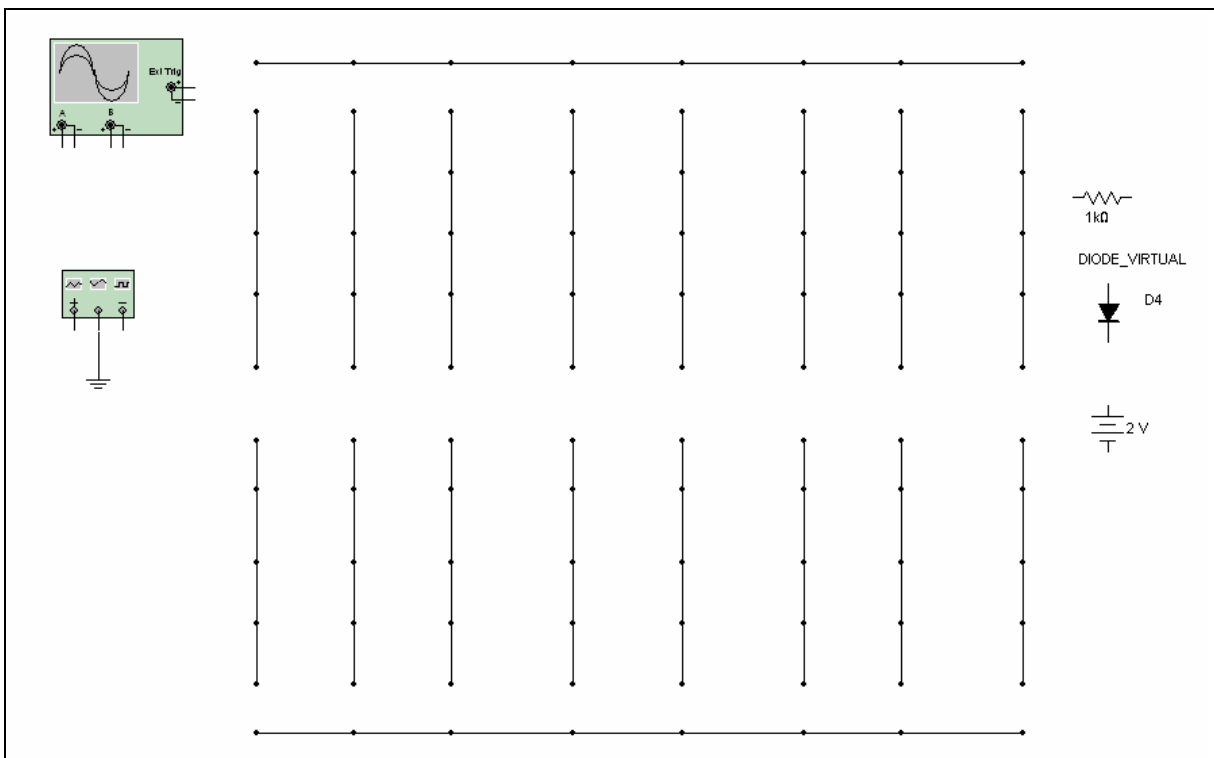

Open circuit file **Pre-Lab.ms10**.

Questions

The use of the protoboard is confusing for some students. The drawing in the main window of **Board.ms10** attempts to show you how the pins are connected inside the board. Use this prototype to breadboard **Pre-Lab.ms10**.

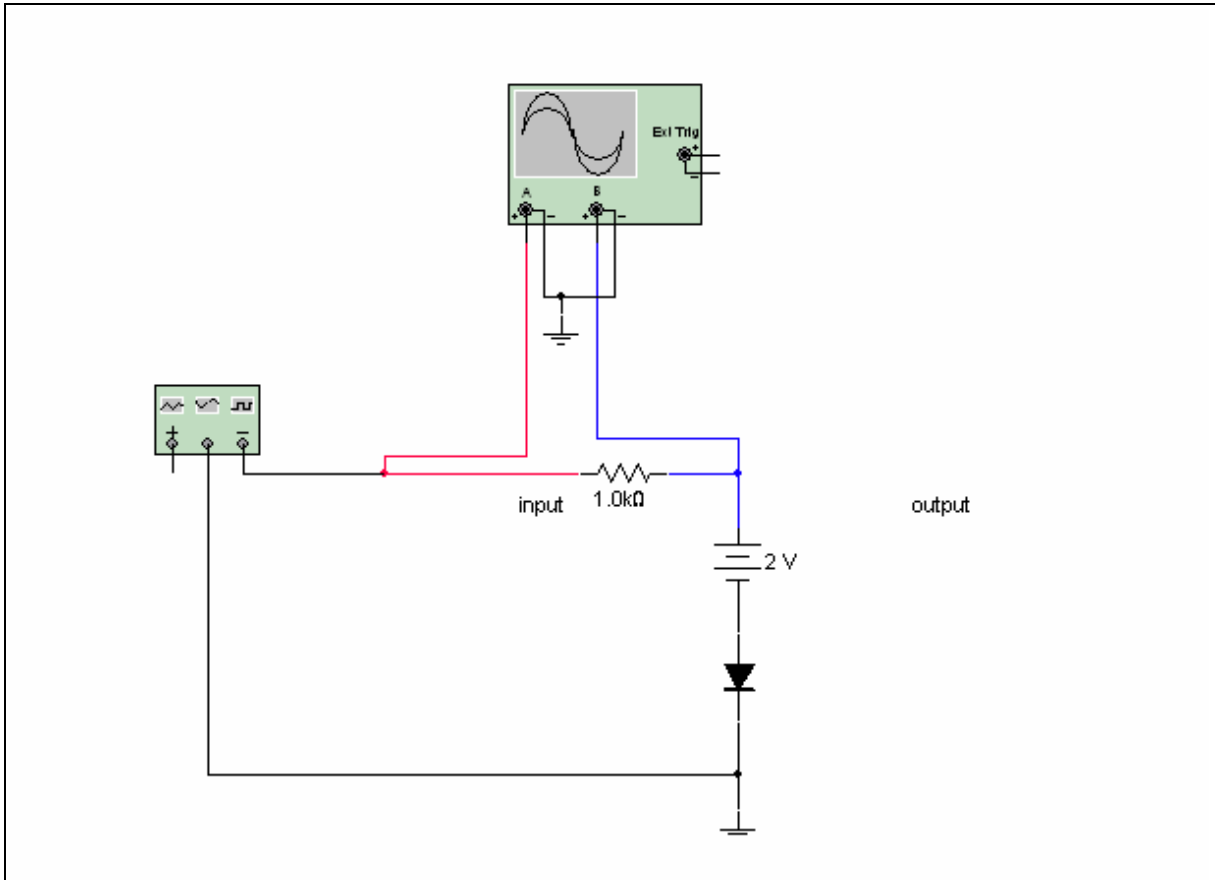

1. Select **Tools/Show Breadboard**. A simulated breadboard environment will be displayed. Click on the arrows to display each component that exists in the schematic. Breadboard **Pre-Lab.ms10** by dragging each component onto the breadboard and creating the connections.
2. Save your circuit and obtain instructor's initial. _____

3. Given a triangle wave input of 1 kHz and 6 V, draw the expected results for the scope as it is connected.

Worksheet 12-2: Pre-Lab2

Name: _____ ID Number: _____ Class: _____

Starting Point

Open **Clipper.ms10**.

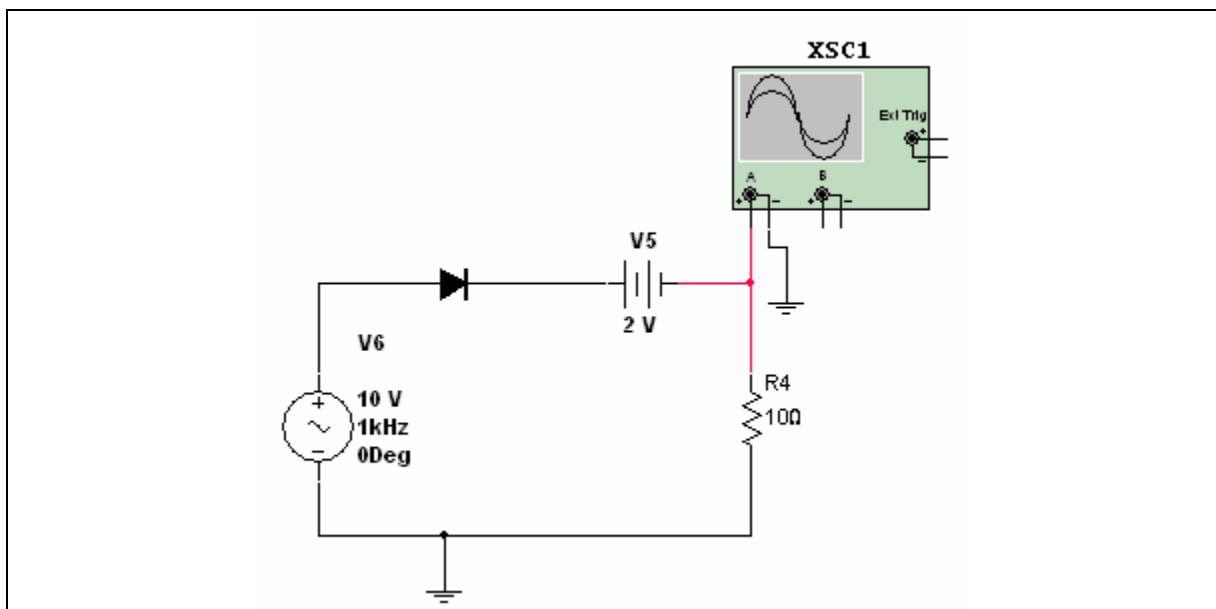

Notes

The use of the protoboard is confusing for some students. The drawing in the main window of **Board.ms10** attempts to show you how the pins are connected inside the board. Use the **Board.ms10** prototype to breadboard **Clipper.ms10**.

1. Select **Tools/Show Breadboard**. A simulated breadboard environment will be displayed.
2. Click on the arrows to display each component that exists in the schematic.
3. Breadboard **Clipper.ms10** by dragging each component onto the breadboard and creating the connections.
4. Save your circuit and obtain instructor's initial. _____
5. Given a sine wave of 10V, 1 kHz, draw the expected output.

Worksheet 12-3: Pre-Lab3

Name: _____ ID Number: _____ Class: _____

Starting Point

Open **Clamper.ms10**.

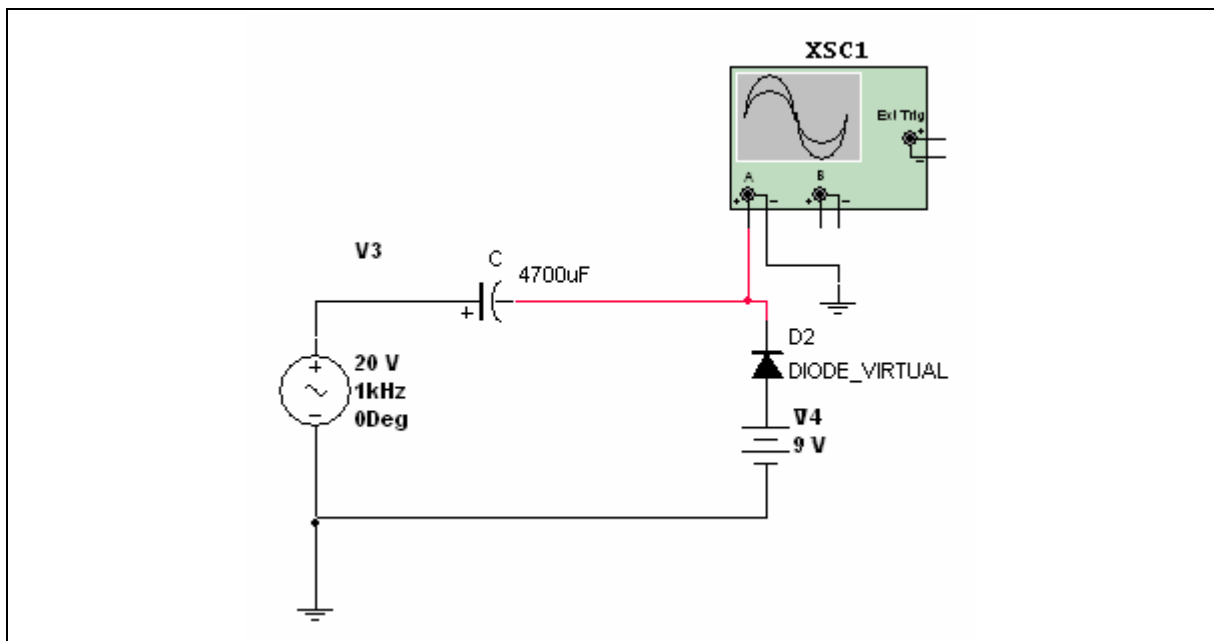

Notes

The use of the protoboard is confusing for some students. The drawing in the main window of **Board.ms10** attempts to show you how the pins are connected inside the board. Use the **Board.ms10** prototype to breadboard **Clamper.ms10**.

1. Select **Tools/Show Breadboard**. A simulated breadboard environment will be displayed.
2. Click on the arrows to display each component that exists in the schematic.
3. Breadboard **Clamper.ms10** by dragging each component onto the breadboard and creating the connections.
4. Save your circuit and obtain instructors initial. _____
5. Given a 20V, 1 kHz signal, draw the expected waveform.

Worksheet 12-4: Pre-Lab4

Name: _____ ID Number: _____ Class: _____

Starting Point

Open **Transistor.ms10**.

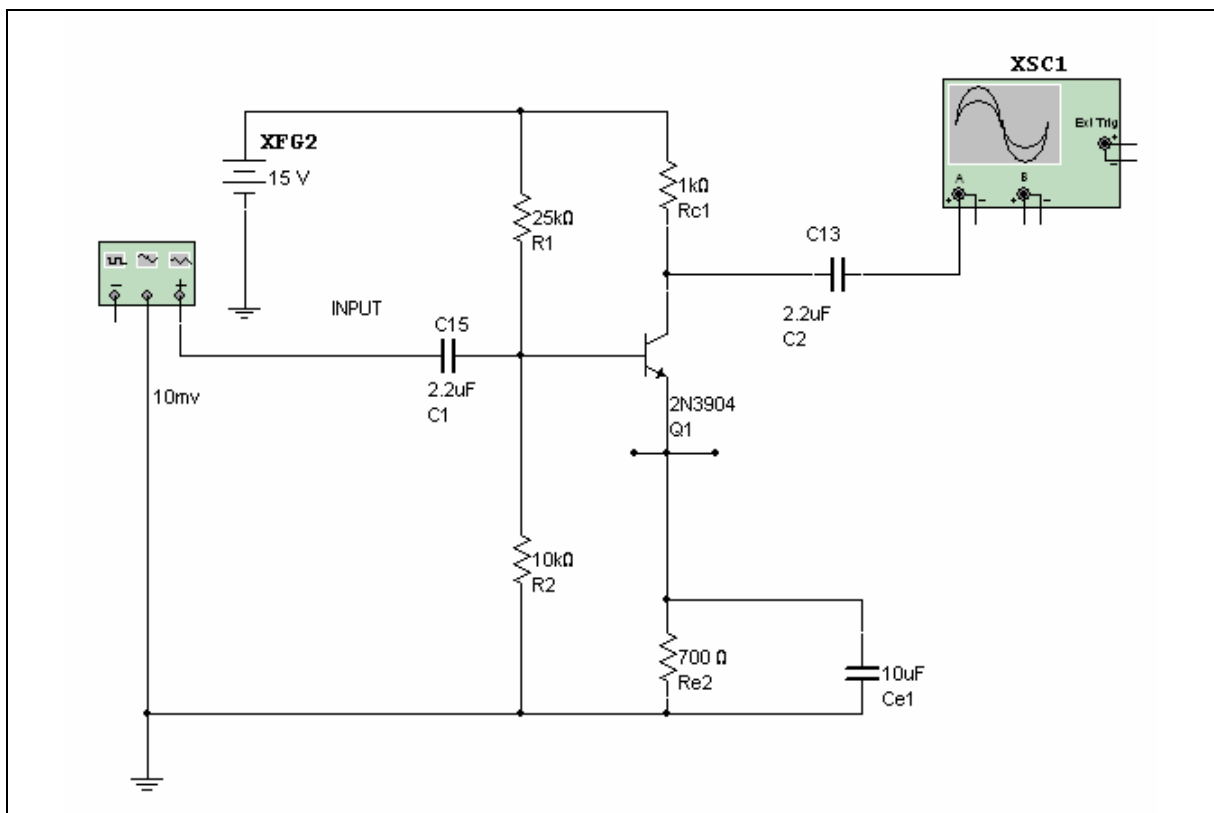

Notes

The use of the protoboard is confusing for some students. The drawing in the main window of **Board.ms10** attempts to show you how the pins are connected inside the board. Use the **Board.ms10** prototype to breadboard **Transistor.ms10**.

1. Select **Tools/Show Breadboard**. A simulated breadboard environment will be displayed.
2. Click on the arrows to display each component that exists in the schematic.
3. Breadboard **Transistor.ms10** by dragging each component onto the breadboard and creating the connections.
4. Save your circuit and obtain instructor's initial. _____
5. Calculate I_B , I_C , and I_E

6. Calculate V_{CE}

7. Calculate the maximum input voltage without clipping.

Worksheet 12-5: Pre-Lab5

Name: _____ ID Number: _____ Class: _____

Starting Point

Open **Template.ms10**.

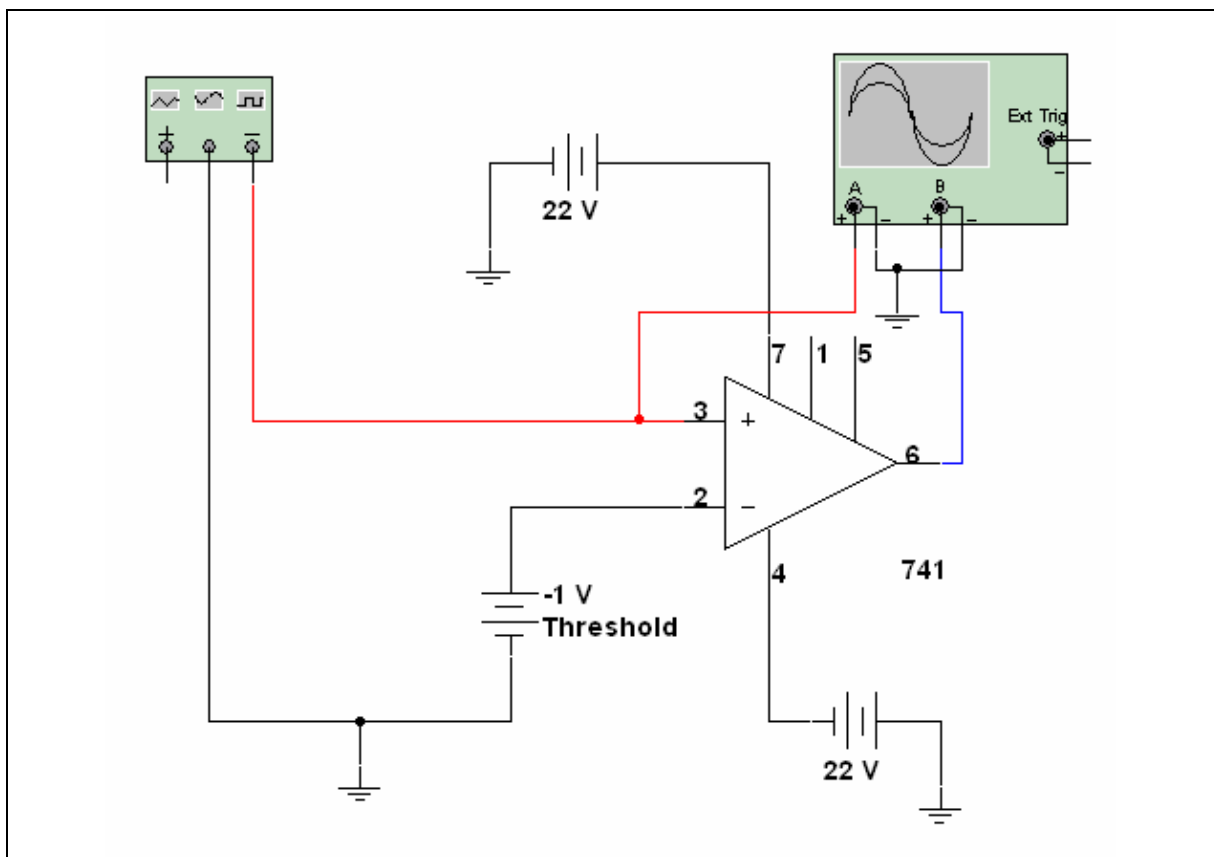

Notes

The use of the protoboard is confusing for some students. The drawing in the main window of **Board.ms10** attempts to show you how the pins are connected inside the board. Use the **Board.ms10** prototype to breadboard **Template.ms10**.

1. Select **Tools/Show Breadboard**. A simulated breadboard environment will be displayed.
2. Click on the arrows to display each component that exists in the schematic.
3. Breadboard **Template.ms10** by dragging each component onto the breadboard and creating the connections.
4. Save your circuit and obtain instructor's initial. _____
5. Solve the circuit, and make any test equipment settings necessary to find the value of the threshold voltage.
6. Have the instructor check your solution on-screen.
7. Save your solution on a disk, including the test equipment used with solution shown, and hand in to the instructor.
8. Be sure to fill in answers for Problems #1 and #2 below.

PROBLEMS

1. Identify the type of circuit.

This circuit is _____ .

2. Value of the threshold voltage.

V(threshold) = _____