



ENGINEERING EDUCATION EQUIPMENT

FROM LEGACY TO INNOVATION.

SINCE 1963

FROM EXPERIENCE.
INTO THE FUTURE.

PRODUCT CATALOGUE

2026

TERCOSWEDEN.COM



CONTENT

Section

	Important Notice - Explanation of Suffix, Guarantee and Terms.....	2,202
1	PST2200 Power System Simulator Laboratory.....	3-28
2	PTG2000 Power Generation, Transmission and Grid Modular System.....	29-46
3	Electrical Machines Laboratory.....	47-70
	Electrical machines 1 kW with characteristics as large.....	48-61
	Reference Pictures.....	62
	Drives.....	63-66
	Power Factor Control.....	67,68
	Wind Mill System.....	69,70
4	Transmission Line, Transformer and Protection Laboratory.....	71-84
	Transmission Lines.....	72-77
	Transformers.....	78-80
	Line Multi Protection Module.....	81,82
	Differential Relay Module.....	83,84
5	High Voltage Modular Training Set.....	85-108
6	Electrical Installation Laboratory.....	109-122
7	Electronics.....	123-134
	Analogue Electronics Basic.....	124-126
	Digital Electronics Basic.....	127-129
	Power Electronics.....	130-134
8	Three Phase and Motor Control System.....	135-152
	Three Phase AC.....	136-141
	Motor Control System.....	142-147
	Drives.....	148-152
9	Process-, Control-, and Servo Systems.....	153-180
	Process Control Technology and Measuring Technique PID.....	154-157
	Servo Systems.....	158-164
	Energy- and Process Control Trainer.....	165-167
	Control Techniques - PLC.....	168-171
	Automatic Sectional Door Model.....	172-174
	Elevator Model.....	175
	Mecha Kit System.....	176-180
10	Automotive Electronics.....	181-188
11	Material Testing Laboratory.....	189-198
12	Power Supplies and Generators.....	199-203
13	Loads.....	203-206
14	Instrument and Measuring Devices.....	207-217
	Measuring and Data Acquisition for PC.....	208-209
	Instrument.....	210-216
15	Accessories.....	217-222
16	Foldable Device Panel FDP2100.....	223
17	Alphabetical Table of Contents, Guarantee and Terms.....	224-230

Important Notice - Explanation of Suffix

Suffixes indicating voltage and/or frequency ensure that equipment corresponds with the various voltages in different countries.

For DC-machines, all having 220 V supply, the suffix indicates different to match synchronous speeds, speeds alternatively 50 or 60 Hz, when DC and AC machines are coupled together.

Examples of codes involved:

Torque Meter DC-Machines:

MV1036-225 DC-machine Torque Meter (analogue), Voltage 220 V 50 Hz

Rated speed: Generator 1500 rpm, Motor 1400 rpm

MV1036-226 DC-Machine Torque Meter (analogue), Voltage 220 V, 60 Hz

Rated speed: Generator 1800 rpm, Motor 1700 rpm

DC machine MV1036-226 is designed for tests on electrical machines with 60 Hz ratings.

The same concerns Torque Meter DC-Machines with double ended shafts, with basic codes MV1026 and Drive Machine MV 1028 as well as test machines DC MV1006, to which one of the suffixes, -225 or -226, is added as necessary.

AC Test Machines

The suffix indicates in this case frequency and supply voltage as follows:

-405 supply voltage Star 400 V, Delta 230 V, Frequency 50 Hz

-406 same supply voltages, Frequency 60 Hz

Examples:

MV1007-405: Induction Motor, slip-ring, Star 400 V, Delta 230 V, 50 Hz and 60 Hz

MV1008-236: Synchronous Machine, Star 230 V, Delta 133 V, 60 Hz

Sometimes, when there is a '5' as last digit in the suffix, e. g. MV 1007-405, the product can be used both for 50 Hz and 60 Hz (see data in the catalogue).

Load Resistor MV1100

Suffix -115 or -235 indicates only supply voltage for the cooling fan. The unit itself can be used as a load for all the voltages occurring in the electrical machine laboratories, within the admitted current limits.

Other Equipment

The same principles apply to all other items in the price list, coded with a basic number with a suffix.

For other technical details, please check the catalogue.

PLEASE NOTE:

Equipment for other supply voltages can be supplied on request

Guarantee & Terms

All overseas deliveries are dispatched in special, made to order wooden crates, extremely sturdy and damage resistant. The guarantee is valid for 24 months from delivery and covers repair or exchange of parts, defective due to faulty design or workmanship at our factory. Detailed conditions of guarantee are specified in our Terms of Guarantee.

Spare parts for 2-5 years of normal operation can be offered on request.

Regular after-sales service is performed by the worldwide network of Terco representatives, along with the advice and support of our engineers.

Commissioning and training is normally offered separately. Special training can be arranged on request either in Sweden or on site.

Terco is ISO 9001 certified

Terco reserves the right to make changes in the design and modifications or improvements of the products at any time without incurring any obligations.

PST2200 Power System Simulator Laboratory



In most parts of our world we have a limited amount of energy. In addition, our energy is not in the places where it is needed most. To make it even more difficult, the energy consumption in our production facilities is very varied over the clock and throughout the year. Nor can we always store the energy we produce.

With PST2000 - a facility with professional relay protection - you have the opportunity to practice situations that we encounter in today's facilities for the production and distribution of electrical energy.

PST2200 POWER STATION AND TRANSMISSION LABORATORY



PST2200 Power System Simulator with Two Generators, Solar and Grid System

PST2291 Solar Power Module

PST2200 General Introduction

The equipment is built upon free standing modules which can be operated separately, and one SCADA System Module.

Each module is equipped with 4 wheels (2 lockable), and separate power input / output, which means that the modules are fully mobile and can work independently if desired.

Linked together they constitute a complete power system and contain everything needed to teach and train students as well as engineers how electrical power systems work - from generation to utilization.

The system can be supplemented at any time with the other modules.

The modular system will make it possible to arrange experiment scenarios covering real situations with a complexity designed and adjusted to the aims and knowledge level of the students. Adaptation to other conditions as well as partial upgrading is done fast and easily.

The Modules hold an advanced measurement system where each three-phase transducer comprises 20 parameters, where also non-symmetrical behaviour as well as $\cos \phi$ are displayed. This extensive environment can also be studied on the TERCO SCADA-System.

Facilities allowing Power Utilities to give new Trainees necessary skills and experience before getting hands on experience in Power Plants, Transmission and Distribution Systems.

Also giving Staff the necessary training in emergency situations under safe conditions. TERCO works in close cooperation with ABB the world leading corporation in power systems, and consequently using their protection relays. As standard we are using ABB IED Relion series of protection relays. IED stands for Intelligent Electronic Device and is state of the art of protection relays. These protection relays are fully compliant with the World Wide Power Industry Standard, IEC61850.

The Power System Simulator PST2200 includes basic modules and additional modules.

Protection Relay

All the Protection Relays (IED) are constituted by the ABB RELION SERIES which are the same as used in modern power installations. Each relay is pre-configured at the TERCO factory to optimise the functionality of each module.

IED stands for Intelligent Electronic Device and is State of the Art of protection relays. It is fully compliant with the World Wide Power Industry Standard IEC 61850



Protection Relay

3-phase Instruments

Strategically placed 3-phase power network parameter analyzers displaying 20 power energy quantities divided into five selectable pages (each page displaying 4-parameters at a time), featuring for instance:

- Average 3-ph voltage/current
- Visualisation of non symmetrical loads
- Both phase-phase and phase-earth voltages
- Independent phase currents
- Average 3-ph active, reactive and apparent power
- Independent phase active, reactive and apparent powers
- Average 3-ph power factor
- Independent phase power factors
- Active, reactive and apparent energy



3-phase Instruments

Bargraphs

Digital bargraphs, each with dual graphs (one for each busbar) comprise the ability to monitor essential parameters for synchronization purposes:

- Voltage - both busbars monitored with LED's and bargraphs (normally 380-420VAC)
- Frequency - both busbars displayed with LED's and bargraphs (normally 45-55Hz)
- Display levels selectable in three different colours for highlighting of significant values

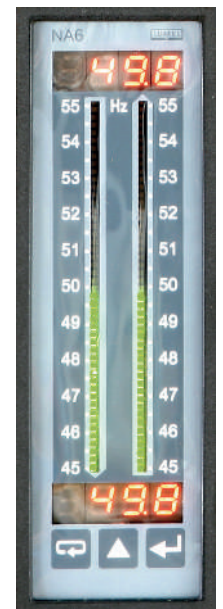

Bargraphs

AC Drive Control Panel



Single Phase Instruments

AC Drive Control Panel

Displaying:

- Frequency command (Hz)
- Output frequency
- Actual motor speed
- Output current
- Start-up time delay selector switches

Single Phase Instruments

- Two instruments for voltages on A- and B-busbars
- Phase-phase and phase-earth by means of selector switch
- Generator magnetizing

Synchronization Instrument

Displaying:

- Phase angle
- Main- and generator voltage delta (dU)
- Earth leakage voltage
- Main- and generator frequency delta (dF)
- Frequency differency
- Phase Sequence Indicator
- Traditional 3-lamp Sequencing Indication



Synchronization Instrument

PST2250-15 SCADA System



PST2252-1 TERCO SCADA System Student Module.

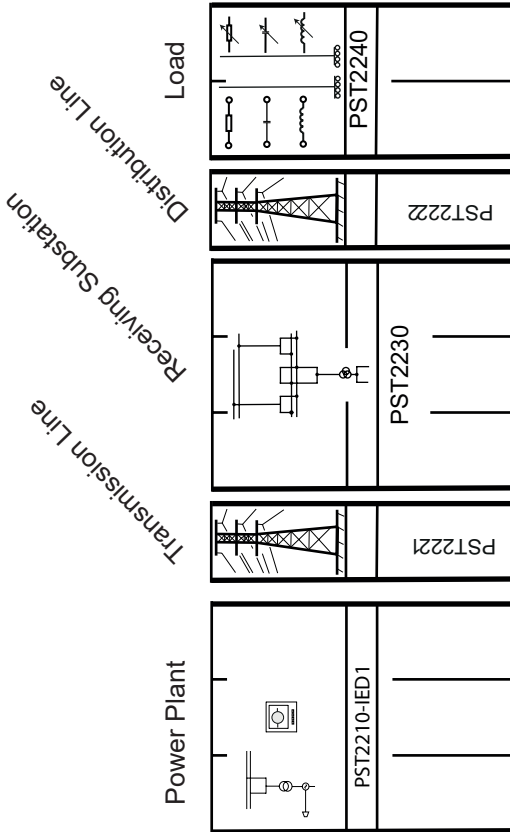

Basic System

The picture above shows a standard Power System Simulator with turbine-generator, power plant section, transmission lines, receiving substation and the load module incl. an induction motor with flywheel.

PST2250-15 SCADA System
Power Factor Controller



PST2252-1 TERCO SCADA System Student Module.

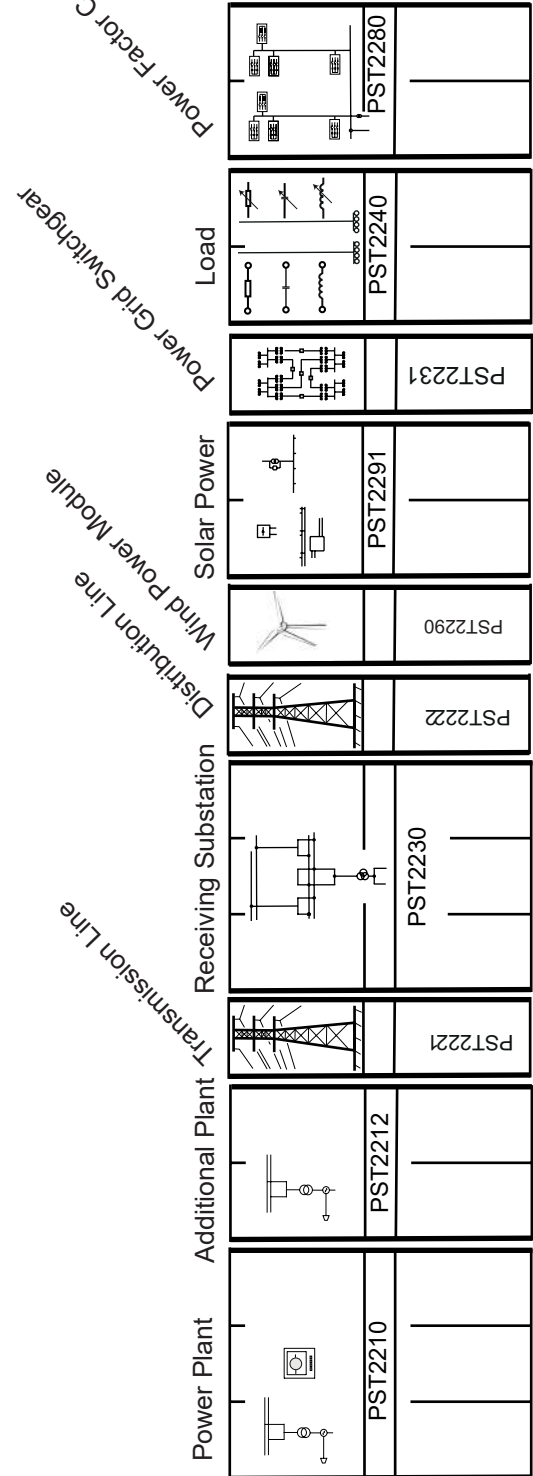

Weights and Dimensions

Each module consists of one, two or three sections. The dimensions and weights can vary slightly with new components.

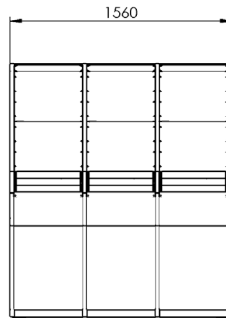
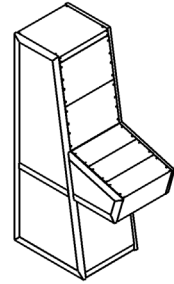
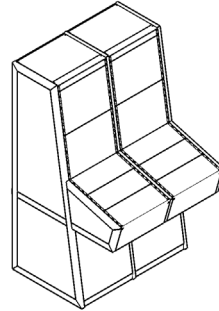
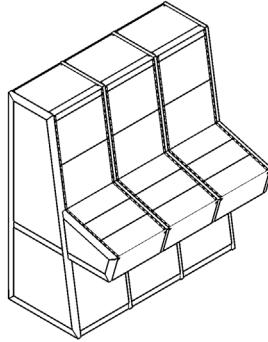
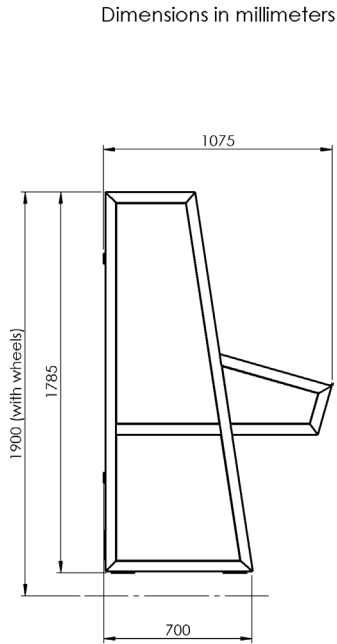

PST2210
PST2230

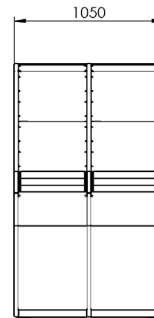

PST2212
PST2291
PST2240
PST2280



PST2221
PST2222
PST2231
PST2290



Each Module is delivered with a PVC-coated polyester fabric.

Power Supply

400V 3-phase, 16A. Each module connects 5 pole (L1, L2, L3, N, Earth) with CEE connection.

The modules Power Supply can be daisy-chained so that only one Power outlet is required

Product no	Description	Weight kg
PST2210	Power Plant Module	360
	(Turbine/Generator)	90
PST2221	Transmission Lines Module.	166
PST2230	Receiving Substation Module	360
PST2222	Distribution Lines Module	132
PST2240	Load Module	242
PST2280	Power Factor Controller	212
PST2212	Additional Power Plant Module	245
	(Turbine/Generator)	90
PST2231	Power Grid Switchgear Module	132
PST2290	Wind Power Module	
	Mast	
PST2291	Solar Power Module	245
	(Photovoltaic Module/unit. Tot. 3 units)	22/unit

PST2210 Power Plant Module



The picture shows PST2210 IED Level 2

General

Power Plant with 2.2 kW 3-phase AC Induction Motor and Field Oriented Programmable Drive for simulating a turbine with different characteristics as:

- Steam turbine (nuclear, geothermal, fossil)
- Hydro-electric turbine
- Small diesel motor

The three-phase 1.2 kVA synchronous generator has electrical parameters similar to real units.

Manual or automatic control both for the frequency (=active power) and the voltage (=reactive power) One-line mimic diagrams together with power breakers and isolators and groups of digital instruments arranged in the same way as in real plants.

The PST2210-module has also synchronization and phasing devices, digital bar-graphs for voltage and frequency, step-up transformer, current and voltage transformers, relay protections, A and B bus bars with two outgoing lines.

Operation of breakers and isolators is controlled and interlocked by PLC's for safe operation by students. The step-up transformers can be operated individually and all terminals are available from the front panel providing access to delta and star-connected windings. Access to the generator windings are provided on the front panel.

Protection relay current transformer windings are accessible on the front panel via external connectors. Possibility for floating, impedance and direct-earthing of transformer and generator is available on front panel.

PST2210 contains a fault simulator with the ability to simulate variable short circuit and earth faults.

The module includes 4, 8-pole Transfer Blocks for easy signal transfer between different compatible modules.

Possible earthing methods:

- a) Solid earth
- b) Resistive earth
- b) Floating earth

....continuation PST2210 Power Plant Module



Technical Specifications

Simulating different types of power plant units:

- Induction Motor 2.2 kW @ 50 Hz, 2.6 kW @ 60 Hz
- Fully programmable AC Drive with HMI for Speed/W control

Step-up Transformer

- Step-up Transformer 230 / 400 V, 2.0 kVA

Generator Data:

- 4-pole Synchronous Generator, 1.2 kVA, cos phi 0.8
- Static PWM rectifier for Voltage / VAR control
- Voltage: 3 x 230 V
- Nominal Current: 3.5 A
- Frequency: 50 Hz / 60 Hz
- Speed: 1500 rpm / 1800 rpm
- Synchronous Reactance 97 %
- Transient Reactance 17 %
- Sub Transient Reactance 8 %

Digital Instruments:

Multiple 3-ph Power Energy Meters displaying 20 values for U, I, P, Q, S, and cos phi is used for:

- Generator
- Step-up Transformer
- Outgoing Lines 1+2
- External Grid

Selectable-line Double-busbar Voltmeters:

- Field Current
- Rpm
- Frequency (Set point, actual)
- Synchroscope for Phase Position, Δ frequency and Δ voltage
- Bargraphs for Voltage and Frequency

Number and type and configuration of the ABB **Intelligent Electronic Devices** (IED) are different depending on the complexity or **Level** that is desired.

Included in all levels:

- IEC61850 GOOSE device information sharing capability
- Easy Parameter Setting Via Web Browser
- Disturbance Recording for in-depth fault analysis

Measurements

Cubicle	WxHxD	1560x1900x1075 mm
Weight		360 kg

Turbine/Generator

Cubicle	WxHxD	300x560x1500 mm
Weight		90 kg

Protection Relays

PST2210 Level 1

IED Transformer + Generator Protection (1 unit - RET630):

- Differential Protection
- Over/Under Voltage Protection
- Frequency Protection (Over/Under/Gradient)
- Negative Sequence Overcurrent Protection
- Neutral Point Earth Fault Protection (Residual Over-Current)
- Neutral Point Earth Fault Protection (Residual Over-Voltage)
- HV / MV Overcurrent Protection

*1 Protection unit in total

PST2210 IED Level 2

IED Transformer + Generator Protection (1 unit - RET630):

- Differential Protection
- Over/Under Voltage Protection
- Frequency Protection (Over/Under/Gradient)
- Negative Sequence Overcurrent Protection
- Neutral Point Earth Fault Protection (Residual Over-Current)
- Neutral Point Earth Fault Protection (Residual Over-Voltage)
- HV / MV Overcurrent Protection

IED Outgoing HV Line 1 & 2 Multi-Protection (2 units – REF615):

- Directional Three-Phase Overcurrent Protection
- Directional Earth Fault Protection
- Three-Phase Overcurrent Protection
- Non-Directional Earth Fault Protection
- Negative Sequence Overcurrent Protection
- Phase Discontinuity Protection
- Negative Sequence Overcurrent Protection
- Auto Reclosing Function

*3 Protection units in total

Power Supply

400V 3-phase, 16A. Each module connects 5 pole (L1, L2, L3, N, Earth) with CEE connection. The modules Power Supply can be dasy-chained so that only one Power outlet is required

....continuation PST2210 Power Plant Module

Protection Relays

**PST2210 Level 3
IED Transformer + Generator Protection
(1 unit - RET630):**

- Differential Protection
- Over/Under Voltage Protection
- Frequency Protection (Over/Under/Gradient)
- Negative Sequence Overcurrent Protection
- Neutral Point Earth Fault Protection (Residual Over-Current)
- Neutral Point Earth Fault Protection (Residual Over-Voltage)
- HV / MV Overcurrent Protection

**IED Dedicated Generator Protection
(1 unit - RET615):**

- Differential Protection
- 95% Stator Earth Fault Protection

**IED Incoming HV Line 1 & 2 Multi-Protection
(2 units - REF630):**

- Distance Protection
- Directional Earth Fault Protection
- Directional Three-Phase Overcurrent Protection
- Non-Directional Three-Phase Overcurrent Protection
- Non-Directional Earth Fault Protection
- Phase Discontinuity Protection
- Negative Sequence Overcurrent Protection
- Reverse Power Protection
- Auto Reclosing Function

*4 Protection units in total

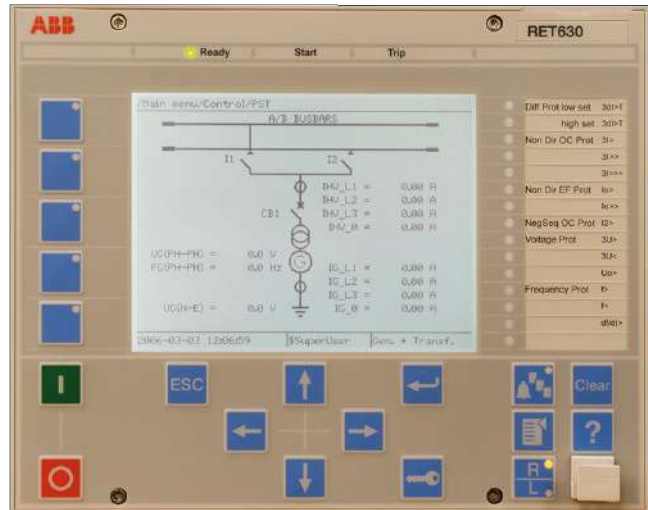

PST2221 Transmission Lines Module

General

PST2221 has 4 scaled down 3-phase OH transmission lines (3 different) with possibilities to change and combine impedance elements to constitute other Overhead Lines (OH) High Voltages (HV) levels.

All models have coils, capacitors and resistors designed to withstand overload and surges for dynamic as well as for static experiments.

All parameters of the transmission models can be changed easily by both internal and external combinations, together with the possibilities of arranging the models in series, parallel or in grid networks.

Each artificial line model consists of a three-phase pi-link and an earth link.

Technical Specifications

One OH- π link	400 kV	700 MVA	400 km	0.04 p.u.
Two OH- π link	230 kV	110 MVA	100 km	0.03 p.u.
One OH- π link	110 kV	80 MVA	75 km	0.08 p.u.

With our Transmission Line Modules, we have a unique combination of HV-lines, Medium-Voltage lines, OH-distribution Voltage lines and Distribution Voltage cables which will enable studies of the typical parameters and characteristics within the four main groups of AC-power transmission and corresponding need of compensation.

It is possible to isolate/separate the different R, L, and C characteristics of each line for individual analysis.

All line models have the same ratings in the model scale: 400 V, 2A.

All line models also have parallel four pole blocks to provide easy facilities of connection.

Measurements

Cubicle	WxHxD	540x1900x1075 mm
Weight		166 kg

Power Supply

400V 3-phase, 16A. Each module connects 5 pole (L1, L2, L3, N, Earth) with CEE connection. The modules Power Supply can be dasy-chained so that only one Power outlet is required



PST2230 Receiving Substation Module

General

Receiving Substation with two HV-incoming lines, HV-busbars arrangement, step-down transformer, two middle voltage bus bars and two outgoing feeders including a complete switch board with instruments and corresponding protection relays. Three or more incoming lines and three or more outgoing lines can be delivered as option as well as extra distribution transformers.

Phases L1, L2, and L3 are accessible on the middle voltage bus bars and feeders via 4 mm safety sockets, enabling to connect PST 2230 directly to a network or to a generator as well as to external loads.

All breakers and isolators are operated by contactor relays via a logical interlocking and tripping system to avoid accidents that may occur due to accidental connections.

PST2230 contains fault simulator with the ability to simulate variable short circuit and earth faults.

The module includes 4, 8-pole Transfer Blocks for easy signal transfer between different compatible modules.

The step down transformer is a 2 kVA Yyn + d transformer with an On-Line Tap Changer (OLTC) for dynamic voltage regulation via 2.5% incremental tapping's from 95% to 105 % on the secondary winding. The step-down transformer also includes a delta winding to help protect the upstream equipment in unbalanced load conditions.

Possible earthing methods:

- a) Solid or resistive earth
- b) Floating earth
- c) Petersen coil (multiple)

The step down transformer can be operated individually and all windings are available via terminals on the front. Current transformers are positioned around the transformer and the connections are available from the front panel.



The picture shows PST2230 IED Level 2

Technical Specifications:

Digital Instruments:

Multiple 3-ph Power Energy Meters displaying 32 values for U, I, P, Q, S, cos phi is used for:

- Dual incoming HV lines
- Step-down Yyn + d transformer
- Dual outgoing MV feeders

Voltmeter instrument for measuring between bus bars on incoming power.

Measurement point selectable by means of a switch.

Number, type and configuration of the **ABB Intelligent Electronic Devices (IED)** are depending on the complexity or Level that is desired.

Terco reserves the right to make changes in the design and modifications or improvements of the products at any time without incurring any obligations



Protection Relays

PST2230 IED Level 1

IED Transformer Protection (1 unit - RET630):

- Differential Protection
- Over/Under Voltage Protection
- Frequency Protection (Over/Under/Gradient)
- Negative Sequence Overcurrent Protection
- Neutral Point Earth Fault Protection (Residual Over-Current)
- Neutral Point Earth Fault Protection (Residual Over-Voltage)
- HV / MV Overcurrent Protection

*1 Protection units in total

PST2230 IED Level 2

IED Transformer Protection (1 unit - RET630):

- Differential Protection
- Over/Under Voltage Protection
- Frequency Protection (Over/Under/Gradient)
- Negative Sequence Overcurrent Protection
- Neutral Point Earth Fault Protection (Residual Over-Current)
- Neutral Point Earth Fault Protection (Residual Over-Voltage)
- HV / MV Overcurrent Protection

IED Incoming HV Line 1 & 2 Multi-Protection (2 units - REF615):

- Directional Three-Phase Overcurrent Protection
- Directional Earth Fault Protection
- Three-Phase Overcurrent Protection
- Non-Directional Earth Fault Protection
- Negative Sequence O/C Protection
- Phase Discontinuity Protection
- Negative Sequence Overcurrent Protection
- Auto Reclosing Function

IED Outgoing Feeder 1 & 2 Multi-Protection (2 units - REF615):

- Three-Phase Overcurrent Protection
- Negative Sequence Overcurrent Protection
- Directional Earth Fault Protection
- Non-Directional Earth Fault Protection
- Phase Discontinuity Protection
- Auto Reclosing Function

*5 Protection units in total

PST2230 IED Level 3

IED Transformer Protection (1 unit - RET630):

- Differential Protection
- Over/Under Voltage Protection
- Frequency Protection (Over/Under/Gradient)
- Negative Sequence Overcurrent Protection
- Neutral Point Earth Fault Protection (Residual Over-Current)
- Neutral Point Earth Fault Protection (Residual Over-Voltage)
- HV / MV Overcurrent Protection

IED Incoming HV Line 1 & 2 Multi-Protection (2 units - REF630):

- Distance Protection
- Directional Earth Fault Protection
- Directional Three-Phase Overcurrent Protection
- Non-Directional Three-Phase Overcurrent Protection
- Non-Directional Earth Fault Protection
- Phase Discontinuity Protection
- Negative Sequence Overcurrent Protection
- Reverse Power Protection
- Auto Reclosing Function

IED Outgoing Feeder 1 & 2 Multi-Protection (2 units - REF615):

- Three-Phase Overcurrent Protection
- Negative Sequence O/C Protection
- Directional Earth Fault Protection
- Non-Directional Earth Fault Protection
- Phase Discontinuity Protection
- Negative Sequence Overcurrent Protection
- Auto Reclosing Function

*5 Protection units in total

Included in all levels:

- IEC61850 GOOSE device information sharing capability
- Easy Parameter Setting Via Web Browser
- Disturbance Recording for in-depth fault analysis

Measurements

Cubicle	WxHxD	1560x1900x1075 mm
Weight		360 kg

Power Supply

400V 3-phase, 16A. Each module connects 5 pole (L1, L2, L3, N, Earth) with CEE connection. The modules Power Supply can be dasy-chained so that only one Power outlet is required

PST2222 Distribution Lines Module

General

PST2222 has 3 scaled down 3-phase Overhead Lines (OH) transmission lines (2 different) and one underground cable link with possibilities to change and combine impedance elements to constitute other OH High Voltages (HV) levels as well as cable models for distribution.

All models have coils, capacitors and resistors designed to withstand overload and surges for dynamic as well as for static experiments.

All parameters of the transmission models can be changed easily by both internal and external combinations, together with the possibilities of arranging the models in series, parallel or in grid networks.

Each artificial line model consists of a three-phase pi-link and an earth link.

With our Distribution Modules, we have a unique combination of HV-lines, Medium-Voltage lines, OH-distribution Voltage lines and Distribution Voltage cables which will enable studies of the typical parameters and characteristics within the four main groups of AC-power transmission and corresponding need of compensation.

Each model can either be studied as a six- or eight pole block or in itself component by component.

It is possible to isolate/separate the different R, L, and C characteristics of each line for individual analysis.

All line models have the same ratings in the model scale: 400 V, 2A.

All line models also have parallel four pole blocks to provide easy facilities of connection.

Power Supply

400V 3-phase, 16A. Each module connects 5 pole (L1, L2, L3, N, Earth) with CEE connection. The modules Power Supply can be dasy-chained so that only one Power outlet is required



Technical Specifications

Two OH- π link	33 kV	20 MVA	20 km	0.05 p.u.
One OH- π link	11 kV	5 MVA	5 km	0.04 p.u.
One Cable- π link	11 kV	5 MVA	5 km	0.04 p.u.

Measurements

Cubicle WxHxD 540x1900x1075 mm
 Weight: 132 kg

PST2240 Load Module

Single Phase Loads

Three Phase Loads

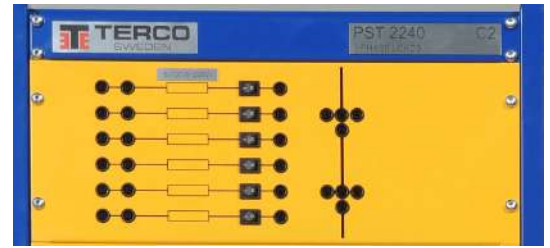

Single Phase Loads



Three Phase Loads



General

Dynamic 3-ph loads with built in simulation of real load trends. A real time of 24h can be simulated down to two minutes.

The Low Voltage Distribution is constituted by bus bars to which the substation can be connected by the outgoing lines or by one or more transmission models.

The Load Module consists of groups of single phase and three-phase industrial and domestic loads.

The loads are of resistive, capacitive, inductive and active (motor) types: Three 3-phase groups can be varied in small steps which together with the other loads will cover load possibilities from 0-150 % of nominal power.

Single-phase distribution groups are available by 4 mm safety outlets to which loads can be connected with or without external instruments.

These single-phase groups enable possibilities to create single-phase loads as well as other non-symmetrical loads.

Power Supply

400V 3-phase, 16A. Each module connects 5 pole (L1, L2, L3, N, Earth) with CEE connection. The modules Power Supply can be dasy-chained so that only one Power outlet is required

Technical Specifications

Digital instruments:

Multiple 3-ph Power Energy meters displaying 20 values for U, I, P, Q, S, and cos phi for use on loads, but connectable at any desired location.

The Loads:

- Six resistive 1-phase load groups connect-able by switches
- Six capacitive 1-phase load groups connect-able by switches
- Six inductive 1-phase load groups connect-able by switches
- One 18 step 3-phase resistive load bank controlled by increase / decrease switch, SCADA or Time-scaled real-life switching schedule
- One 13 step 3-phase capacitive load bank controlled by increase / decrease switch or SCADA
- One 13 step 3-phase inductive load bank controlled by increase / decrease switch or SCADA

Measurements

Cubicle	WxHxD	1050x1900x1075 mm
Weight		242 kg

PST2280 Power Factor Controller



General

With the Power Factor Controller the currents caused by reactive power losses can be minimized, and thereby optimizing the transfer of energy between generation and load.

This is getting more and more important when "saving energy" is vital in a world with focus on pollution and shortage of energy.

Technical Specifications

Number of 3-ph groups:

- 12 capacitive
- 2 inductive

Power Factor Setting:

- 0.7 inductive to 0.7 capacitive
- Nominal voltage - 3x400 V, 50-60 Hz
- Nominal power - 0 - 2 kVAr cap., 0 - 2 kVAr ind.

PF-Controller with touch screen (HMI):

- Automatic or manual modes
- Adjustable delay times, switching sequences and strategies

Monitoring and Measurement on the Controller:

- Power factor (compensated)
- Switching modes - linear, circular
- Panel mounted digital instruments
- Voltmeter (RMS)
- Ammeter (RMS)

Parameter Trend Visualization in graph form on HMI

Digital Instruments:

- Incoming 3-phase current
- Outgoing 3-phase current
- Power Factor Downstream (uncompensated)
- Bank Capacitor branch 3-phase currents

Power Supply:

- 1-ph 220 - 240 V 50-60 Hz (internally supplied)

Measurements

Cubicle	WxHxD	1050x1900x1075 mm
Weight		212 kg

Power Supply

400V 3-phase, 16A. Each module connects 5 pole (L1, L2, L3, N, Earth) with CEE connection. The modules Power Supply can be dasy-chained so that only one Power outlet is required

PST2212 Additional Power Generator



General

Power Plant with 2.2 kW 3-phase AC Induction Motor and Field Oriented Programmable Drive for simulating a turbine with different characteristics as:

- Steam turbine (nuclear, geothermal, fossil)
- Hydro-electric turbine
- Small diesel motor

The three-phase 1.2 kVA synchronous generator has electrical parameters similar to real units.

Manual or automatic control both for the frequency (=active power) and the voltage (=reactive power).

One-line mimic diagrams together with power breakers and isolators and groups of digital instruments arranged in the same way as in real plants.

The PST2212-module has step-up transformer, current and voltage transformers, relay protections for generator and transformer, A and B bus bars.

Operation of breakers and isolators is controlled and interlocked by PLC's for safe operation by students.

The step-up transformers are operated individually and all windings can be available via terminals on the front panel.

All necessary current transformers and voltage transformers are included and the necessary windings accessible via terminals on the front panel.

Possible earthing methods:

- a) Solid earth
- b) Resistive earth
- c) Floating earth

....continuation PST2212 Additional Power Generator

Technical Specifications

Simulating different types of power plant units:

- Induction Motor 2.2 kW @ 50 Hz, 2.6 kW @ 60 Hz
- Fully programmable AC Drive with HMI for Speed/W control

Step-up Transformer:

- Step-up Transformer 230 / 400 V, 2.0 kVA

Generator Data:

- 4-pole Synchronous Generator, 1.2 kVA, cos phi 0.8
- Static PWM rectifier for Voltage / VAr control
- Voltage: 3 x 230 V
- Nominal Current: 3.5 A
- Frequency: 50 Hz / 60 Hz
- Speed: 1500 rpm / 1800 rpm
- Synchronous Reactance 97 %
- Transient Reactance 17 %
- Sub transient Reactance 8 %

Digital Instruments:

Multiple 3-ph Power Energy Meters displaying 32 values for U, I, P, Q, S, and cos phi is used for:

- Generator
- Step-up Transformer
- Field Current
- Rpm
- Frequency (Set point, actual)

Included:

- IEC61850 GOOSE device information sharing capability
- Easy Parameter Setting Via Web Browser
- Disturbance Recording for in-depth fault analysis

Measurements

Cubicle WxHxD 1050x1900x1075 mm
Weight 245 kg

Turbine/Generator
Cubicle WxHxD 300x560x1500 mm
Weight 90 kg

Power Supply

400V 3-phase, 16A. Each module connects 5 pole (L1, L2, L3, N, Earth) with CEE connection. The modules Power Supply can be dasy-chained so that only one Power outlet is required

Protection Relays



PST2212 Level 1 IED Transformer + Generator Protection (1 unit - RET630):

- Differential Protection
- Over/Under Voltage Protection
- Frequency Protection (Over/Under/Gradient)
- Negative Sequence Overcurrent Protection
- Neutral Point Earth Fault Protection (Residual Over-Current)
- Neutral Point Earth Fault Protection (Residual Over-Voltage)
- HV / MV Overcurrent Protection

*1 Protection unit in total



Terco reserves the right to make changes in the design and modifications or improvements of the products at any time without incurring any obligations

PST2231 Power Grid Switchgear Module

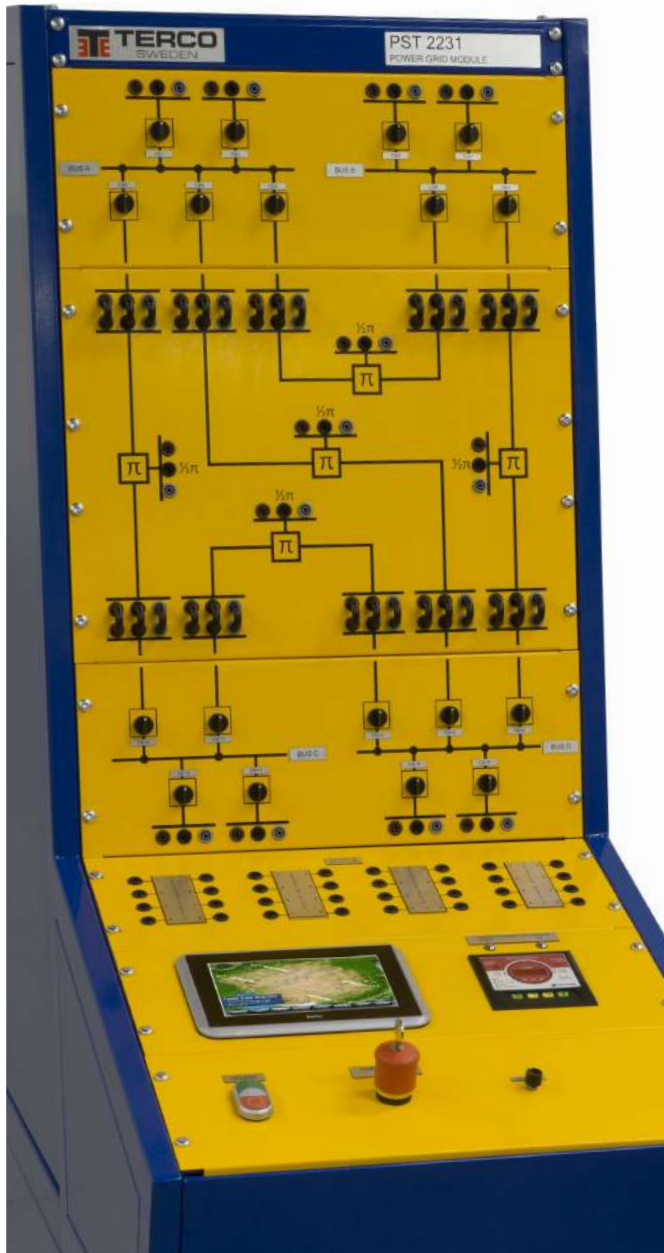

General

PST2231 allows the user to interconnect several power sources and loads to simulate a transmission and distribution grid.

The unit consists of 5 high voltage OH transmission line models connecting 4 different HV buses. Each bus has 2, 3-phase terminals for the connection of various power sources and loads. Full control is obtained by 18 inbuilt circuit breakers and a dynamic synchronization system.

The synchronization system connects multiple power sources into a live system at any of the 18 inbuilt breakers. Synchronization is controlled from the Human Machine Interface (HMI) touch screen operator panel.

Each circuit breaker is fully monitored via advanced 3-phase power network transducers. Each transducer provides more than 20 power network parameters each, to enable complete monitoring of the network status at all points.

The monitored quantities are to be presented on the HMI, showing the power flow at each point in the network simultaneously.

Each Transmission line model is split into 2 sections and is equipped with connection terminals at halfway, to allow faults such as short-circuits and earth faults to be connected at midway in the transmission line.

Technical Specifications

Digital Instruments

- Synchroscope
- Three-phase instruments (V,A,W,VAR)

Busbars

PST2231 has 4 buses where each allows 2 incoming power sources or outgoing loads. Each bus also has 2-3 outgoing feeders which can be used to connect the transmission lines to other buses in PST2231. Each incoming or outgoing feeder is controlled via a local circuit breaker.

Power Lines

PST2231 has 5 transmission lines consisting of two π link models in series with front panel and access to the midpoint of each line for fault simulations on the line.

HMI

The touch screen HMI provides the user with measurements of over 20 power network parameters at each of the 18 switchgear cubicles. These parameters, when viewed together, provide an overview of the power flow at all points in the network simultaneously.

Features

- Enables interconnection of several PST2200 systems or parts thereof (e.g. PST2210)
- Synchronization with line selector switch
- Simulation of a large power grid
- Possibility to create a redundant power grid and study the operation of faulty transmission lines
- 4 transfer blocks for interconnection with other PST2200 modules

Measurements

Cubicle	WxHxD	540x1900x1075 mm
Weight		132 kg

Power Supply

400V 3-phase, 16A. Each module connects 5 pole (L1, L2, L3, N, Earth) with CEE connection. The modules Power Supply can be dasy-chained so that only one Power outlet is required

...continuation PST2231 Power Grid Switchgear Module

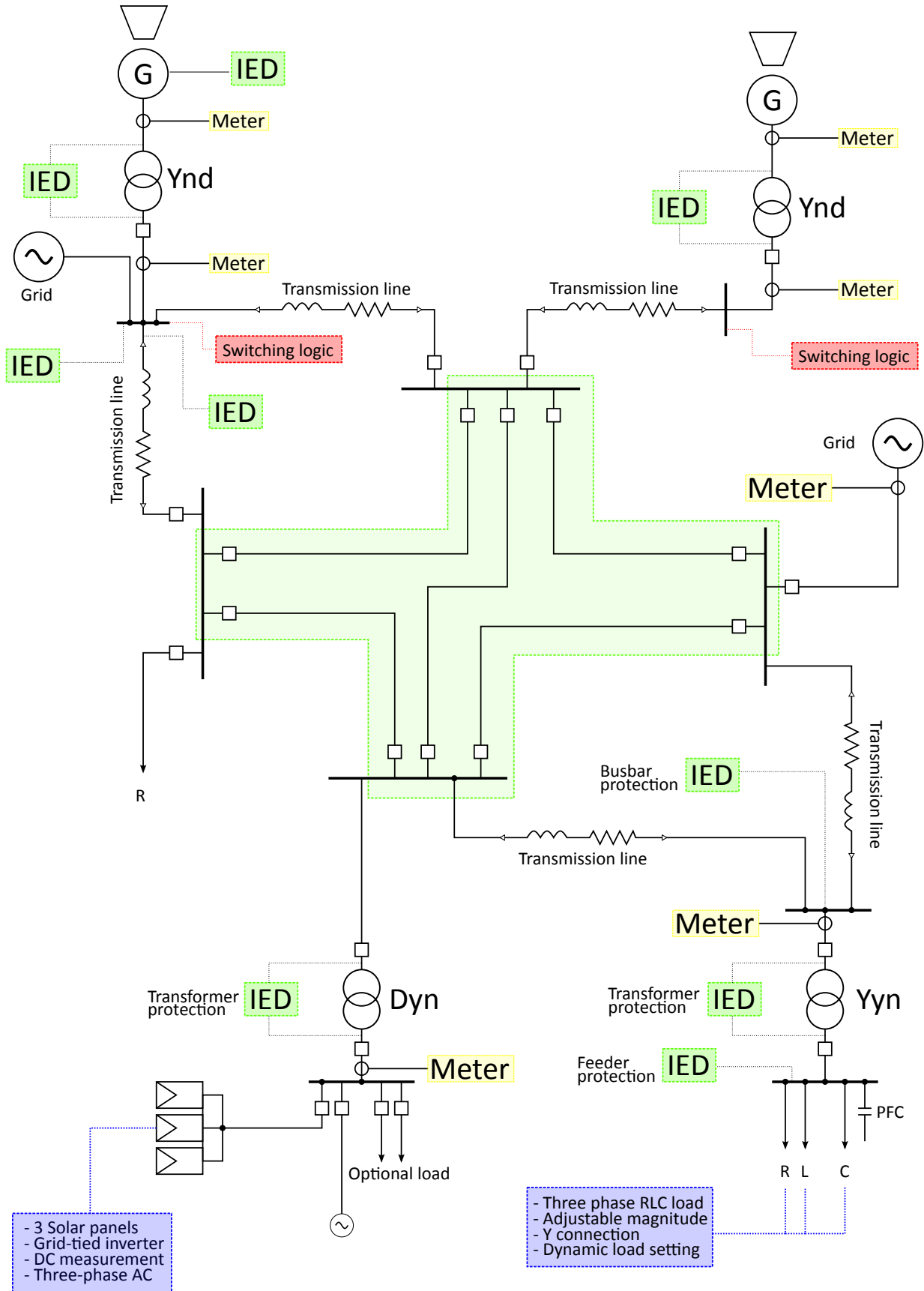

The sketch shows how multiple power systems can be linked together using PST2231

PST2291 Solar Power Module



Power Supply

400V 3-phase, 16A. Each module connects 5 pole (L1, L2, L3, N, Earth) with CEE connection. The modules Power Supply can be daisy-chained so that only one Power outlet is required



General

PST2291 is a free standing module with the same form factor as the other modules. PST2291 is a generator station where the generator consists of three solar panels delivering three-phase power to the module that can further be tied to a grid.

The grid may be a complete PST2200 system or simply the public three-phase grid. PST2291 can be linked together with existing PST2200 modules to form a larger and complete power system with the addition of solar power.

The module simulates a solar farm, containing all necessary equipment such as solar panels, inverters, switchgear, protection modules and voltage transformation before interfacing the grid.

A Solar Farm provides a variety of switching equipment that handles control and switching of both AC and DC.

Circuit Breakers (CBs) can be controlled both from the front panel by means of a switch or remotely from SCADA. The isolators can for safety reasons only be manoeuvred locally.

TERCO Blocking System

There is a built-in switching hierarchy in the PST2291 which prohibits the user from wrong closing operation sequence between Isolators and Circuit Breakers (CB).

Technical Specifications

Electrical Data

Rear side I/O: 3 phase + N + PE 400V/50Hz protected by a MCB and an EF protection

Photovoltaic power in: 3 phase + N + PE 400V/50Hz (grid-tied) protected by a MCB and EF protection

DC- Switching

- DC switch-isolator 2-pole isolator, double circuit.
- DC CB Capable of switching the rated current remotely.

AC - Switching

- AC switch isolator (outdoor use) IP65. For poles, 3+N. Rated for switching nominal current
- 2 x AC switch isolators (indoor use) Four pole, 3+N. Rated for switching nominal current
- 6 x CB's 3 pole breaking of current

Measurements

Cubicle	WxHxD	1050x1900x1075 mm
Weight		245 kg

....continuation PST2291 Solar Power Module

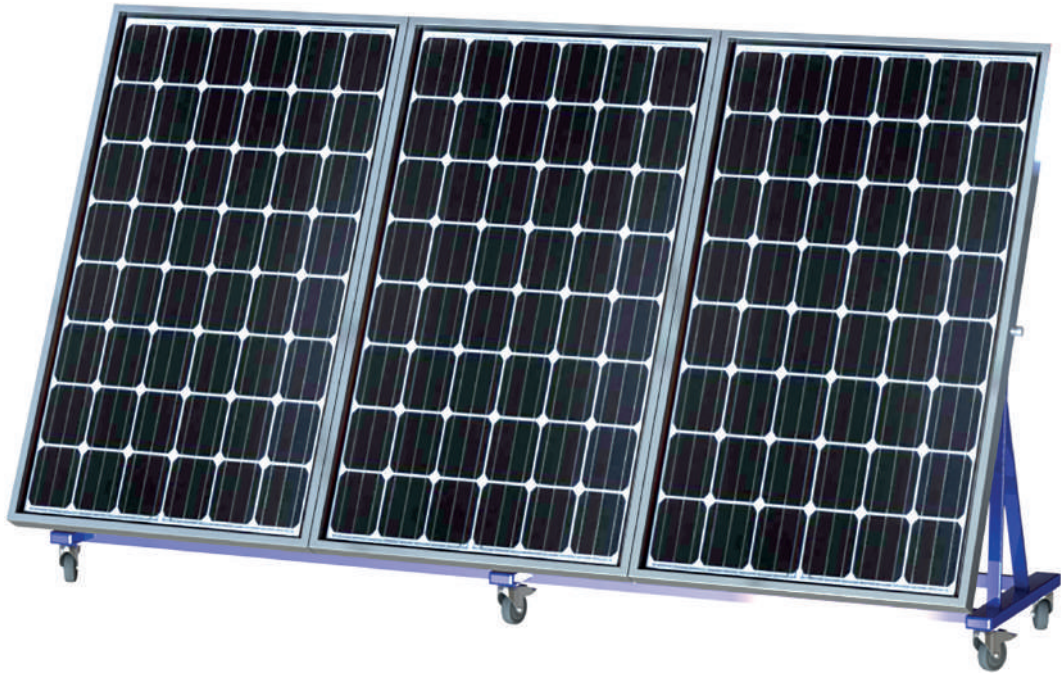

Photovoltaic Module

The photovoltaic module consists of three solar panels framed in a sturdy Aluminum frame, designed to be mounted on ground on a stand or on a roof top. The panels together with the electrical equipment are all IP65 or higher classed, making them suitable for outdoor use in all weather conditions.

Panels Specification

3 x monocrystalline:

- Aluminum frame, designed for environments with high temperature
- Maximum Power (P_{max}): 265W
- Short Circuit Current (typical A/lsc): 8.41
- Open Circuit Voltage (typical V/Voc): 37.7

Inverter

3 x micro inverter:

- A micro inverter accompanies to each panel in order to convert the DC to AC. 250W / inverter, Grid-tied

Sensors

Light sensor:

- Measures the amount of irradiance in the current
- Temperature sensor:
- Panel temperature

Panels

Three solar panels.

Each panel:

Measurements

Cubicle	WxHxD	1650 x 990 x 120 mm
		Dimension specifies panel folded down without wheels.
Weight		22 kg



PST2290 Wind Power Module

The PTG2290 Wind Power Module models the inherent principles, functions and challenges in the different stages of a wind power plant project. This includes both the operation of the individual wind turbine, as well as the connection of the plant to an electrical grid. It promotes hands-on experience in order to understand and overcome the challenges when incorporating modern renewable energy power plants into classic grid topologies.

The module includes an actual smallscale wind turbine that conveys the fundamental physical, mechanical and electrical principles when harvesting electrical energy from the wind. It is mounted on a 3 m mobile and foldable mast unit that allows quick and easy setup and repositioning at an optimal location in accordance with the local wind conditions.

Weather independent simulation is also made possible by a fully programmable variable three phase power source, integrated into the PTG2290 Wind Power Module. This allows full control over wind conditions even when the weather is calm, maximizing the efficiency of student lab time.

Additionally, a variable three phase electrical power source is integrated into the PTG2290 Wind Power Module, thus allowing the weather independent simulation of varying wind conditions and therefore maximizing the efficiency of student lab time.

Electrically, the module operates with a three phase permanent magnet alternator (PMA) connected to a three phase grid-tie inverter and includes all the necessary measuring, safety and display equipment for the operation of the wind power plant and execution of the provided experiments.

Aside from the three phase electrical data (voltage-current, active and reactive power as well as power factor), the data collected from the and included outdoor sensors on for wind speed, and wind direction, as well as air temperature and air pressure is displayed, logged and accessible for export.

The PST2290 Wind Power Module can function as stand alone equipment but can also easily be integrated into the Terco PTG and PST power system models and corresponding SCADA systems.

Technical Specifications

Wind turbine type	Vertical, Upwind
Rated power	1000 W
Max power 1	200 W
Rated rotation speed	750 rpm
Start-up wind speed	6 m/s
Rated wind speed	12 m/s
Survival wind speed	50m/s
Rotor diameter	1.96 m
Swept area	3 m ²
Generator	3-phase PMA
Grid-tie inverter type	

Gridtie inverter type	3-phase
Rated power	5.5 kW

Weight

Windmill	32 kg
Mast	95 kg

Dimensions

Windmill	1120 x 420 x 430 mm
Mast	1000 x 1000 x 400 mm



PST2250-150 TERCO SCADA System



To provide the best possible overview the system is delivered with 3 screens

Complete Laboratory Control and Monitoring System for the TERCO Power System Simulator PST 2200 including General Electric iFix Software package and computer.

iFIX is a superior proven real-time information management and SCADA solution, which is open, flexible and scalable. It includes impressive, latest generation visualization tools, a reliable control engine, and more.

Full system overview is provided via a tripple screen solution including user-selected page location.

As never before, this best in class software allows you to perform better analysis and leverage more reliability, flexibility, and scalability .

Complete access rights management and administration for both groups and individuals from Viewing Only to Full Control access of selectable modules.

Easy installation of additional power system modules for trouble-free future upgrades. Presentation of user-selected Trend Data for intuitive power system monitoring over time.

It is possible to connect multiple clients. Consequently multiple students can work simultaneously.

With the TERCO SCADA system, synchronization can be performed remotely at multiple points in the PST. Key parameters such as voltage and frequency are presented in real-time during the easy synchronization process.

All instruments, isolators and breakers, are indicated on screen even when operated from front panels. This facilitates for the teacher to study the work of the students without interfering.

The Equipment comprises:

- A. Advanced Measuring System connected on a local bus for instrumentation which through SCADA will reflect the real environment.
- B. PLC's to operate Isolators and Circuit Breakers together with auxiliary contactor functions for external connections.
- C. PLC's to control Generator Speed/Frequency and Voltage.
- D. Corresponding Software with Development Version License (Not only run-time).

Industrial SCADA system development version.

Features:

Indication Modules:

- Isolator and Breaker Status Control.
- Alarm Indications from Protection Relays.
- Extraction and Visualization of Disturbance Records

Full access to protections relays including parameter setting and Disturbance Records possible via a standard web browser.

It is possible to view important analogue current and voltage sinus waveforms in a suitable graph, together with protection's binary input and output status for in-depth fault analysis after such an event has occurred. Voltage and current vectors is presented alongside the graph with the possibility to scroll to any timepoint for simultaneous waveform and vector comparison.

Monitoring of system-wide power network characteristics occur via several industrial three-phase instruments, each comprising 20 parameters, such as:

- Voltage (ph-ph, ph-N, mean ph-ph, mean ph-N)
- Current (phases and mean) which enables the possibility to monitor non-symmetrical behaviour
- Active, reactive and apparent power (both phases and mean), cos phi etc.

.... continuation PST2250-150 TERCO SCADA System

Additional characteristics are monitored via single phase instruments, such as:

- Generator excitation current
- Voltage meters for bus bars

Remotely Controlled Modules:

- Motor (Turbine) Speed
- Generator Voltage
- Synchronization
- Loads
- Circuit Breakers
- Isolators
- Alarm Resetting
- Protection relay parameter settings
- Fault injections

Others:

- All Isolators and Circuit Breakers are interlocked by PLC's, to prevent faulty operation orders
- Replicates all PST 2200 System main module configurations
- Easily visualization of control and monitoring images
- Event logging (Alarm history)

The price includes the following:

- Complete hardware as above, software and software license
- Suitable high specification PC with 3 wide screens
- Manual covering essential descriptions
- Installation, commissioning and 1-2 days Basic Teacher Training at site by TERCO Engineer

Measurements:

Three screens per SCADA System as standard.

Each screen

Cubicle WxHxD 620x360x400 mm

Weight 5 kg

Computer (one computer per SCADA System):

Cubicle WxHxD 170x400x450 mm

Weight 6 kg

The dimensions and weights can vary slightly with any new screen and computer.

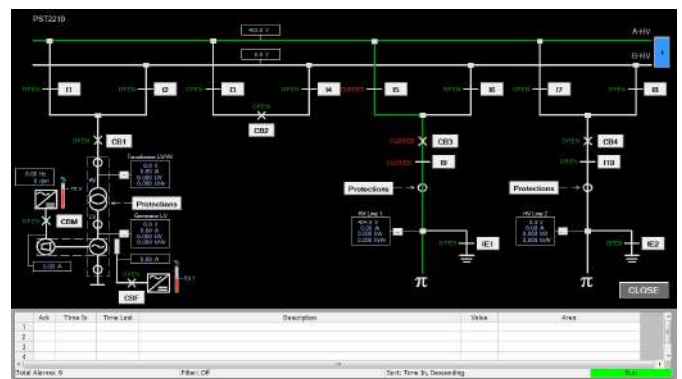
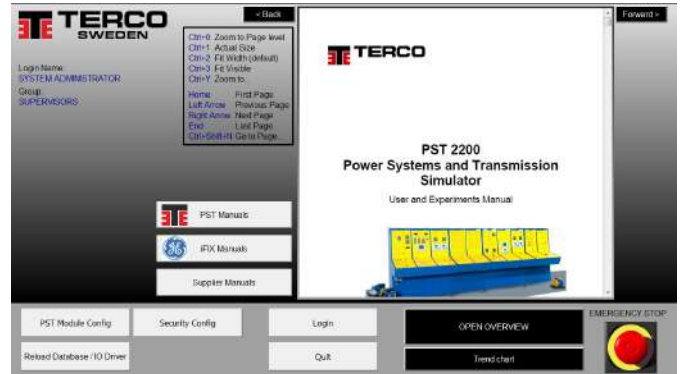

From the PST SCADA application (or Internet Explorer) the Protection Units can be accessed and configured by means of the ABB WHMI application (integrated in the Terco SCADA system). Below an example from the main page of a protection unit when a trip has occurred:

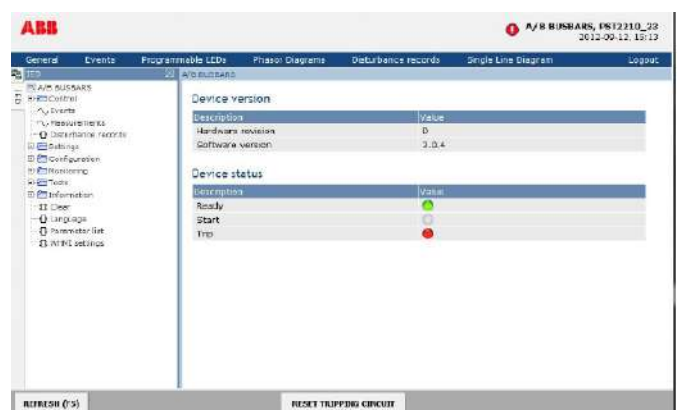

PST2252-1 SCADA Student Terminal



PST2252-1 SCADA Student Terminal contains:

- Suitable PC with wide screen
- Software license and communication card for connection to Master PC
- Necessary cables and components for connection to master PC in the same room

One SCADA Terminal can be able to control the whole PST system like the Master PC with the possibility to limit rights from Full Administrator Control to View Only Access.

This choice should be set from the Master PC via access rights management console.

Student Terminal requires SCADA iFix Master. Up to 64 students Terminals can be connected.

Full access to protections relays including parameter setting and Disturbance Records should be possible via a standard web browser.

It should be possible to view important analogue current and voltage sinus waveforms in a suitable graph, together with protection's binary input and output status for in-depth fault analysis after such an event has occurred.

Voltage and current vectors should be presented alongside the graph with the possibility to scroll to any timepoint for simultaneous waveform and vector comparison.

Measurements

Screen		
Cubicle	WxHxD	620x360x400 mm
Weight		5 kg
Computer		
Cubicle	WxHxD	170x400x450 mm
Weight		6 kg

The dimensions and weights can vary slightly with any new screen and computer.

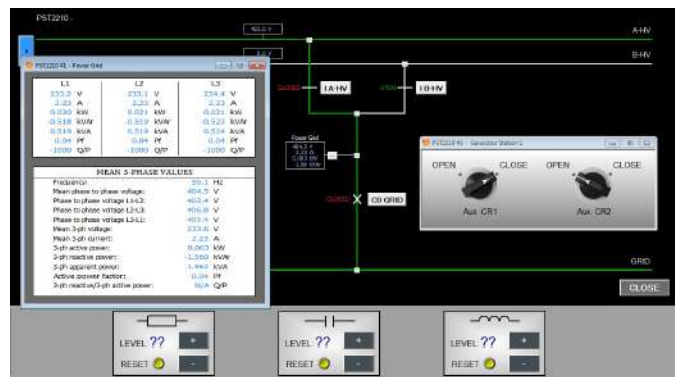
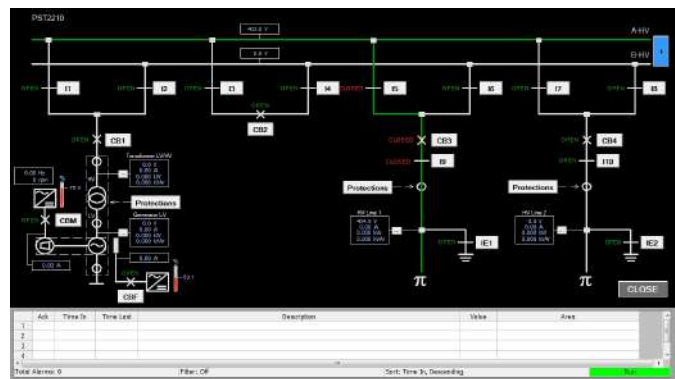
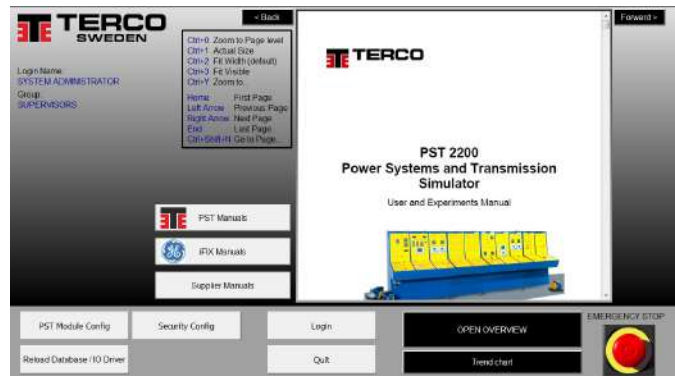

PST-Inst 1 Installation and Teacher Training



The installation is about 5 days and includes:

- Installation: TERCO presumes all necessary wiring and foundation to be ready according to instruction from TERCO prior to arrival of TERCO representative.
- Final Designation of Modules
- Electrical Internal Connection
- Electrical Installation to Main Supply
- Testing of Individual Modules
- Final Testing of the whole system.

All equipment packed in original crates. Unpacking are to be done together with TERCO representative.

The installation requires the support of one of your technicians.

Basic Teacher Training:

The proposed installation covers at the same time training with the system and presumes that the teachers are well familiar with electric power, theoretically and practically.

More comprehensive courses can be arranged at site or in Sweden and they can be tailor made according to customer requirement.

The training covers:

- Use of manual
- Technical Structure of the System including explanation of layout, external connections, internal connections and communication
- Starting, stopping and running the system for normal operation
- Operating the measuring systems
- Operating the CB and Isolators logical interlocking systems
- Performing a choice of experiments
- Performing a choice of network configurations
- The concept of synchronizing to a second generator or power source (if applicable)
- Fault Simulation Basic Service

ORDER DETAILS POWER SYSTEMS SIMULATOR

Order code	Description	Pcs Level 1	Pcs Level 2	Pcs Level 3	Page
PST2210-IED1	Power Plant Module, IED Level 1	1			8
PST2210-IED2	Power Plant Module, IED Level 2		1		8
PST2210-IED3	Power Plant Module, IED Level 3			1	8
PST2221	Transmission Lines Module	1	1	1	11
PST2222	Distribution Lines Module	1	1	1	14
PST2230-IED1	Receiving Substation Module, IED Level 1	1			12
PST2230-IED2	Receiving Substation Module, IED Level 2		1		12
PST2230-IED3	Receiving Substation Module, IED Level 3			1	12
PST2240	Load Module	1	1	1	15
PST2250-150	Terco SCADA System Master Module, 3 screen solution	1	1	1	24
Additional Modules					
PST2212	Mobile Additional Generator Module	1	1	1	17
PST2280	Power Factor Control Unit	1	1	1	16
PST2231	Power Grid Switchgear Module	1	1	1	19
Optional (one unit of each)					
PST2252-1	Terco SCADA System Student Module, 1 screen solution	1	1	1	26
Renewable Power modules					
PST2290	Wind Power Module	1	1	1	23
PST2291	Solar Power Module	1	1	1	21
Installation and Teacher Training					
PST-Inst 1	Installation and Basic Teacher Training	1	1	1	27

Ref. 101,102,103



Terco reserves the right to make changes in the design and modifications or improvements of the products at any time without incurring any obligations

PTG2000 Modular Power System

- **Power Generation**
- **Transmission**
- **Power Grid System**



The PTG2000 is a miniature system of production and distribution modules that can fit on a few meters of table surface. Each module itself can be studied. Together, the modules form an easy-to-manage, educational and comprehensible lab for controlling electrical energy.

PTG2000 General Description



The system consists of equipment that together form a mini power system showing how the power system works from production to consumer. The electric power system has two voltage sources consisting of synchronous generator and one from the existing power distribution network.

Furthermore, one or more transformers can be used to connect the generator and load points to the mains. The switchgear has dual buses and three feeders for incoming and outgoing lines.

The system can be connected to renewable energy sources (solar and wind) via a grid inverter. At this point, it is also possible to connect three or single-phase loads.

The unit is equipped with a large graphical Human Machine Interface (HMI) with a single line diagram.

Control, monitoring and parameter setting can be performed either from the HMI or from a PC by means of the standardized Ethernet interface.

The PTG1450 Line Multi Protection Trainer is equipped with the fully IEC61850 compliant ABB protection REF630 which is one of the most modern and sophisticated protection units in the product family of Intelligent Electronic Devices (IEDs).

The use of a highly advanced IED enables great possibilities to perform a wide range of laboratory experiments. This unit is intended for advanced training in modern line distance protection technology.

Features

- **Multiple Generators are possible.**
Motor 2.2 kW, Generator 1.2 kW
- **Active Load Sharing**
- **Grid System**
- **Colour coded power inlet / outlets for easy recognizing**
- **Mimic diagrams on the panels**
- **Solar/Wind Simulation 0,3 kW**
- **Basic and Advanced Relay Protection**
- **Power Factor Control of Transmission Lines**
- **Fully IEC61850 compliant ABB Relays**

Power supply and communication of modules

Local Area Network.



The modules Power Supply can be daisy-chained so that only one Power outlet is required

Every Module has two 1A fuse for Power Supply of the Module

Colouring of safety connections

EU ASIA, Middle East

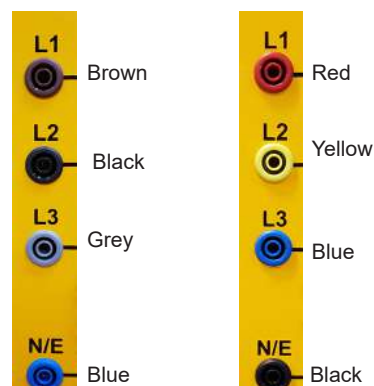

Note the difference in colour marking of phases and neutral conductors according to International Standards



MAIN

Mobile Motor / Generator Unit
page 8,9

Busbar page 15

LAN network for:

- SCADA Control & monitoring
- Disturbance Record Analysis via PC

LINE & PROTECTION

Line Multi Protection
page 12

π Line page 11

TRANSFORMER & PROTECTION

Differential Relay Protection
page 13

Transformer page 10

RENEWABLE ENERGY

Renewable Power Interface
page 15

Fault Connection
page 17

LINE

AC Meters
page 20

π Line page 11

π Cable Line page 11

SCADA Module
page 18

CONSUMER

Ind. load page 14

Res. load page 14

Cap. load page 14

Power Factor Control
page 16

Content in PTG2000 Level 1 with Variable Transformer and Connection Box

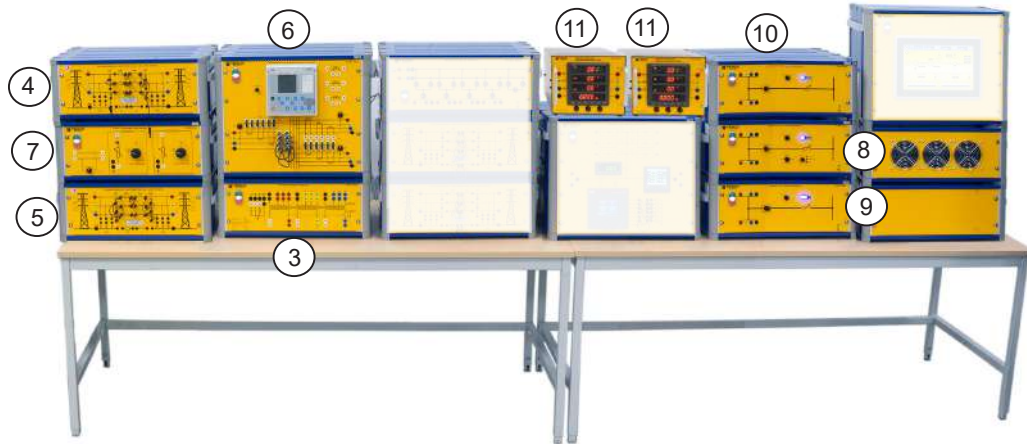

- ① MV1103 Variable Transformer 3-phase
- ② MV1429 Connection Box / Terminal Board
- ③ PTG1965 Transformer Module
- ④ PTG1521 Transmission HV OH-Line 230 kV, 100 km
- ⑤ PTG1523 Transmission HV OH-Line 35 kV, 20 km
- ⑥ PTG1455 Differential Relay Module
- ⑦ PTG1570 Fault Connection Module
- ⑧ PTG1560 Resistive Load Module 400V, 1,5 kW in 15 steps
- ⑨ PTG1561 Inductive Module 400V, 2,5 kVAr in 15 steps
- ⑩ PTG1562 Capacitor Load Module 400V, 2,8 KVAR in 15 steps
- ⑪ PTG1939 AC Power Energy Meter
- ⑫ MAT220118 Digital Multimeter
- ⑬ MAT220350 Digital Clamp Meter AC / DC current
- ⑭ MV1801-HF Flex Set 200 pc Safety Leads 5 colours
- ⑮ MV1904 Flex Stand

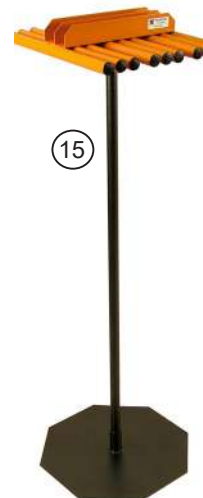

**PTG2000 Level 1, 2 and 3 are examples of standard setup.
For more information about content and setup of your own
Laboratory, please contact us.**

Content in PTG2000 Level 2 with Mobil Motor/Generator Module

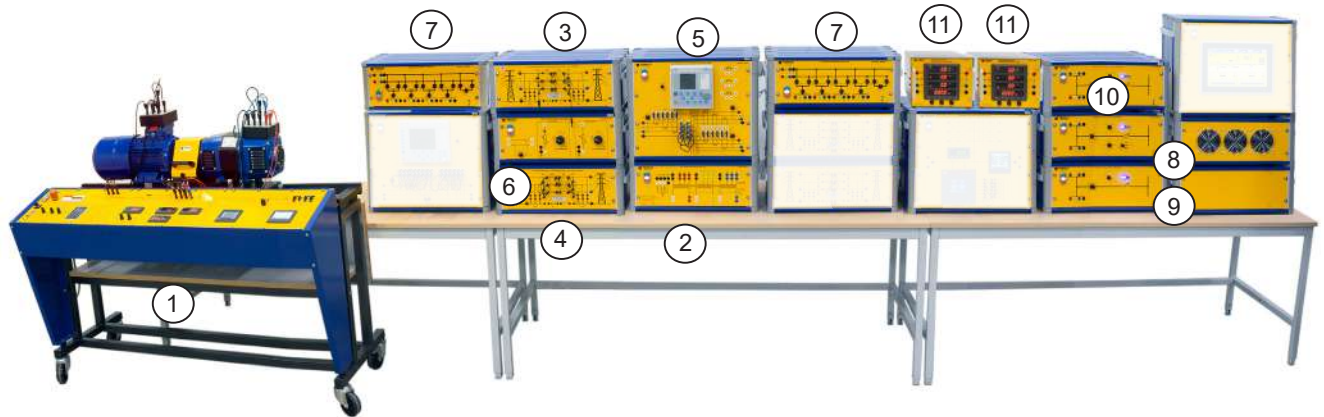

12



14



- 1 PTG1305 Mobil Motor / Generator Module
- 2 PTG1965 Transformer Module
- 3 PTG1521 Transmission HV OH-Line 230 kV, 100 km
- 4 PTG1523 Transmission HV OH-Line 35 kV, 20 km
- 5 PTG1455 Differential Relay Trainer
- 6 PTG1570 Fault Connection Module
- 7 PTG1565 Double Busbar Module with 4 feeders
- 8 PTG1560 Resistive Load Module 400V, 1,5 kW in 15 steps
- 9 PTG1561 Inductive Module 400V, 2,5 kVAr in 15 steps
- 10 PTG1562 Capacitor Load Module 400V, 2,8 kVAr in 15 steps
- 11 PTG1939 AC Power Energy Meter
- 12 MAT220118 Digital multimeter
- 13 MAT220350 Digital Clamp Meter AC / DC current
- 14 MV1801-HF Flex Set 200 pc Safety Leads 5 colours
- 15 MV1904 Flex Stand



**PTG2000 Level 1, 2 and 3 are examples of standard setup.
For more information about content and setup of your own
Laboratory, please contact us.**

Content in PTG2000 Level 3 Extended and Advanced System

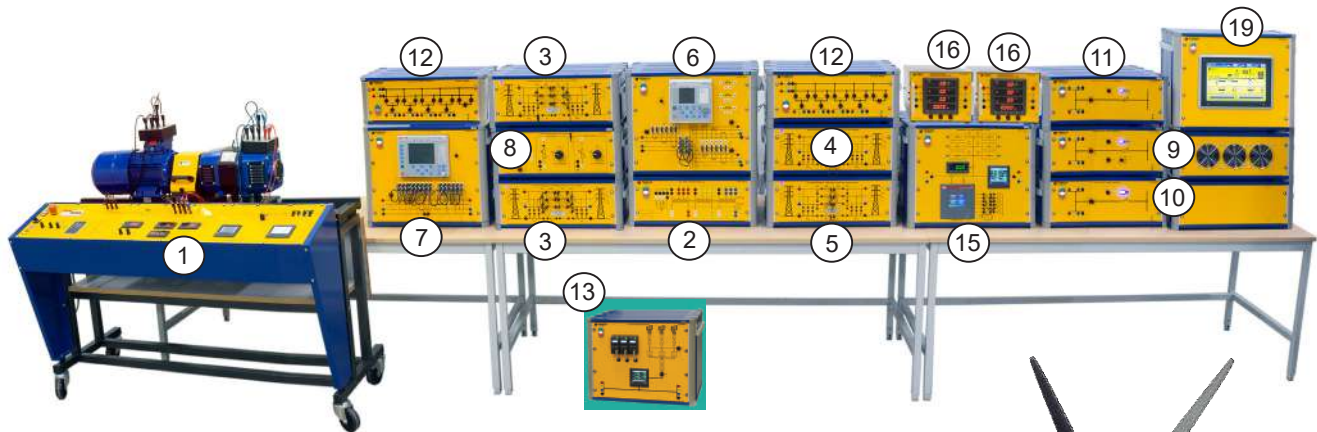

- ① PTG1305 Mobil Motor / Generator Module
- ② PTG1965 Transformer Module
- ③ PTG1521 Transmission HV OH-Line 230 kV, 100 km
- ④ PTG1523 Transmission HV OH-Line 35 kV, 20 km
- ⑤ PTG1522 Transmission Cable MV Line 11 kV, 5km
- ⑥ PTG1450 Line Multi Protection Trainer
- ⑦ PTG1455 Differential Relay Trainer
- ⑧ PTG1570 Fault Connection Module
- ⑨ PTG1560 Resistive Load Module 400V, 1,5 kW in 15 steps
- ⑩ PTG1561 Inductive Module 400V, 2,5 kVar in 15 steps
- ⑪ PTG1562 Capacitor Load Module 400V, 2,8 KVAR in 15 steps
- ⑫ PTG1565 Double Busbar Module with 4 feeders
- ⑬ PTG2291 Solar Power Module (incl. stand for outdoor use)
- ⑭ PTG2290 Wind Mill Module (incl. Wind Mill for outdoor operation)
- ⑮ PTG1439-405 Power Factor Control Module
- ⑯ PTG1939 AC Power Energy Meter
- ⑰ MAT220118 Digital Multimeter
- ⑱ MAT220350 Digital Clamp Meter AC / DC current
- ⑲ PTG1631 SCADA System
- ⑳ MV1801-HF Flex Set 200 pc Safety Leads 5 colours
- ㉑ MV1904 Flex Stand

PTG2000 Level 1, 2 and 3 are examples of standard setup. For more information about content and setup of your own Laboratory, please contact us.



PTG1305 Mobile Motor / Generator Unit



Technical Specification

Power Supply:

Voltage	380-415 V AC 3-ph
Frequency	50 Hz/60Hz
Max current	16 A

Turbine/AC-machine freq.drive:

Armature/stator Volt	323-528 V AC
Frequency	47-63 Hz
Armature/stator current	3.4 A
Input current	5.9 A
Rated output current	4.0 A
Rated output capacity	3.2 kVA
Speed	0-1800 rpm

Speed control/

Speed	0-1800 rpm
Active power control:	Frequency converter, electronic current limit setting, start- and stop ramps.
Feedback systems	Manual frequency setting. Automatic/Constant setting
Field current supply	Integrated

Synchronous generator:

Armature volt	0-140 / 240 V AC
Power	1.2 kVA
Cos ϕ	0.8
Field volt	0-230 V DC

Voltage control/

Reactive power control	PWM min. ripple-converter, electronic current limit setting
Feedback systems	Manual voltage setting. Automatic/Constant setting. Separate voltage feedback

PTG1305 Mobile Motor / Generator Unit

A standard laboratory for power transmission normally consists of one or two generators, which are connected to one or more transmission links which finally reach transformers, distribution units and loads.

For example, here can be seen turbine/generators in parallel on the same busbar, a synchronous machine used as a synchronous compensator in the middle of a line, a single generator unit and a heavy group of generators.

Energy transfer, load shedding, static and dynamic stability at disturbances as well as sophisticated protection schemes can be studied under realistic forms. Not to forget compensation possibilities.

Power and current paths in grid networks are complicated. The TERCO system will give understanding for these problems. Wide range of flexibility is achieved by the mobile generator station / synchronous alternator (compensator) PTG1305. Two sets of PTG1305-405 can operate as described or work in parallel.

Modes of Operation

PTG1305-405 can also be used to compensate for system power characteristics (active and reactive) via turbine speed and generator magnetisation.

The Mobile Motor / Generator Module is equipped with Local Area Network communication for monitoring via PTG1631 SCADA Module. Relevant faults can be connected for troubleshooting exercises via PTG1570 Fault Module

Instruments:

AC-machine freq.drive
(Turbine simulator)

Parameters and indications selected by 4-lines display in HMI-unit for example:

- Frequency setpoint 50Hz
- Stator Electric Frequency 50Hz
- Actual motor speed (from encoder) 1500 rpm at 50Hz, 1800 rpm at 60Hz
- Motor current 2,20 A
- DC-interlink voltage 520 V
- Speed control potentiometer (=frequency control)
- Feedback selector (Auto/ Man)

AC-machine M/G

- Armature voltage
- Voltage selector switch
- Armature current
- Voltage control potentiometer
- Feedback selector (Auto/ Man)
- Field current ammeter

Synchronizing device

- Synchronizing instrument
- Double voltmeter Δu
- Double frequency meter Δf
- Synchronizing switch
- Automatic or manual synchronizing

Auxiliary

- Machines mounted on machine bed with Slid rails.
- Control panel integrated with machines to one mobile unit.
- Laboratory connections by 4 mm safety plugs. Possibilities of connecting different types of step-up transformers as well as other instruments and protections.

Dimensions 1550 x 800 x 1200 mm

Weight 200 kg (approx.)

Voltage and frequency variants

Product no	Power Supply	Synchronous Generator
PTG1305-405-235	400V 3-ph, 50Hz	230V 3-ph, 50Hz
PTG1305-406-236	400V 3-ph, 60Hz	230V 3-ph, 60Hz
PTG1305-405-405	400V 3-ph, 50Hz	400V 3-ph, 50Hz
PTG1305-406-406	400V 3-ph, 60Hz	400V 3-ph, 60Hz

Transformer

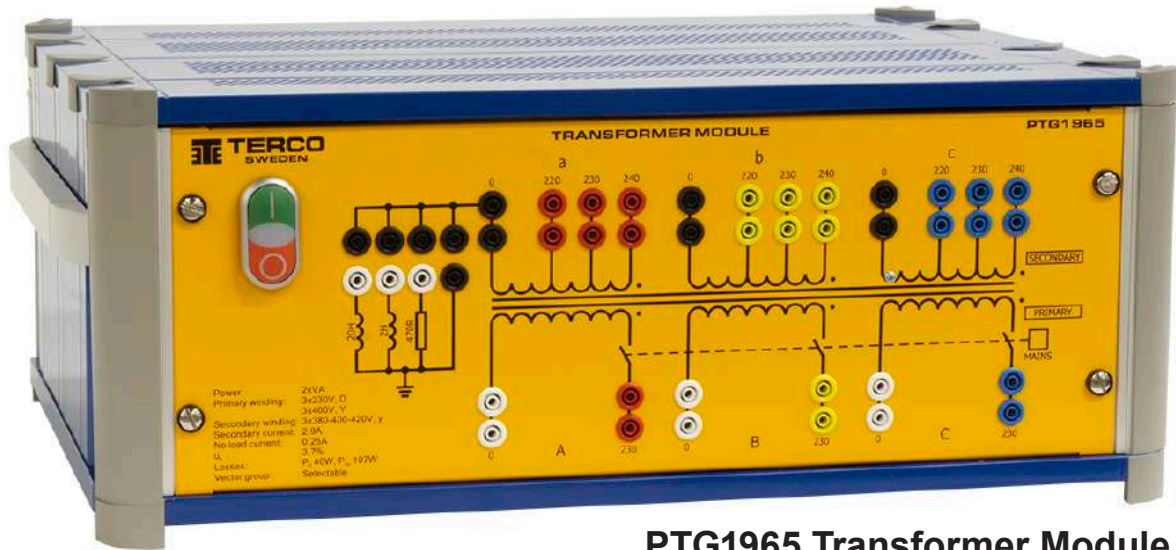

PTG1965 Transformer Module

Between the grid and generator station connects a generator. The transformer allows the user to configure the transformer with different vector groups such as Dyn / Yyn and so forth.

Technical Specifications

Power Supply:	1-ph 220 - 240 V, 50 - 60 Hz
Three-phase:	2 kVA, 50-60 Hz
Primary:	3 x 230V D, 3 x 400V, Y
Secondary:	3 x 380-400-420V, y
Secondary current:	2.9A
No load current:	0.25A
U_k :	3.7%
Losses:	$P_o=40W$, $P_{cu}=107W$
Vector group:	Selectable
Dimension:	560 x 420 x 205 mm
Weight:	48 kg



PTG1939 AC Power Energy Meter

PTG1939 AC Power Energy Meter is a practical solution for the study of 1, 2 and 3-Phase AC power systems up to 500VAC/10A.

The Power Energy Meter enables the measurement and visualization of a wide range of parameters in the study of symmetrical as well as non-symmetrical networks, such as:

- phase voltages
- phase-to-phase voltages
- line currents
- mean three-phase current
- mean three-phase voltage
- mean phase-to-phase voltage
- three-phase active
- reactive and apparent powers
- mean three-phase power factors.

The visualization of parameters is distributed over several pages (default preset to display five pages) where each page simultaneously displays four parameters.

PTG1939 AC Power Energy Meter

Technical Specifications

Power supply	220-240VAC, 50/60Hz
Measurement ratings:	
Voltage / Current	500VAC max / 10AAC max
Reactive / Active Power	5 kVAR / 5 kW
Cos Phi	0-1-0
Communications:	
Serial interface	RS485
Transmission protocol	Modbus RTU8N2
Baud Rate	19200kB
Dimension	255 x 205 x 335mm
Weight	10kg

PTG1520-1524 Transmission / Distribution OH Line Modules

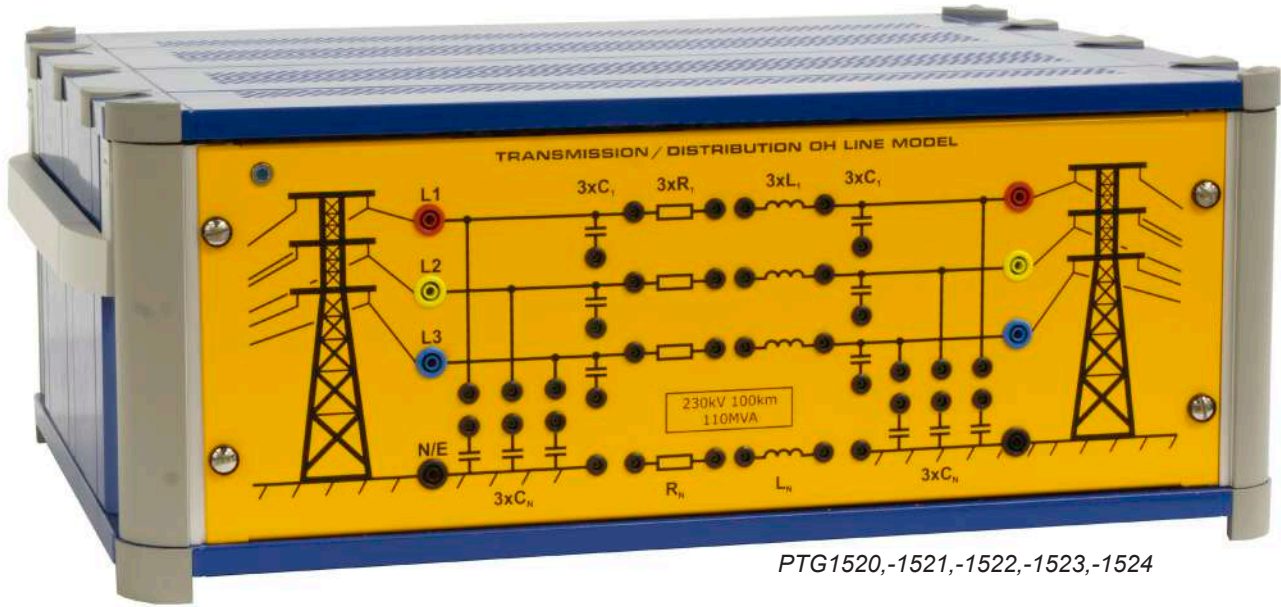

PTG1520,-1521,-1522,-1523,-1524

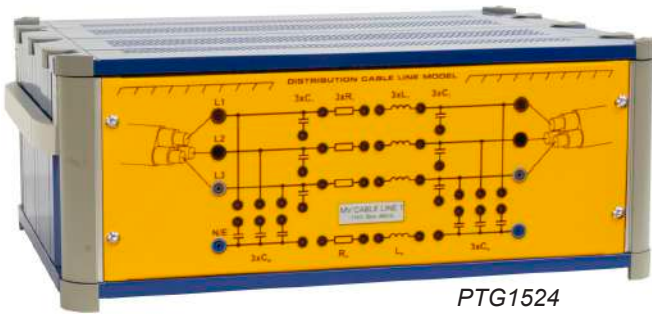

PTG1524

The Transmission Lines have scaled down 3-phase OH transmission lines with different values. For each Line it is possible to change and combine impedance elements to constitute other Overhead Lines (OH) High Voltages (HV) levels.

On the request other line values are possible to order.

All models have inductors, capacitors and resistors designed to withstand overload and surges for dynamic as well as for static experiments.

All parameters of the transmission models can be changed easily by both internal and external combinations, together with the possibilities of arranging the models in series, parallel or in grid networks.

Each line model consists of a three-phase pi-link and an earth link.

A safety switch is incorporated on the backside to ensure earthing of the Module

With our Transmission Line Modules, we have a unique combination of HV-lines, Medium-Voltage lines, OH-distribution Voltage lines and Distribution Voltage cables which will enable studies of the typical parameters and characteristics within the four main groups of AC-power transmission and corresponding need of compensation.

It is possible to isolate/separate the different R, L, and C characteristics of each line for individual analysis.

Relevant errors can be programmed for troubleshooting exercises via PTG1570 Fault Module

Technical Specification

PTG1520	OH-HV π -link	77 kV	13 MVA	136 km
PTG1521	OH-HV π -link	230 kV	110 MVA	100 km
PTG1522	OH-HV π -link	11 kV	4MVA	5 km
PTG1523	OH-HV π -link	11 kV	5 MVA	20 km
PTG1524	Cable MV π -link	33 kV	20 MVA	20 km

Power Supply: 1-ph 220 - 240 V, 50 - 60 Hz

Power bus: 3-phase 400V AC/ 2A with 4 mm safety connectors.

Weight: 50 kg 420 x 205 mm

Terco reserves the right to make changes in the design and modifications or improvements of the products at any time without incurring any obligations

Protective Modules - Fully IEC 61850 compliant

PTG1450 Line Multi Protection Module



General Features

- Colour coded power inlet- and outlets for easy recognition of each phase.
- Mimic diagrams of the circuit along with large clear symbols printed on the front panel

Power bus circuit breaker switch:

- A two state switch (ON/OFF) with LED indication of CB (Circuit Breaker) status.
- Internal circuitry prevents operation of the CB during an unacknowledged trip.

Trip reset button:

- Button for quick reset of LEDs and acknowledgement of a trip.
- Control, monitoring and protection integrated in one IED
- Fully IEC 61850 compliant.
- Four independent parameter setting groups.
- Large HMI with single line diagram.
- RJ-45 interface for communication with PC.
- Protection and Control IED Manager PCM600: Advanced software for configuration and parameter setting.

The PTG1450 Line Multi Protection Trainer module is intended for advanced training in modern line distance protection technology.

It is equipped with the fully IEC61850 compliant ABB protection REF630 which is one of the most modern and sophisticated protection units in the product family of Intelligent Electronic Devices (IEDs).

REF630 is designed for protection of transmission and distribution networks.

The use of a highly advanced IED enables great possibilities to perform a wide range of laboratory experiments.

Relevant faults can be connected for troubleshooting exercises via PTG1570 Fault Module.

The protective relay REF630 used in PTG1450 enables the student to learn and explore how to protect a variety of different power line configurations from various fault conditions.

Technical Specification

Power Supply:	1-ph 220 - 240 V, 50 - 60 Hz
	Possible to supply a compatible device with power (at page 3)
Power bus:	3ph, 400VAC, 2A
Dimension:	560 x 420 x 430 mm
Weight:	37 kg

Protective earth: one 4mm safety connector for external components at the rear of the unit.

REF630 Important Protection functions

- Capable of a 5 zone full-scheme high-speed line distance protection with mho^*), bullet and quadrilateral characteristics.
- Three stages of over-current protection (Low, high and instantaneous)
- Directional earth-fault protection
- Over-voltage protection
- Over-power protection (configurable direction)

**) In order to retain dependability and security in cases of close-in faults when the loop voltage is zero, mho distance elements use cross-phase and/or memory polarization.*

Full access to protection relays including parameter setting and Disturbance Records is possible via a standard web browser.

It is possible to view important analogue current and voltage sinus waveform vectors in a suitable diagram, together with protection binary input and output status for in-depth fault analysis after such an event has occurred.

SCADA ready for remote control of Circuit Breaker and Trip Reset via HMI

PTG1455 Differential Relay Module



General Features

- Colour coded power inlet- and outlets for easy recognition of each phase.
- Mimic diagrams of the circuit along with large clear symbols printed on the front panel.

Power bus circuit breaker switch:

- A two state switch (ON/OFF) with LED indication of CB (Circuit Breaker) status.
- Internal circuitry prevents operation of the CB during an unacknowledged trip.

Trip reset button:

- Button for quick reset of LEDs and acknowledgement of a trip.
- Control, monitoring and protection integrated in one IED
- Fully IEC 61850 compliant.
- Four independent parameter setting groups.
- Large HMI with single line diagram.
- RJ-45 interface for communication with PC
- Three power lines; 1 incoming power line and 2 outgoing. Each line contain three phases L1, L2, L3 and Neutral wire.
- 12 Current Transformers which enables the student to study various CT-connections.
- Protection and Control IED Manager PCM600: Advanced software for configuration and parameter setting.
- Front panel switches that enable the student to test differential protection on a double-busbar.

The PTG1455 Differential Relay Module module is intended for advanced training in modern differential protection technology.

It is equipped with the fully IEC61850 compliant ABB RET615 protective relay which is one of the most sophisticated protection unit in the product family of intelligent electronic devices (IEDs).

RET615 is designed for differential protection of transformers, generators, line sections and their combinations.

The use of a highly advanced IED enables great possibilities to perform a wide range of laboratory experiments.

Relevant faults can be connected for troubleshooting exercises via PTG1570 Fault Module.

The protective relay RET615 used in PTG1455 enables the student to learn and explore how to protect a variety of different power transformer connections with a differential protection scheme.

Technical Specification

Power Supply: 1-ph 220 - 240 V, 50 - 60 Hz
 Power bus: (3-ph) 400V AC/ 2A with 4 mm safety connectors

Dimension: 560 x 420 x 430 mm
 Weight: 37 kg

Protective earth: one 4mm safety connector for external components at the rear of the unit.

RET615 Important Protection Functions

- Differential Fault Protection
- Three-phase non-directional overcurrent protection, low, high and instantaneous stage
- Non-directional earth-fault protection, low and high stage
- Negative-sequence overcurrent protection
- Residual overvoltage protection

Full access to protection relays including parameter setting and Disturbance Records is possible via a standard web browser.

It is possible to view important analogue current and voltage sinus waveform vectors in a suitable diagram, together with protection binary input and output status for in-depth fault analysis after such an event has occurred.

SCADA ready for remote control of Circuit Breaker and Trip Reset via HMI

Loads



PTG1560 Resistive Load Module

The load can be changed in 15 steps with 100W / step at 400V. Totally 1500 W.

The unit can be programmed for a typical load curve over 24 hours.

Power Supply:	1-ph 220 - 240 V, 50 - 60 Hz
Input Voltage:	3-phase 400V AC/ 2A with 4 mm safety connectors.
Dimension:	560 x 420 x 430 mm
Weight:	38 kg

PTG1560 consists of 2 units which can be split to optimize the bench top place.



PTG1561 Inductive Load

PTG1561 is housed in a metal cabinet with electrical data and symbols on the front panel. Both the 50 and 60Hz variants charge 1.5 kVAr and are Y-connected.

PTG1561 Inductive Load for 50 / 60Hz

Power Supply:	1-ph 220 - 240 V, 50 - 60 Hz
Current:	0.15-2.2A / 0.12-1.8 A
Input Voltage:	3-phase 400V 50Hz / 2A with 4 mm safety connectors

Dimension:	560 x 420 x 430 mm
Weight:	40 kg

PTG1561 consists of 2 units which can be split to optimize the bench top place.



PTG1562 Capacitor Load Module

PTG1562 is housed in a metal cabinet with electrical data and symbols on the front panel. Both the 50 and 60Hz variants charge 1.5 kVAr and are Y-connected.

PTG1562 Capacitive Load for 50Hz / 60Hz

Power Supply:	1-ph 220 - 240 V, 50 - 60 Hz
Current:	0.15-2.2A / 0.18-2.6A
Input Voltage:	3-phase 400V 50Hz / 2A with 4 mm safety connectors

Dimension:	560 x 420 x 205 mm
Weight:	15 kg

Power Components



PTG1565 Double Busbar Module

This unit is a double busbar module where the user has access to 4 feeders for incoming/outgoing power. Each feeder is connected to the two busbars through two isolators and one circuit breaker. Internal logic prohibits the user from incorrect switching (i.e breaking current with an isolator). This module can be used in the laboratory to assemble a larger power grid.

Relevant faults can be connected for troubleshooting exercises via PTG1570 Fault Module

Power Supply: 1-ph 220 - 240 V, 50 - 60 Hz
 Power bus: 3-phase 400V AC/ 2A with 4 mm safety connectors.

Dimension: 560 x 420 x 205 mm
 Weight: 10 kg

Fault Connection Module



PST1570 Fault Connection Module

is a fault simulator with the ability to simulate many different types of variable short circuit and earth faults. The maintained / momentary switch allows safe and secure connection of permanent or instantaneous faults

Impedance errors can be connected individually, in parallel or in series.

PTG1570 is used together with Line Multi Protection Trainer and Differential Protection Trainer

Power supply: 1-ph 220 - 240 V, 50 - 60 Hz
 Dimension: 560 x 420 x 205 mm
 Weight: 15 kg

All Load Modules are equipped with Local Area Network communication for monitoring and control via PTG1631 SCADA Module.

Relevant errors can be programmed for trouble shooting exercises via PTG1570 Fault Module

PTG1439-405 Power Factor Control Unit



General

With the Power Factor Control Module (PFC) you can minimise the currents caused by reactive losses of power thereby optimising the transfer of energy between generation and loading.

This is becoming more and more important today when "Saving energy" is vital in a world with focus on pollution and shortage of energy.

Field of application

Inductive or mixed inductive and resistive networks in need of compensation, for example when starting and running induction motors as in industrial applications.

Principles of operation

Depending on the power factor of the loading network a microprocessor will connect groups of capacitors. By measuring phase voltages and current the microprocessor will calculate how many capacitive groups that has to be connected and also in which combinations.

Electrical details

Number of 3-ph groups 6 capacitive
Power factor setting: 0 to 0.7

MV1439-235 nominal voltage 3 x 230V, 50-60 Hz
MV1439-405 nominal voltage 3 x 400V, 50-60 Hz

Nominal voltage: 3 x 400 V 50 – 60 Hz
Nominal power: 0 – 2 kVAr capacitive
PF-Controller: Automatic or manual
Adjustable delay times, switching sequences and strategies.

Monitoring and Measurement on the controller:

Voltage, Current and Power factor

Switching modes: Linear and circular

Indication lamps: Indication lamps for the capacitor groups which are connected

Physical design

The Power Factor Control Unit is housed in a sturdy apparatus box with a clear mimic diagram explaining how to connect the supplying net from the left to the right side where the network in need for power factor compensation is connected.

Readings, parameters and sub parameters are indicated on the front of the controller. Other settings and programming than the defaults are simply performed from the keyboard and displayed on the controller front.

General data:

Power supply: 1-ph 220 - 240 V, 50 - 60 Hz
Dimension: 560 x 420 x 430 mm
Weight 24 kg

Typical Experiments with Terco PFC:

- The concept of active power, apparent power and reactive power
- The concept of power factor and $\cos \varphi$
- The concept of measuring methods
- Start current settings (C/k)
- Delay times
- Efficiency and losses
- Linear and circular switching modes
- PF-Controller design and schematics
- Programming the controller
- PF-Controller and resistive/inductive loads
- PF-Controller and induction motor loads
- Control range limits

PTG2291 Solar Power Module



General Data

Power Supply:	240V 3-phase, 10A. Each module connects 3 pole (L1, N, Earth)
Cubicle Weight	560 x 420 x 430 mm 24 kg



General

PTG2291 is a free standing module with the same form factor as the other modules.

PTG2291 is a generator station where the generator consists of three solar panels delivering three-phase power to the module that can further be tied to a grid.

The module simulates a solar farm, containing all necessary equipment such as solar panels, inverters, switchgear, protection modules and voltage transformation before interfacing the grid.

A Solar Farm provides a variety of switching equipment that handles control and switching of both AC and DC.

Technical Specifications

Electrical Data

Rear side I/O:	1 phase + N + PE 230V/50Hz protected by a Fuses
Photovoltaic power in:	3 phase + N + PE 400V/50Hz (grid-tied) protected by a MCB and EF protection

DC- Switching

- DC CB Capable of switching the rated current remotely.

AC - Switching

- 6 x CB's 3 pole breaking of current

Photovoltaic Module

The photovoltaic module consists of three solar panels framed in a sturdy Aluminum frame, designed to be mounted on ground or on a roof top. The panels together with the electrical equipment are all IP65 or higher classed, making them suitable for outdoor use in all weather conditions.

Panels Specification

3 x monocrystalline:	
• Maximum Power (P_{max}):	265W
• Short Circuit Current (typical A/Isc):	8.41
• Open Circuit Voltage (typical V/Voc):	37.7

Inverter

3 x micro inverter to convert the DC to AC. 250W / inverter, Grid-tied.

Measurements

Each panel incl. stand	
Cubicle WxHxD	1650 x 990 x 120 mm Dimension specifies panel folded down without wheels.
Weight	52 kg per panel

PTG2290 Wind Power Module

The PTG2290 Wind Power Module models the inherent principles, functions and challenges in the different stages of a wind power plant project. This includes both the operation of the individual wind turbine, as well as the connection of the plant to an electrical grid. It promotes hands-on experience in order to understand and overcome the challenges when incorporating modern renewable energy power plants into classic grid topologies.

The module includes an actual smallscale wind turbine that conveys the fundamental physical, mechanical and electrical principles when harvesting electrical energy from the wind. It is mounted on a 3 m mobile and foldable mast unit that allows quick and easy setup and repositioning at an optimal location in accordance with the local wind conditions.

Weather independent simulation is also made possible by a fully programmable variable three phase power source, integrated into the PTG2290 Wind Power Module. This allows full control over wind conditions even when the weather is calm, maximizing the efficiency of student lab time.

Additionally, a variable three phase electrical power source is integrated into the PTG2290 Wind Power Module, thus allowing the weather independent simulation of varying wind conditions and therefore maximizing the efficiency of student lab time.

Electrically, the module operates with a three phase permanent magnet alternator (PMA) connected to a three phase grid-tie inverter and includes all the necessary measuring, safety and display equipment for the operation of the wind power plant and execution of the provided experiments.

Aside from the three phase electrical data (voltage-current, active and reactive power as well as power factor), the data collected from the and included outdoor sensors on for wind speed, and wind direction, as well as air temperature and air pressure is displayed, logged and accessible for export.

The PTG2290 Wind Power Module can function as stand alone equipment but can also easily be integrated into the Terco PTG and PST power system models and corresponding SCADA systems.

Technical Specifications

Wind turbine type	Vertical, Upwind
Rated power	1000 W
Max power 1	200 W
Rated rotation speed	750 rpm
Start-up wind speed	6 m/s
Rated wind speed	12 m/s
Survival wind speed	50m/s
Rotor diameter	1.96 m
Swept area	3 m ²
Generator	3-phase PMA
Grid-tie inverter type	

Gridtie inverter type	3-phase
Rated power	5.5 kW

Weight

Windmill	32 kg
Mast	95 kg

Dimensions

Windmill	1120 x 420 x 430 mm
Mast	1000 x 1000 x 400 mm



PTG1631 SCADA System



Technical specifications

HMI

Housing material: Powder-coated aluminum, Gray
 Screen: TFT-LCD 12", 1280x800 px
 Class I (ISO9241-307)
 LED Backlight and Industrial dimming
 Resistive Touch Screen
 Full colour

PTG1631 SCADA System Module includes an advanced and stylish industrial standard HMI where measurement data from throughout the power system is collected, logged and presented.

Power system characteristics can be monitored and investigated in real-time on attractive virtual instruments. Time-lapse data tracked and presented clearly in trend charts and values stored in the data logger can be saved and exported for further investigation at a later date. Clear indications of important system events help operators to understand the complicated relationships and balance required between modern components, in order to maintain a robust power supply.

PTG1631 SCADA System Module is designed to work with multiple PTG1939 Power Energy Meters. These measurement instruments provide information of over 30 3-phase parameters each and are connected via a LAN network.

The HMI can even be accessed and controlled remotely from a PC via a VNC Viewer. This allows for further presentation via projector, large-screen t.v. or other device.

Power supply: 1-ph 220 - 240 V, 50 - 60 Hz

Dimension: 560 x 420 x 430 mm

Weight 17 kg

ORDER DETAILS POWER GENERATION AND GRID MODULAR SYSTEM

Order code	Description	Pcs Level 1	Pcs Level 2	Pcs Level 3	Page
MV1103	Variable Transformer, 3-phase	1			177
MV1429	Connection Box / Terminal Board	1			218
PTG1305-405	Mobil Motor / Generator Module		1	1	35
PTG1965	Transformer Module	1	1	1	37
PTG1521	Transmission HV OH Line 230 kV, 100 km	1	1	1	38
PTG1523	Transmission MV OH Line 35 kV, 20 km	1	1	1	38
PTG1522	Transmission Cable MV Line 11 kV, 5 km			1	38
PTG1450	Line Multi Protection Trainer			1	39
PTG1455	Differential Relay Trainer	1	1	1	40
PTG1570	Fault Connection Module	1	1	1	42
PTG1565	Double Bus bar Module with 4 feeders		2	2	42
PTG1560	Resistive Load Module 400 V, 1,5 kW in 15 steps	1	1	1	41
PTG1561	Inductive Load Module 400V, 2,5 kVAr in 15 steps	1	1	1	41
PTG1562	Capacitor Load Module 400 V, 2,8 kVAr, in 15 steps	1	1	1	41
PTG2291	Solar Power Module			1	44
PTG2290	Wind Mill Module			1	45
PTG1439-405	Power Factor Control Module			1	43
PTG1939	AC Power Energy Meter	2	2	2	37
MAT220118	Digital Multimeter	1	1	1	191
MAT220350	Digital Clamp Meter AC / DC current	1	1	1	188
PTG1631	SCADA System Module			1	46
MV1801-H	Flex Set 200 Safety Leads 5 colours	1	1	1	198
MV1904	Flex Stand	1	1	1	199

Electrical Machines Laboratory

- **Electrical Machines**
- **Drives**
- **Power Factor Control**

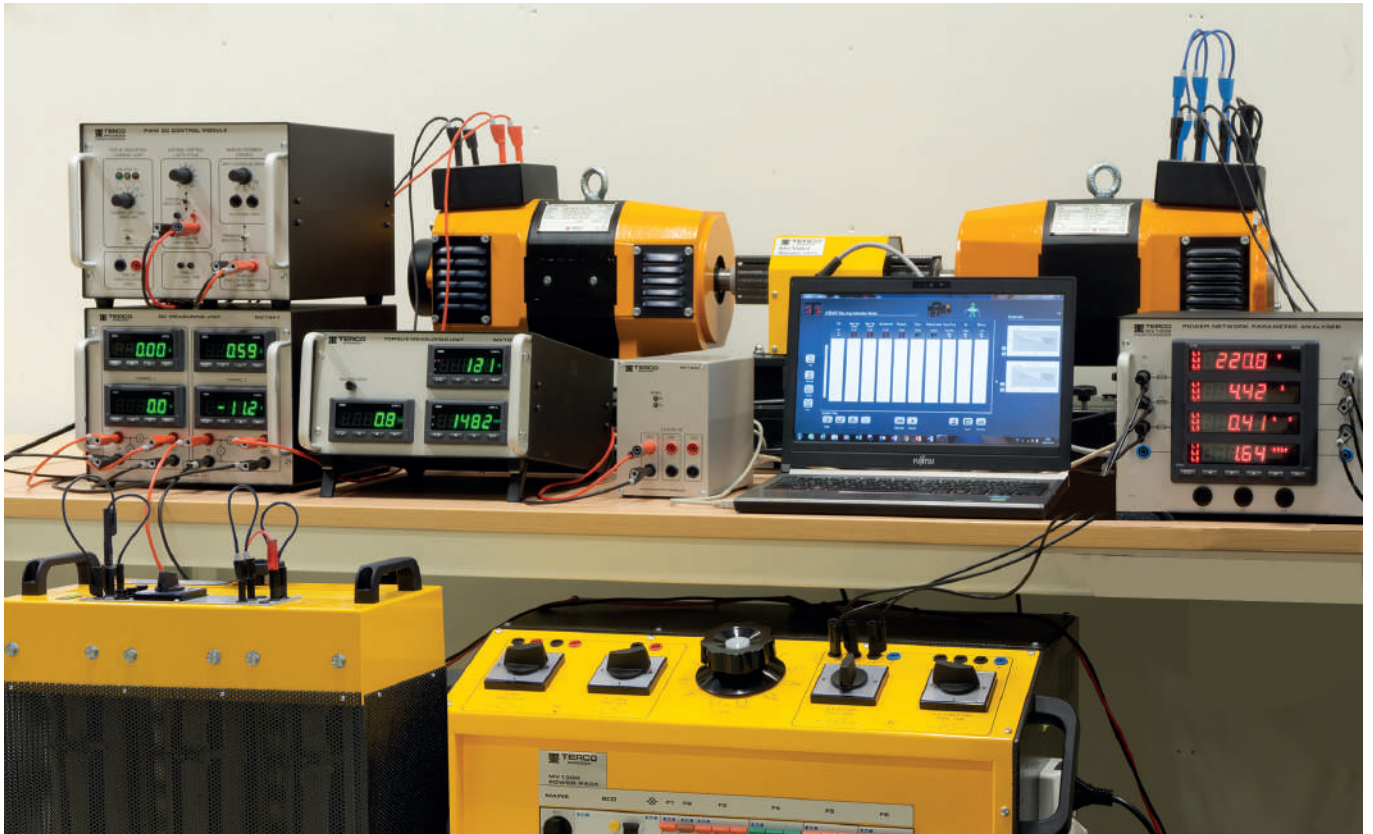

For more than 50 years, Terco has developed and sold electrical machines for technical education. TERCO systems are today installed in hundreds of schools all over the world.

Through consultation, individual needs can be met with a customized package including hardware solutions and relevant study programs.

The test motors and generators have a power output of approximately 1 kW. This size of machines is such that :

- Standard instruments can be used.
- Safety precautions can be observed easily.
- It is possible to interchange the machines without using a crane or hoist.
- They represent typical characteristics for electrical machines.
- Prices are competitive.

Thanks to the top quality and robust construction of Terco products, they are able to withstand rough handling by young, inexperienced students.

With Terco Classic Machines it is possible to produce characteristics which are typical for machines with 6-8 kW ratings, partly because Terco Electrical Machines have a robust construction with a higher than normal iron and copper content.

This makes it possible to overload the machines more before reaching saturation. If you compare the weight of corresponding machines from other manufacturer you will see the difference.

Important Notice - Explanation of Suffix at page 2

Small machines 1 kW with characteristics as large



MV1028 DC Machine (Motor and Brake Machine)

Complete with interpoles. This machine is used in test machine sets such as motors or generators, mounted on a 10 mm thick anodized Aluminum plate to be placed on the machine bed MV 1004.

General Data	MV1028-225	MV1028-226
Generator	2.2 kW 1500 rpm	2.2 kW 1800 rpm
Motor	2.0 kW 1400 rpm	2.0 kW 1700 rpm
Excitation	220 V 0.8 A	220 V 0.8 A
Armature	220 V 12 A	220 V 12 A
Moment of inertia	J = 0.012 kgm ²	MV1028-226 and are
Dimensions	465 x 310 x 310 mm	designed for tests on
	Shaft height 162 mm	60 Hz networks.
Weight	50 kg	

MV1008-225 and -405 are designed for tests on 50 Hz networks. MV1008-226 and -406 are designed for tests on 60 Hz networks. DC machine MV1036-226 is designed for tests on electrical machines with 60 Hz ratings.



MV1006 DC-Machine

The machine has a shunt and a series winding and can be connected as shunt motor, series motor, compound motor, shunt generator, series generator or compound generator. MV1006 has also commutating poles (interpoles) which improve the characteristics of the machine.



General Data	MV1006-225	MV1006-226
Generator	1.2 kW 1400 rpm	1.2 kW 1700 rpm
Shunt motor	1.0 kW 1400 rpm	1.0 kW 1700 rpm
Series motor	1.0 kW 1150 rpm	1.0 kW 1400 rpm
Rotor	220 V 5.5 A	220 V 5.5 A
Excitation	220 V 0.55 A	220 V 0.55 A
	The series winding has an extra terminal at 2/3 of the winding.	
Moment of inertia	J = 0.012 kgm ² (approx.)	
Dimensions	465 x 300 x 310 mm, Shaft height 162 mm	
Weight	45 kg	

MV1006-1 Double Shaft DC-Machine

MV1008-225 and -405 are designed for tests on 50 Hz networks. MV1008-226 and -406 are designed for tests on 60 Hz networks. DC machine MV1036-226 is designed for tests on electrical machines with 60 Hz ratings.

MV1007-405 Induction Motor Slip Ring

The machine is a 3-phase slip-ring asynchronous motor with means to connect a rotor starter to be used for starting. Terminals on anodized front panel with symbols and electrical data.



General Data	50 Hz	60 Hz
Power	1.1 kW,	1.1 kW,
Speed	1440 rpm, 50 Hz	1680 rpm, 60 Hz
Star connection	380-415 V, 3.2 A	380-415 V, 3.2 A
Delta connection	220-240 V, 5.5 A	220-240 V, 5.5 V
Secondary	260 V, 3.0 A	260 V, 3.0 A
Moment of inertia	J = 0.012 kgm ² (approx.)	
Dimensions	465 x 300 x 310 mm, Shaft height 162 mm	
Weight :	42 kg	

MV1007-695 Induction Motor Slip Ring

As MV1007-405 but for 380-415 V 3-phase, Delta, 50-60 Hz



MV1008 Synchronous Machine

The machine has a DC excited cylindrical rotor, operating on voltages up to 220 V DC (maximum excitation).

General Data	MV1008-235	MV1008-236 (60 Hz)
Synch. Gen.	1.2 kVA x 0.8	1.2 kVA x 0.8
Synch. Motor	1.0 kW 1500 rpm	1.0 kW 1800 rpm
Star conn.	220-240 V 3.5 A	220-240 V 3.5 A
Delta conn.	127-140 V 6.1 A	127-140 V 6.1 A
Excitation DC	220 V 1.4 A	220 V 1.4 A
	MV1008-405	MV1008-406 (60 Hz)
Synch. Gen.	1.2 kVA x 0.8	1.2 kVA x 0.8
Synch. Motor	1.0 kW 1500 rpm	1.0 kW 1800 rpm
Star conn.	380-415 V 2.0 A	380-415 V 2.0 A
Delta conn.	220-240 V 3.5 A	220-240 V 3.5 A
Excitation DC	220 V 1.4 A	220 V 1.4 A
Moment of inertia	J = 0.012 kgm ² (approx.)	
Dimensions	465 x 300 x 310 mm, Shaft height 162 mm	
Weight	39 kg	

MV1008-235 and -405 are designed for tests on 50 Hz networks.
MV1008-236 and -406 are designed for tests on 60 Hz networks.



MV1009-405 Induction Motor Squirrel Cage

General Data	50 Hz	60 Hz
4 pole machine	1.1 kW 1400 rpm	1.1 kW 1700 rpm
Star (Y)	380-415 V, 2.4 A	380-415 V, 2.4 A
Delta (D)	220-240 V, 4.1 A	220-240 V, 4.1 A
Moment of inertia	J = 0.0023 kgm ² (approx.)	
Dimensions	355 x 300 x 310 mm Shaft height 162 mm	
Weight	19 kg	



MV1009-695 Induction Motor Squirrel Cage

As MV1009-405 but for 380-415 V 3-phase Delta. With this machine it is possible to do star/delta starts for 380-415 V lab voltage.

MV1009-385 Induction Motor Squirrel Cage

A 4-pole motor of 1.5 kW. Same design and electrical voltages as MV1009-405.

MV1009-405-1 Double Shaft Induction Motor Squirrel Cage

A 4-pole motor of 1.5 kW. Same design and electrical voltages as MV1009-405.

With Terco Classic Machines it is possible to produce characteristics which are typical for machines with 6-8 kW ratings, partly because Terco Electrical Machines have a robust construction with a higher than normal iron and copper content.

This makes it possible to overload the machines more before reaching saturation. If you compare the weight of corresponding machines from other manufacturer you will see the difference.

MV1054 Digital Torque-, Speed- and Shaft Power Meter

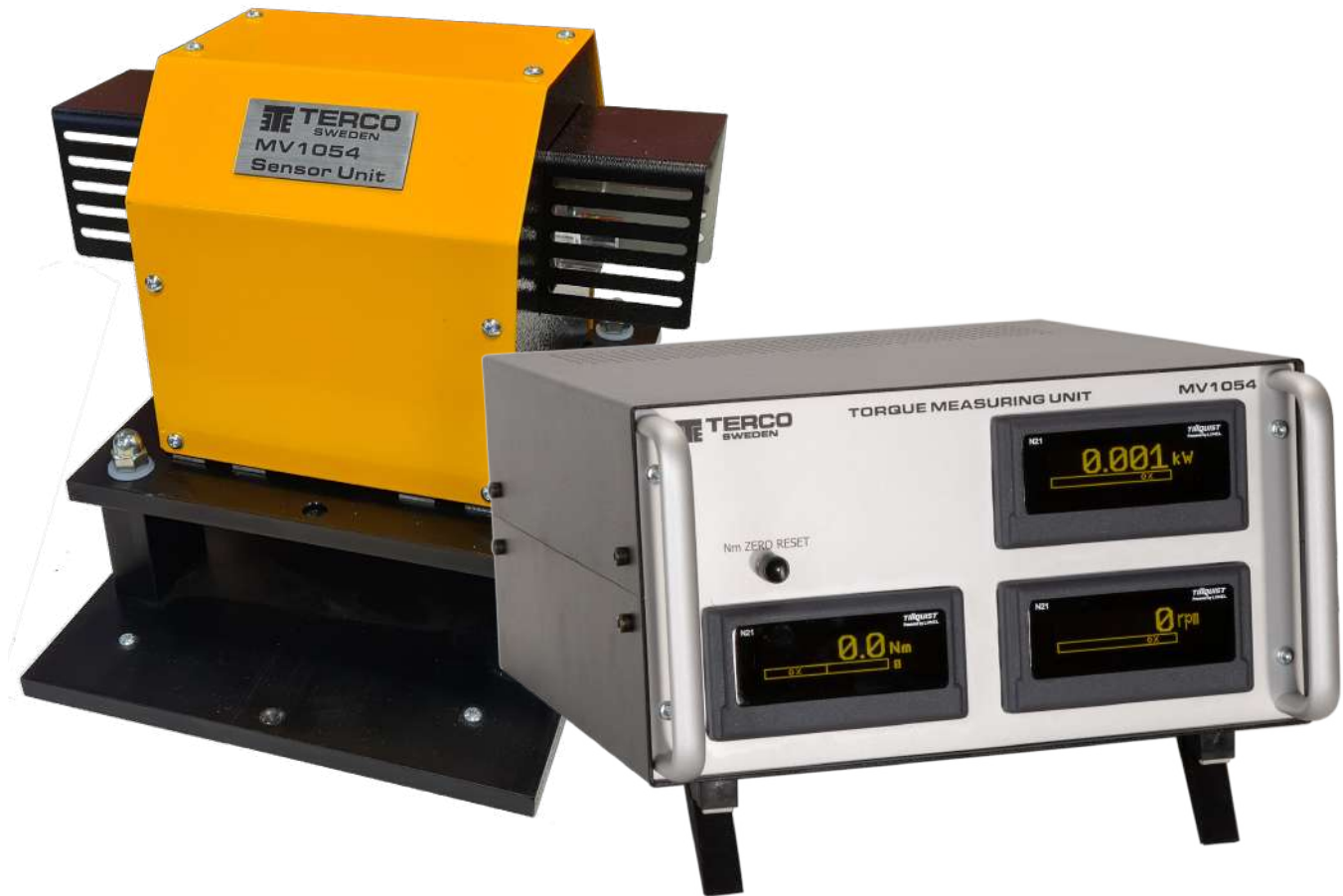

MV1054 is a modern torque meter based on the latest sensor technology. It comprises a magnetically based contactless torque sensor together with data acquisition and a display unit for torque, speed and shaft power. The sensor unit consists of a magnetically encoded torsion shaft with a magnetically based contactless sensor, together with a data acquisition unit with 15 bit resolution.

Torque measurement is performed/presented within the range -17.50Nm - +17.50Nm with exceptionally high accuracy including stand still torque as it is possible to lock the shaft with a specially attached bar.

Speed measurement is performed/presented within the range -3000- +3000rpm and the shaft power is calculated and presented within the range -5.50kW- +5.50kW.

Technical Specifications

Nominal torque	+/-17.50Nm
Max. mechanical torque	25Nm
Nominal shaft power	+/-5.50kW
Nominal speed	0 - 3000rpm
Data acquisition protocol	Modbus RTU 8N2
Baud Rate	9600kB/19200kB
Power supply	220-240VAC
1-phase, 50-60Hz	

Sensor Unit	Dimensions	200x190x146mm
	Weight	5kg
Display Unit	Dimensions	340x250x150mm
	Weight	5kg

Terco reserves the right to make changes in the design and modifications or improvements of the products at any time without incurring any obligations

Measuring, Control and Data Acquisition for PC



Via the MV2658 PWM DC Control Module and the DC machine on the left, electric energy can be supplied or received for braking depending on which electric machine is being tested (right machine). Different lab setups can be selected via PC. All electrical and mechanical parameters can be logged for presentation in the PC.

The system contains of an combination of Measuring units, Control Units, Data Interface Module and Data acquisition software, enabling the user to observe, control, record and investigate relevant electrical data.

The software is designed to work with Terco Modbus instruments but may be set up to communicate with many Modbus devices.

Pre-configured experiment setups are included but the experiment presentation window is fully customizable, allowing the user to select available hardware, define data columns and set up graph parameters such as data sources and titles.

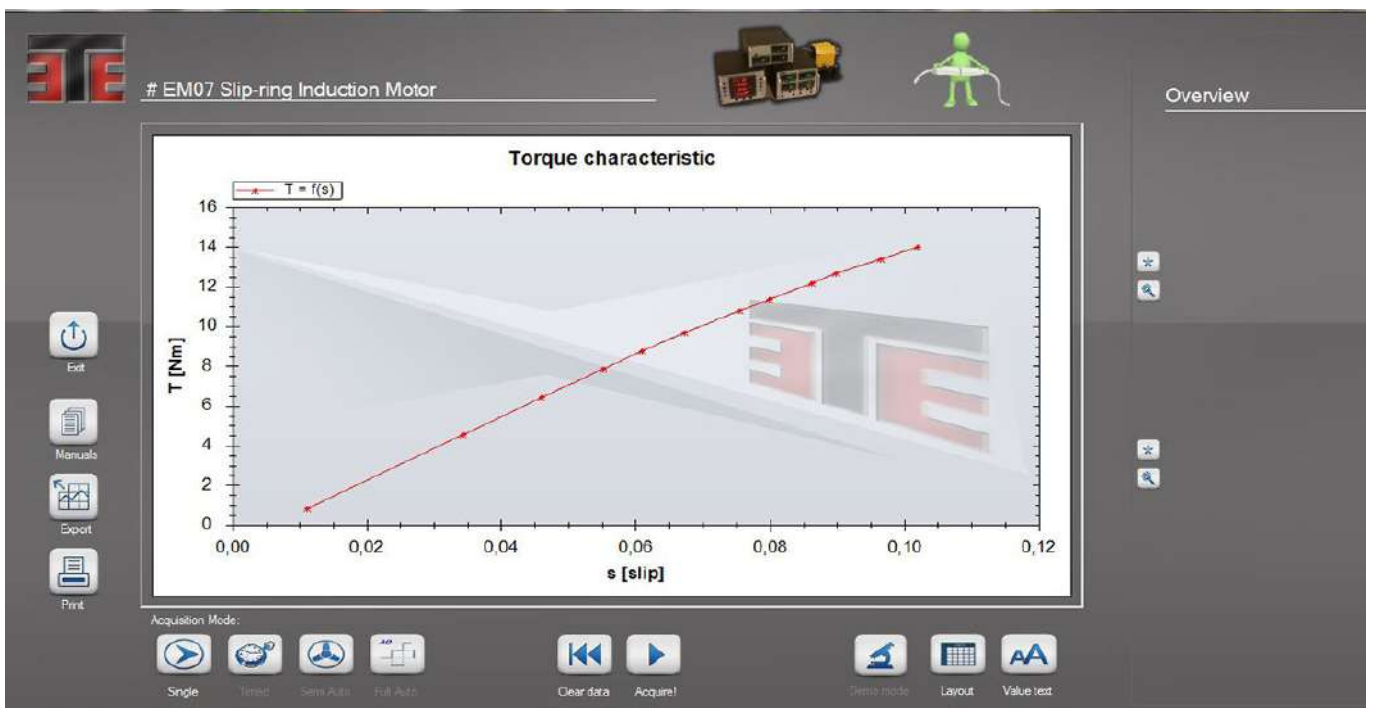

Graph presentation on PC

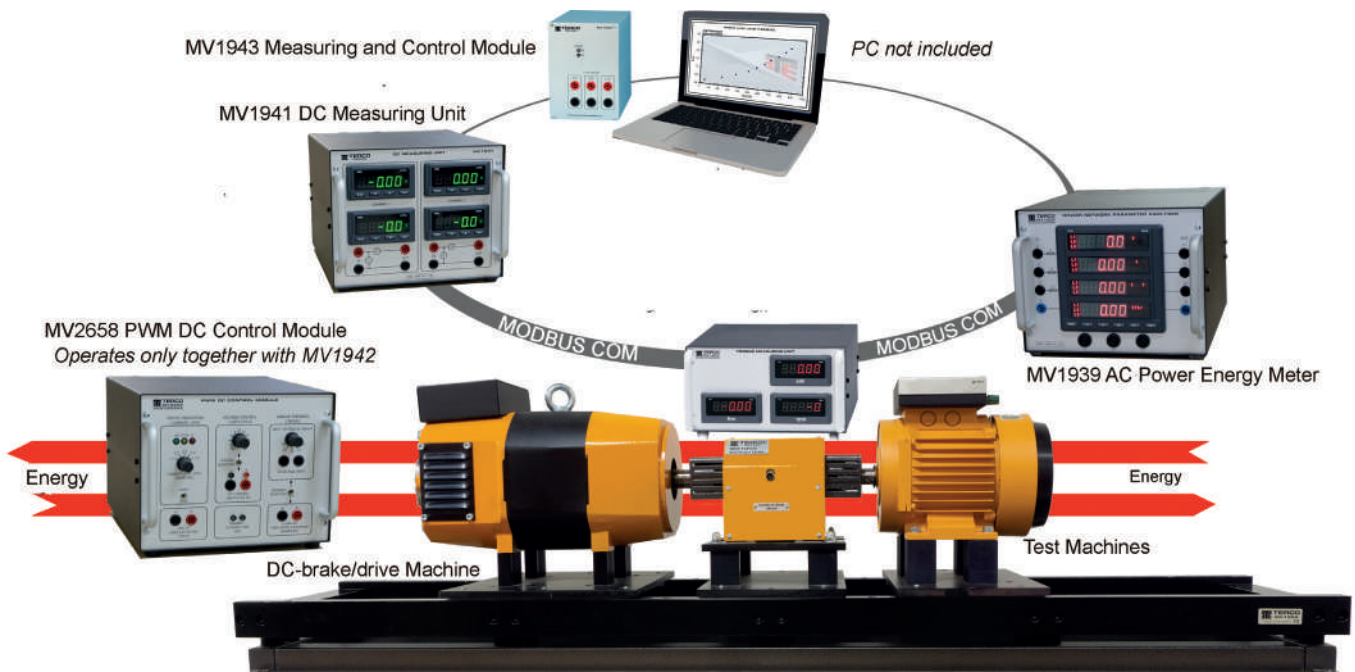

MV1943 Measuring and Control Module

The MV1943 Measuring and Control Module integrates the communication interface functionality of a USB to RS-485 adapter, with a 3-channel Modbus controlled 0-10V DC source in one compact unit.

Coupled with the MV2658 PWM Control unit, the MV1943 provides both communication between Terco measuring units and a PC, as well as simultaneous motor control. The 3-channel analog output is controlled via PC using the Terco Data Acquisition Software and enables additional features such as fully automatic data acquisition.

Voltage output:

Channels	3
Channel output	0-10 V
Resolution	12 bit (2.5 mV)
Isolation	1500 Vac, Field to Logic
Control system	Terco MV2609 Control and Data Acquisition Software
Dimensions	105mm x 147mm x 167mm
Weight	300g



MV1942 Data Interface Module

Technical Specifications

Communication:

Interface	USB plug and play
Operating system	7/Vista/XP
Field interface	RS485
Maximum devices	32 devices
Power source	USB port
Power supply	220-240VAC, 50/60Hz

Communication:

Interface	USB plug and play
Operating system	7/Vista/XP
Field interface	RS485
Maximum devices	32 devices
Power source	USB port

MV2609 Control and Data Acquisition Software



Acquisition functions

Data is read into the PC via Modbus to USB link and presented in real-time in both tabular and graph form.

Data may be acquired using one of 4 possible acquisition modes: Single, Timed, Semi-Automatic and Full Automatic. The saved data can then be exported in Excel format for further investigation.

Pre-configured experiment setups

are included but the experiment presentation window is fully customizable, allowing the user to select available hardware, define data columns and set up graph parameters such as data sources and titles.

The software is designed to work with Terco Modbus instruments but may be set up to communicate with many Modbus devices.



MV2658 PWM DC Control Module



Technical Specifications

- PWM (16kHz) Based Excitation Voltage 0-260VDC.
- Selectable Current Limit Levels (front panel switch): 1.7ADC, 2.5ADC, 3.5ADC, 5.0ADC, 7.5ADC.
- Fixed Excitation Output 200VDC (for DC Drive application).
- PWM Controlled Excitation on the front panel control
- 0-100% Duty Cycle) or from the control input
- fully isolated, 0-10VDC = 0-100% Duty Cycle.

The control input can be used for instance in PC based control together with Terco DAQ software. (Optional analogue output interface unit necessary).

- Control Methods selectable between PWM Controlled Excitation Voltage Feedback and External Analog Voltage Feedback.
- Power Supply 220-240VAC, 50/60Hz

- Dimensions: 255 x 195 x 330mm
- Weight: 8kg (approximately)

MV2658 is an indispensable equipment in the electrical machines laboratory as it can be used in several different types of applications.

It can be used as a DC-Machine Drive in the range up to 1.2kW, a Generator Field Controller (VAr controller), or a Machine Brake Controller suitable with Terco equipment in the range up to 3.3kW

Additional Machines



MV1015-405 Reluctance Motor

A reluctance motor starts as an induction motor, but operates normally as synchronous motor. A three-phase reluctance motor is self-starting when started as an induction motor. After starting, in order to pull it into step and then to run it as a synchronous motor, the reluctance motor has low rotor resistance. Some rotor teeth are removed to form a typical construction of a four-pole rotor.

General Data	50 Hz	60 Hz
Power	0.9 kW	0.9 kW
Speed	1500 rpm	1800 rpm
Delta Connection	220-240 V, 6.4 A	220-240 V, 6.4 A
Dimensions	360 x 300 x 310 mm	
	Shaft height 162 mm	
Weight	25 kg	

MV1015-695 Reluctance Motor

Same as MV 1015-235 but for 380-415 V, 3-phase, Delta.



MV1017-235 Induction Dahlander Motor

The winding of the Dahlander motor is arranged in a way, that by connecting in different formations 2 speeds are available. Switching can be performed using a cam switch or using contactors.

General Data	50 Hz	60 Hz
Power	0.9 / 1.3 kW	0.9 / 1.3 kW
Speed	1400 / 2800 rpm	1680 / 3310 rpm
Voltage	D / YY 220-240 V	D / YY 220-240 V
	3-phase	3-phase
Current	5.4 / 4.7 A	5.4 / 4.7 A
Dimensions	355 x 300 x 340 mm	
	Shaft height 162 mm	
Weight	17 kg	

MV1017-405 Induction Dahlander Motor

As MV 1017-235 but for 380-415 V 3-phase



MV1505 Dahlander Switch

for Dahlander motor MV 1017, 16 A, 400 V, in metal case. Front panel showing symbols and technical data.

Marking of terminals	input R, S, T
	output 1 Ua, Va, Wa
	output 2 Ub, Vb, Wb
Dimensions	95 x 200 x 80 mm
Weight	1 kg

Important Notice - Explanation of Suffix at page 2



MV1018 Universal Motor

This is a commonly used motor in domestic appliances. It can be run on DC or AC 1-phase. The rotor is connected in series with the field winding and supplied via the commutator and brushes.

General Data

Power	1 kW DC at 2600 rpm, 0.4 kW AC
Speed	3000 rpm at 50 Hz 3600 rpm at 60 Hz
Voltage	220-240 V AC / DC
Current	8 A AC, 7 A DC
Dimensions	465 x 300 x 310 mm Shaft height 162 mm
Weight	39 kg



MV1027 Synchronous Machine

The machine has a DC excited rotor with salient poles, operating on voltages up to 220 V DC (maximum excitation).

The advantages rising from this type of machine are measurements and characteristics corresponding to those of larger machines and the excitation voltage is readily available in most laboratories. An additional damping winding will counteract oscillations and also facilitate return to synchronism if the rotor falls out of phase.

The damping winding also allows the motor to be started as an asynchronous motor before energizing the field. Suitable excitation rheostat : MV1905.

General Data

Synch. Gen.	MV1027-235 1.2 kVA x 0.8
Synch. Motor	1.0 kW 1500 rpm
Star conn.	220-240 V 3.5 A
Delta conn.	127-140 V 6.1 A
Excitation DC	220 V 1.4 A
Moment of inertia	J = 0.012 kgm ² (approx.)
Dimensions	465 x 300 x 310 mm, Shaft height 162 m
Weight	39 kg

MV1027-236

1.2 kVA x 0.8
1.0 kW 1800 rpm
220-240 V 3.5 A
127-140 V 6.1 A
220 V 1.4 A

MV1027-405

1.2 kVA x 0.8
1.0 kW 1500 rpm
380-415 V 2.0 A
220-240 V 3.5 A
220 V 1.4 A

MV1027-406

1.2 kVA x 0.8
1.0 kW 1800 rpm
380-415 V 2.0 A
220-240 V 3.5 A
220 V 1.4 A

MV1027-235 and -405 are designed for tests on 50 Hz networks.
MV1027-236 and -406 are designed for tests on 60 Hz networks.

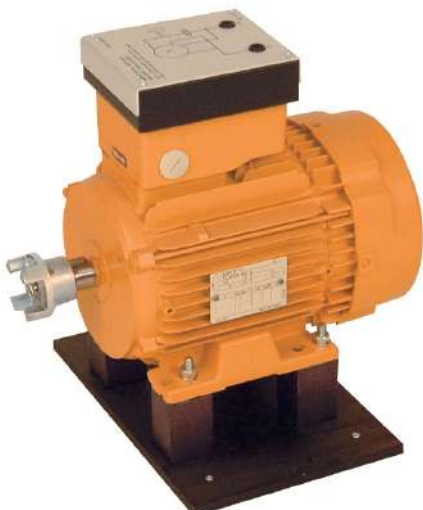

MV1020 Induction Motor Capacitor Start

The capacitor assisted starting winding is disconnected from the circuit when the motor has built up speed, by means of a relay.

General Data

	50 Hz	60 Hz
Power	0.75 kW	0.75 kW
Speed	1425 rpm	1710 rpm
Voltage	220-240 V 1-phase	220-240 V 1-phase
Current	6.8 A	6.8 A
Capacitors	310 uF	310 uF
Dimensions	350 x 300 x 350 mm Shaft height 162 mm	
Weight	24 kg	



MV1037 Induction Motor Cap. Start and Run

To obtain a higher starting torque, the starting winding has a capacitor connected in series. Continuous rating of start winding allows the circuit to remain the same during starting and running.

General Data	50 Hz	60 Hz
Power	0.75 kW	0.75 kW
Speed	1430 rpm	1715 rpm
Voltage	220-240 V	220-240 V
	1-phase	1-phase
Current	5.4 A	5.4 A
Capacitors	25uF & 100 uF	25 uF & 100 uF
Dimensions	320 x 300 x 350 mm Shaft height 162 mm	
Weight	20 kg	



MV1030-235 Induction Motor 2 Speed 2 Windings

This motor unlike MV 1017 which has only one set of windings, has 2 separate sets of windings for high and low speed.

General Data	50 Hz	60 Hz
Power	0.8 / 1.0 kW	0.8 / 1.0kW
Speed	930 / 1440 rpm	1120 / 1730 rpm
Voltage	220-240 V	220-240 V
	3-phase	3-phase
Current	4.7 / 6.0 A	4.7 / 6.0 A
Dimensions	450 x 300 x 340 mm Shaft height 162 mm	
Weight	24 kg	

MV1030-405 Induction Motor 2 Speed 2 Windings

As MV1030-235 but for 380-415 V, 3-phase.



MV1031 Induction Motor Thermistor Protected

This squirrel cage motor has a thermistor built into the windings for temperature control of the motor. Thermal relay MV 1032 is used in conjunction with this motor.

General Data	50 Hz	60 Hz
Power	1.1 kW	1.1 kW
Speed	1400 rpm	1700 rpm
Voltage	380-415/220-240 V	380-415/220-240 V
	3-phase	3-phase
Current	3.0 / 5.2 A	3.0 / 5.2 A
Dimensions	340 x 300 x 310 mm, Shaft height 162 mm	
Weight	22 kg	



MV1032 Thermal Relay

This is a control unit against overheating of motor MV1031. Most electrical machines withstand today 140°C or more. However, it takes a long time to reach this temperature and the lab time is limited in the laboratory. Therefore we have chosen a cut off temperature at 60°C for the experiments.

Dimensions 130 x 245 x 95 mm
Weight 1 kg



MV1047 Asynchronous Motor, 3-Phase Demonstration Set

The components of a type MT 63 induction motor are mounted on a wooden board. Only a screwdriver is needed to assemble the motor, and to permit repeated assembly and dismantling.

It is recommended to use 40V, 3-phase supply for testing the operation of the motor.

Dimensions 480 x 400 x 150 mm
Weight 7 kg



MV1010 Flywheel

The flywheel is stably journaled in 2 spherical bearings and secured to an Aluminum foundation. This ensures correct shaft height and lateral alignment.

The flywheel is dynamically balanced and has a protective casing with 2 couplings. It is used in retardation tests for determining total friction losses, iron losses and short circuit losses at different excitation levels.

MV1010 is also suitable to use for tests with heavy load start.

Moment of inertia $J = 0.406 \text{ kgm}^2$
Dimensions 400 x 300 x 300 mm
Weight 56 kg



On the back of the MV1905 is placed a cooling fan

MV1905 Shunt Regulator

Used for field regulation of DC-machines MV1006, MV1028, MV1034 and for synchronous machines MV1008 and MV1027.

General Data

Power Supply 230V AC
Potentiometer-connected 440 ohms
Supply voltage 220 V DC
Max current 2 A
Dimensions 215 x 190 x 230 mm
Weight 3 kg



MV1903 Synchronizing Device

The equipment includes 1 zero voltmeter, 1 circuit breaker, 3 signal lamps and terminal bolts.

General Data	MV1903-235	MV1903-405
Zero Voltmeter	2 x 140 V	2 x 220 V
Circuit Breaker	16 A 500 V	16 A 500 V
Synch. Lamps	130 V with resistor	220 V with resistor
Supply Voltage	220-240/127-140V	380-415/220-240 V
	50-60 Hz	50-60 Hz
Dimensions	315 x 240 x 90 mm	
Weight	3 kg	
Other voltages can be supplied on request.		



MV1004 Machine Bed

This strong, stable machine bed of anodized aluminum bars has rubber dampers on the underside to prevent transmission of vibration to the base. Clamps for mounting torque meter and machines are included

Dimensions	1500 x 300 x 65 mm
Weight	15 kg



MV1004 Machine Bed used with motors and generators.

MV1500 Load Switch

Three-pole,	16 A, 250 V- DC/440 V-AC,
Dimensions	95 x 200 x 80 mm
Weight	1 kg

MV1502 Reversing Switch

Suitable for 3-phase machine,	16 A, 500 V
Dimensions	95 x 200 x 80 mm
Weight	1 kg

MV1503 Star / Delta Switch

Suitable for 3-phase machine,	16 A, 500 V
Dimensions	95 x 200 x 80 mm
Weight	1 kg



Sectioned Motors

Not for connecting to the main and operation!

The machines are sectioned about 90° allowing all the main components to be demonstrated clearly and in an educational way. Please note : It is not possible to do any practical experiments with the machines.



MV1006-C

MV1006-C DC Machine

This machine is cut-away to show commutator, brushes, rotor, stator, windings, ball-bearings.

Rated power 1.0 kW
 Dimensions 465 x 300 x 310 mm
 Shaft height 162 mm
 Weight 40 kg



MV1008

MV1008-C Synchronous Machine

This machine is cut-away to show slip-rings, brushes, rotor, stator, windings, poles, ball-bearings etc.

Rated power 1.0 kW
 Dimensions 465 x 300 x 310 mm
 Shaft height 162 mm
 Weight 35 kg



MV1007

MV1007-C Induction Motor Slip-Ring

This motor is cut-away to show slip-rings, brushes, rotor, stator, windings, poles, fan, ball-bearings, etc.

Rated power 1.1 kW
 Dimensions 440 x 300 x 350 mm
 Shaft height 162 mm
 Weight 37 kg



MV1009

MV1009-C Induction Motor Squirrel Cage

This motor is cut-away to show rotor, stator, windings, poles, fan, ball-bearings, etc.

Rated power 1.1 kW
 Dimensions 355 x 300 x 310 mm
 Shaft height 162 mm
 Weight 15 kg

Electric Torque Meter System, Analogue Dial incl. DC-brake / DC-drive Machine



A DC pendulum machine is freely suspended on plumb-er blocks and placed on an Aluminum foundation plate. The front panel is fitted with the necessary meters, controls and connection terminals. The torque is read on an analogue dial. The DC-machine has interpoles.

This analogue torque measuring system is very peda-gogical and easy to handle. It is a reliable product which has been sold to many technical schools worldwide.

The picture shows MV1036 mounted on the machine bed MV1004 together with the tachometer generator MV1025 and the DC- test machine MV1006

MV1036-225 Electric Torque Meter System

Speed	0-4000 rpm
Ammeter	0-1 A (Field)
Ammeter	0-15 A (Arm.)
Shunt Control	Potentiometer
Torque	Grad. 0 – ± 25 Nm
Scale diam.	390 mm
Termination	4 mm terminals
Generator	2.2 kW 1500 rpm
Motor	2.0 kW 1400 rpm
Excitation	220 V 0.8 A
Armature	220 V 12 A
Dimensions	600 x 540 x 960 mm
Weight	90 kg

DC Machine MV1036-225 is designed for tests on electrical machines with 50 Hz ratings but can be used for 60Hz (higher speed but less torque)

MV1026-225 Electric Torque Meter System

Same as MV1036-225, but the drive motor has a double ended shaft, enabling to couple two machines at the same time for experiments and studying 4Q drives with one AC- and one DC drive/motor, Ward-Leonard system, cascade, etc. For central mounting on the machine bed. Designed for tests on electrical machines with 50 Hz ratings.

MV1036-226 Electric Torque Meter System

As MV1036-225 but following ratings.	
Generator	2.2 kW 1800 rpm
Motor	2.0 kW 1700 rpm
Excitation	220 V 0.8 A
Armature	220 V 12 A
Weight	90 kg
Dim:	600 x 540 x 960 mm

DC machine MV1036-226 is designed for tests on electrical machines with 60 Hz ratings.

MV1026-226 Electric Torque Meter System

Same as MV1036-226 except that the drive motor has a double ended drive shaft, making it possible to couple two machines at the same time for experiments and studying 4Q drives with one AC- and one DC drive/ motor, Ward-Leonard system, cascade, etc. For central mounting on the machine bed. Designed for tests on electrical machines with 60 Hz ratings.



ORDER INFORMATION ELECTRICAL MACHINES LABORATORY

Product no	Description	Pc	Page
Electrical Machines Laboratory. Experiment Voltage 3 x 400V or 3 x 230V (MV1300 is changeable)			
MV1028-225	DC-Machine, 2.2 kW complete with interpoles 220V	1	48
MV1006-225	DC-Machine 1 kW 220 V 50 Hz	1	48
MV1007-405	Induction Motor slip-ring 1.1kW 400/230V 50-60Hz 1.1kW	1	48
MV1008-235	Synchronous Machine, 230 V Y 50 Hz 1.2 kVA x 0.8	1	49
MV1009-405	Induction Motor Squirrel Cage, 400/230V 50-60 Hz 1,1 kW	1	49
MV1054	Digital Torque-, Speed- and Shaft Power Meter	1	50
MV1004	Machine Bed	1	58
MV2636	Starter AC- and DC-Motors, Classic	1	182
MV1300-405	Power Pack 3-ph, supply 400 V, out 230 V	1	177
MV1417	Terminal Board	1	195
MV1500	Load Switch, 3-pole 16A	1	58
MV1502	Reversing Switch	1	58
MV1503	Star-Delta Starter for 3-ph Machines	1	58
MV1905	Shunt Regulator	2	57
MV1903-235	Synchronizing Device 220-240 V 50-60 Hz	1	58
MV1003	Mobile Test Bench	1	197
MV1100-235	Load Resistor 3-ph 3.3 kW	1	181
MV1101	Load Reactor, 3-phase, 2.5 kVAr	1	181
MV1102	Load Capacitor, three-phase 2.8 kVAr	1	181
MV1830-HF	Flex Set, 100 Safety Leads, Safety Plugs	1	198
MV1904	Flex Stand	1	199
Measuring and Data Acquisition			
MV1939	AC Power Energy Meter	1	187
MV1941	DC Measuring Unit	1	187
MV1943	Measuring and Control Module	1	52,28
MV2609	Control and Data Acquisition Software	1	53,186
Phase Cop 2	Phase Sequence Indicator	1	189
MV2658	MOSFET - PWM Module	1	53
Optional - Additional Machines and Torque Measuring,			
See page 56-60			
Electrical Torque Meter System, Analogue Dial. incl. DC-brake / DC-Drive Machine			
See page 61			

Ref. 200

Terco reserves the right to make changes in the design and modifications or improvements of the products at any time without incurring any obligations

Each delivery is packed according to export standard with correct marking and documentation



Training at the customer site or at TERCO Head Office in Stockholm, Sweden

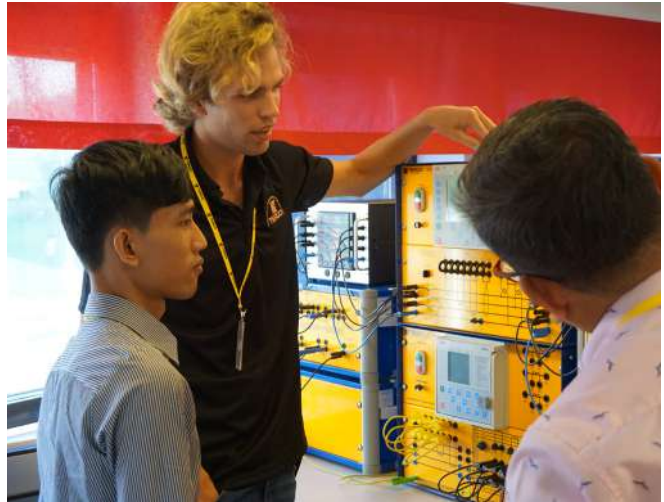

MV4207-1 DC-Motor Drive

Single-phase 4-Quadrant Rectifier, Three-Phase supply

Covers the latest development in DC-motor operation with analogue control. The equipment is designed to work according to different industrial environments. The drive has signal in- and outputs for connections to slave and/or master drives.

To cover a wider range of machines regarding voltage and speed the primary supply is taken from a standard 3-phase outlet which will supply the inverter bridges by 2-phase 400 V.

The design will enhance the possibilities of learning the theory and practice of understanding the operation of 4Q-drives for both single drives and the basic understanding of three bridges and their commutation.

The 4-Q-DC-Drive can be used in the conception of speed/torque control versus electro-machine theory. When braking, the energy is transferred directly to the supplying network by operating in all four quadrants.

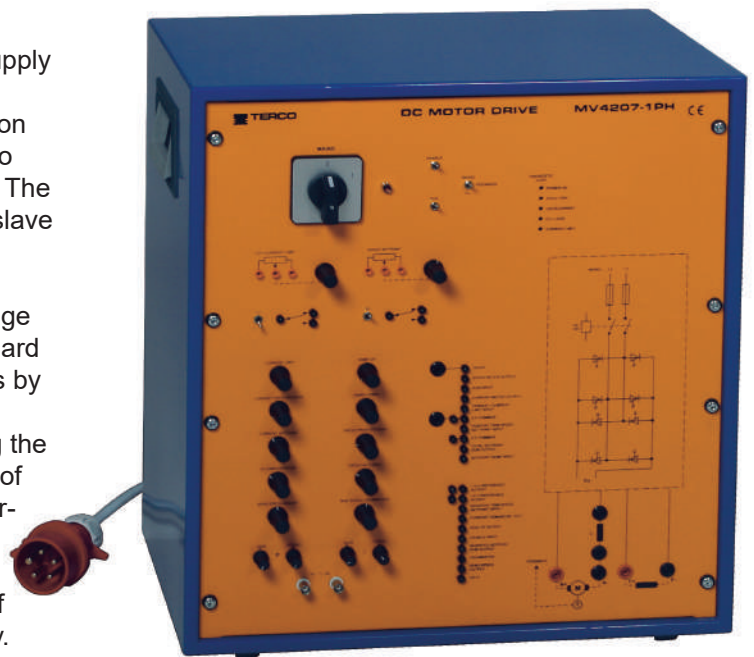

Technical Specification

Input voltage:	3-phase 3 x 400 V + N + PE, 50-60 Hz
Input max current:	16 A, rotor inductance is included
Output voltage:	0-250 V DC
Output current:	0 - 12 A (max 16 A)
Nom. output power:	2 kW
Design:	Tutorial where the 4Q industrial/ professional aspects are enhanced
Control:	Manually operated Digital / Analogue
Front control parameters:	12
Feedback:	DC-tacho or armature voltage
Built-in unit for immediate:	U+I+P signals, isolated, including MUX for oscilloscope.
Built-in protections and contactor relays	
Dimensions	520 x 450 x 280 mm
Weight	23 kg

Standard Settings

12 Parameters are set manually:

Typically: Speed, Max Speed, Acc ram, Flux, Ret ramp, Ilim, Current/Speed proportional, Current demand in/out, etc.

Floating switches and potentiometers are used to study step response and stability. The results of the dynamic response regarding voltage, current and immediate power can be studied fully isolated on a standard oscilloscope via the built in isolation amplifier and multiplexer.

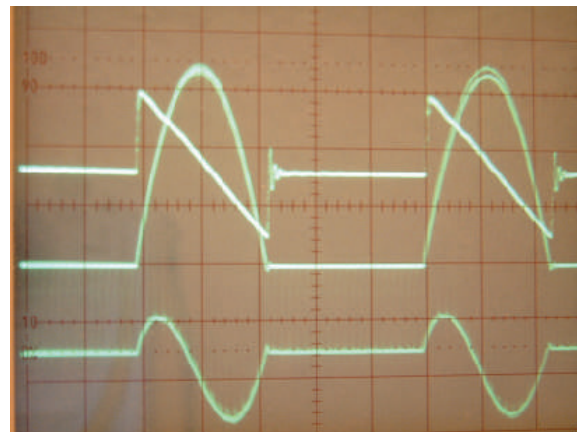

Manuals

Consist of a theory section and an exercise section. The theory part explains for example general theory of the conditions for torque developed in an arbitrary machine, while the exercise section contains theory sections that are directly connected to the different experiments. The Manual consists of a complete binder together with an additional section, which will explain the UIP-unit (Voltage/Current/Power – unit) together with oscilloscope snap-shots showing different operation modes of the rectifier.



MV4207-3 DC-Motor Drive

Three-phase 4-Quadrant Rectifier, Three-Phase supply covers the latest development in DC-motor PC-controlled operation with 6 pulse 4Q rectifiers. The equipment is designed to work according to different function principles and it is possible to explain several different types of DC-drives depending on the purpose and industrial environment from traction to paper- and steel mills.

Output current/voltage can be chosen to optimize torque/angular speed or to optimize other parameters by using a PC and the enclosed software. When braking, the energy is transferred directly to the supplying network by operating in all four quadrants. The field rectifier can be programmed manually or from a PC for optimized field control.

The 4Q DC Drive can be used in the conception of speed/torque control versus electro-machine theory. The equipment is also suitable for experiments and tests in industrial applications.

Technical Specification

Input voltage: 3-phase 3 x 400 V + N + PE, 50-60 Hz

Input max current: 16 A

Output voltage: 0 - 400 V DC

Output current: 0 - 12 A (max 16 A)

Nominal output power:

2 kW (max 3 kW)

Design: Tutorial but with the PC-controller industrial / professional aspects enhanced.

Control modes: Manually by front components, Manually by Operator Station, PC by RS 232 + "DELite" + software

Front controls: Manually Digital > 20, Analogue > 4

Configuration: by PC or Operator Station

Self-tuning: by PC or Operator Station

Built-in protections and contactor relays

Dimensions 520 x 450 x 280 mm

Weight: 25 kg

Built-in Instruments and Oscilloscope Functions

The enclosed software will make it possible to configure the internal connections and operating principles by using a standard PC. On the screen it is possible to monitor 3 analogue instruments and edit a number of signals/parameters in parallel, which can be saved and printed. The number of parameters/tags possible to study exceeds 200.

Standard Settings and Advanced Settings

Most parameters are set by default but settings can also be done manually from the front controls.

Typically:

Speed, Max Speed, Acc ram, Flux, Ret ramp, Ilim etc.

Advanced settings, >200 parameters/tags, are performed by Operator Station on the unit, PC nearby the unit, connected to COM1 (COM2).

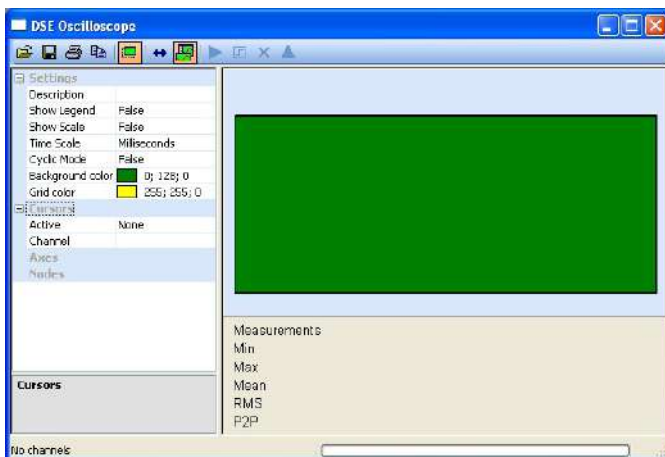
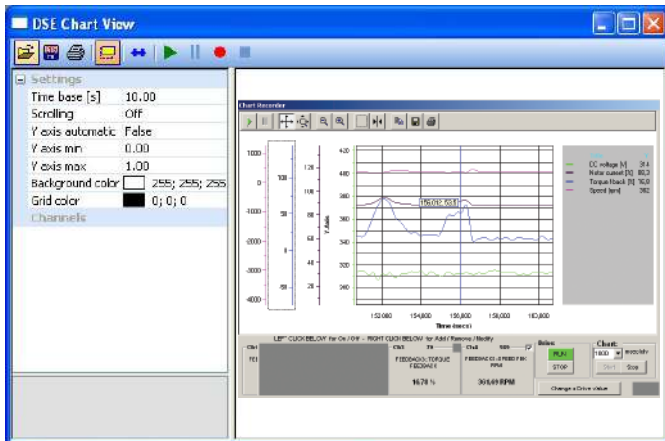

Manuals

Consists of a large quantity of experiments where related theoretical analyzes and explanations are performed in each experiment. Experiments further on covers basic operation and autotuning as well as more advanced operation directly from the drive keypad (operator station) or from PC where signal analysis also are possible by means of the chart recorder and the oscilloscope function.

AC-Drives

MV4206-1 AC-Motor Drive



Three-Phase supply, semi 4-Quadrant Drive frequency converter with MOS FET technique and a fixed intermediate DC-link.

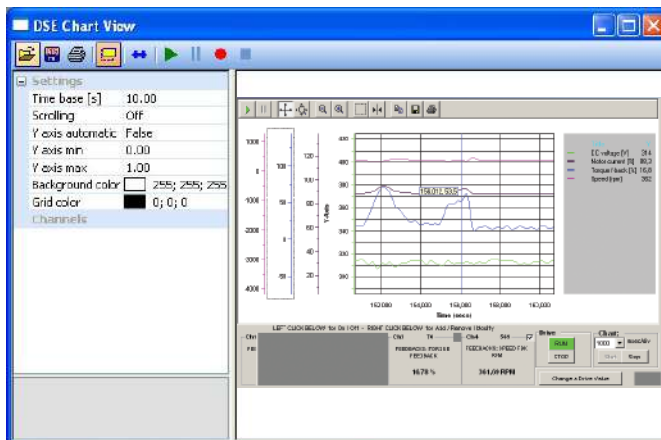

Manuals

consist of a theory section and exercise section together with a software description. The theory part explains for example general theory of the conditions for torque developed in an arbitrary machine, while the exercise section contains theory that are directly connected to the different experiments.

The instruction manual is enclosed as a complete binder together with a corresponding CD.

Covers the latest development in AC-motor operation with frequency converters. The equipment is designed to work according to different function principles and it is possible to explain several different types of frequency converters existing today.

4-Q-Drive: The Frequency Converter can be used in the conception of speed/torque control and electro-machine theory. The equipment is also suitable for experiments and tests in industries i.e. far beyond the area that the experiments show.

When braking, the energy is transferred by the DC-link and a brake chopper to a built-in load resistor. There is also an additional adjustable DC-injection brake.

Technical Specification

Input voltage: 3-phase 3 x 400 V + N + PE, 50-60 Hz

Input current: 16 A max

Output Power: 1.5 kW

Output voltage: 3 x 230 V

Max output current: 7 A

Max output frequency: 100 Hz

Choice of polygon: automatic

Breaking points: automatic

Internal switch frequency: 3 kHz max

Type of modulation: PWM sensorless vector

Intermediate DC-voltage: average value 300 V DC

Inverter bridge: MOSFET

Control voltage: +/- 10V DC analog, 0-24V DC Digital

Dimensions 520 x 450 x 280 mm

Weight 16 kg

Built-in Instruments Functions

The enclosed software will make it possible to configure the internal connections and operating principles by using a standard PC. On the screen it is possible to monitor 3 analogue instruments and scroll a number of signals/parameters in parallel, which can be saved and printed. The number of parameters/tags possible to study exceeds 200.

Standard Settings and Advanced Settings

Most parameters are set by default but settings can also be done manually from the front controls: Typically: Speed, Max Speed, Acc ram, Flux, Ret ramp, I-lim etc. Advanced settings: >200 parameters/tags, are performed by Operator Station on the unit, PC nearby the unit, connected via the comport.



MV2661 AC-Control

The MV2661 is an AC drive primarily designed for speed control of a 3-phase squirrel cage induction motor. Its purpose is to create a sinusoidal (or close to) 3-phase voltage that is connected to the stator of an AC-motor. The AC-drive controls the pulse width and the frequency of the supplied voltage and can therefore keep the motor running at constant speed although the mechanical load applied at the rotor shaft varies. The AC drive includes an autotune-function which automatically identifies the electrical and mechanical parameters of the connected induction motor.

The drive is capable of operating machines up to 1.5kW. It controls the output voltage 0-240V and frequency 0.1-600Hz. The maximum output current is 7.5A and the input current 15.7A (fuse size 15A).

It is mainly designed to operate together with Terco MV-machines, which are sized 1.1 – 1.5kW.

The AC CONTROL MV2661 is furtheron equipped with an internal brake chopper and an internal brake resistor which makes it possible to study short ramp time braking courses.

All essential signals are connected to the front to make it possible not only to run typical experiments verifying the theory but also to make it possible to run the drive out of more advanced industrial aspects.

Technical specifications

Max. Applicable Motor Output	1.5kW
Rated Output Capacity	2.9kVA
Rated Output Current	7.5A
Maximum Output Voltage	3-ph prop. to input V.
Rated Input Current	15.7A (Fused 15A)
Power Supply	220-240VAC, 50/60Hz, 50/60Hz
Voltage Tolerance	+/-10% (180-264V)
Frequency Tolerance	+/-5% (46-63Hz)
Dimensions	340x250x150mm
Weight	6.2kg

ORDER INFORMATION AC- AND DC-MOTOR DRIVES

Additional quotation to Electrical Machines Laboratory

Product no	Description	Pc	Page
DC-Drives			
MV4207-1	DC-Drive	1	63
MV4207-3	DC-Drive, Three-Phase supply	1	64
MV1024	DC-Tachogenerator incl. Cover, trim potentiometer incl.	1	178
MV2658	MOSFET - PWM Module	1	53,135
MV1055	Spacer Shaft	1	
MV1974	Voltmeter, moving coil 0 - +/- 300 V	1	188
AC-Drives			
MV4206-1	AC Motor Drive	1	65
MV2661	AC-Control	1	66

MV1439 Power Factor Control Unit



General

With the Power Factor Control Module (PFC) you can minimise the currents caused by reactive losses of power thereby optimising the transfer of energy between generation and loading.

This is becoming more and more important today when "Saving energy" is vital in a world with focus on pollution and shortage of energy.

Field of application

Inductive or mixed inductive and resistive networks in need of compensation, for example when starting and running induction motors as in industrial applications.

Principles of operation

Depending on the power factor of the loading network a microprocessor will connect groups of capacitors. By measuring phase voltages and current the microprocessor will calculate how many capacitive groups that has to be connected and also in which combinations.

Electrical details

Number of 3-ph groups 6 capacitive
Power factor setting 0 to 0.7

MV1439-235 nominal voltage 3 x 230V, 50-60 Hz
MV1439-405 nominal voltage 3 x 400V, 50-60 Hz

Nominal power	0 – 2 kVAr capacitive
PF-Controller	Automatic or manual Adjustable delay times, switching sequences and strategies.

Monitoring and Measurement on the controller:

Voltage, Current and Power factor

Switching modes: Linear and circular

Indication lamps: Indication lamps for the capacitor groups which are connected

Physical design

The Power Factor Control Unit is housed in a sturdy apparatus box with a clear mimic diagram explaining how to connect the supplying net from the left to the right side where the network in need for power factor compensation is connected.

Readings, parameters and sub parameters are indicated on the front of the controller. Other settings and programming than the defaults are simply performed from the keyboard and displayed on the controller front.

General data:

Power supply:	1-ph 220 - 240 V, 50 - 60 Hz
Dimension:	510 x 570 x 280 mm
Weight	24 kg

Typical Experiments with Terco PFC:

- The concept of active power, apparent power and reactive power
- The concept of power factor and $\cos \varphi$
- The concept of measuring methods
- Start current settings (C/k)
- Delay times
- Efficiency and losses
- Linear and circular switching modes
- PF-Controller design and schematics
- Programming the controller
- PF-Controller and resistive/inductive loads
- PF-Controller and induction motor loads
- Control range limits

ORDER INFORMATION POWER FACTOR CONTROL SYSTEM SYSTEM 220-240 V

Product no	Description	Pc	Page
MV1439-235	Power Factor Control Unit 3 x 230V, 50-60 Hz	1	67
MV1100-235	Load Resistor 3-ph 3.3 kW	1	181
MV1101	Load Reactor, 3-phase, 2.5 kVAr	1	181
MV1102	Load Capacitor, three-phase 2.8 kVAr	1	181
MV1500	Load Switch, 3-pole 16A	3	195
MV1420	Line Model 3-phase, 230 V 3-phase	1	72
MAT220118	Digital Multimeter	2	191
MAT220350	Digital Clamp Meter AC / DC current	2	188
MV1830-HF	Flex Set, 100 Safety Leads, Safety Plugs	1	198
MV1904	Flex Stand	1	199
Optional			
MV1009-405	Induction Motor Squirrel Cage, 400/230V 50-60 Hz 1,1 kW	1	51
MV1028-225	DC-Machine, 2.2 kW complete with interpoles 220V	1	50
MV1905	Shunt Regulator	1	57
MV1004	Machine Bed	1	58
MV1029	Protective Cover	1	178

Ref. 202

ORDER INFORMATION POWER FACTOR CONTROL SYSTEM SYSTEM 380-440 V

Product no	Description	Pc	Page
MV1439-405	Power Factor Control Unit 3 x 400V 50-60 Hz	1	67
MV1100-235	Load Resistor 3-ph 3.3 kW	1	181
MV1101	Load Reactor, 3-phase, 2.5 kVAr	1	181
MV1102	Load Capacitor, three-phase 2.8 kVAr	1	181
MV1500	Load Switch, 3-pole 16A	3	195
MV2221	Line Model 230 kV, 100 km, 400 V 3-phase	1	66
MV1103	Variable Transformer, 3-phase	1	177
MV1429	Connection Box / Terminal Board	1	177
MV1939	AC Power Energy Meter	2	187
MAT220350	Digital Clamp Meter AC / DC current	2	188
MV1830-HF	Flex Set, 100 Safety Leads, Safety Plugs	1	198
MV1904	Flex Stand	1	199
Optional			
MV1009-405	Induction Motor Squirrel Cage, 400/230V 50-60 Hz 1,1 kW	1	51
MV1028-225	DC-Machine, 2.2 kW complete with interpoles 220V	1	50
MV1905	Shunt Regulator	1	57
MV1004	Machine Bed	1	58
MV1029	Protective Cover	1	178

Ref. 205

MV4250 Asynchronous Wind Mill System including HVDC Light Transmission Cable

The total system is integrated in one single unit:

- Controls for asynchronous machine
- Necessary instruments
- Magnetizing capacitors
- Compensating inductances
- Variable resistive load
- HVDC-light cable (two distances)
- Advanced 4Q 3-ph line inverter which is manually, MMI- or PC-operated.

Background

Depending on energy prices, negative influence on the environment, running on the edge of available power, transmission costs and the risk of local black-outs the need for alternative energy sources is obvious.

Wind power has been existing in a smaller scale for decades but are now used as an important power producer in parallel with the classic energy sources. The former drawbacks like expensive turbines, generators, gear-boxes and conventional transmission lines together with disturbances on the environment are now overcome to a great extent.

It is now possible to use a cheap turbine with firm blades designed for floating speed with an operating range from low to higher speeds. The turbine is connected mechanically to a conventional asynchronous machine (self exciting induction motor), which is the cheapest and most sturdy machine available in the market.

For bigger units synchronous generators equipped with permanent magnets are standard. In this case we will study a type of wind mill used up to some hundred kW. These windmills can be put out in the sea along the coastline and the power is transferred to the grid network by HVDC-light cables on a floating voltage level which by means of modern technology is transformed to conventional 3-ph 50 (60) Hz energy.

Description

The Wind Mill Control Unit (MV4250) is designed to be connected to an external standard type induction machine (optional) to simulate the wind turbine, which speed can be varied.

By means of the MV4250 the asynchronous motor/generator will be self excited and deliver a lower or higher 3-phase voltage of different frequencies.

There is a continuously controllable built-in resistive load bank to give the induction generator different working points or break-down points.



By the built-in capacitor bank the excitation can be increased gradually to buffer increasing load. A group of compensating inductances will keep the voltage level within reasonable limits.

A 3-phase rectifier bridge will supply the output side with a floating DC-voltage which can either be loaded by the internal resistive loads or connected to a HVDC-light line model which is feeding an advanced 3-ph 6-pulse 4Q converter.

The converter is operating against the infinite bus in a floating voltage current limitation mode turning the DC-energy to 3-ph 50 (60) AC.

There are instruments for AC- and DC voltages and ammeters for AC-input power, inductive current and capacitive current together with a DC-ammeter on the output to give a clear view of the generator operation.

The rather complex procedure of turning floating voltage DC-energy to 3-ph 50 (60) Hz AC is studied thoroughly since most types of windmills are using this method. Jumpers will give possibilities to connect other instruments like watt-meters (optional).

Principle diagrams are printed on the front plate (see below).

... continuing MV4250 Asynchronous Wind Mill System

Technical Specifications

Minimum/maximum power by design 0,5 – 2,0 kVA input
 Magnetising capacitors by 3-step selector switch
 Compensating inductors by 3-step selector switch

Resistive load bank on DC-side continuously controlled by PWM-unit 3-phase rectifier block

V-meter for AC-input 250 V AC
 V-meter for DC-output 400 V DC
 A-meter for AC-input 6 A AC
 A-meter for capacitive current 6 A AC
 A-meter for inductive current 4 A AC
 A-meter for DC-output 6 A DC
 Short- and long HVDC cable model

Suitable induction machine std (or optional) 0,75 – 1,5 kW

Advanced 4Q-converter including software >1,5 kW

External alternative inputs from 3x230 V generator, ind. or synchr.,
 3x230 V power supply max 300 V DC

Power supply 3x400 VAC, 16A, 50–60 Hz

Dimensions 510x360x570 mm

Weight 45 kg

Examples of experiment setups

- Self exciting of an asynchronous motor/generator
- Working points depending on speed and capacitance
- Working characteristics depending on resistive loads
- The influence of compensating inductances
- Total efficiency depending on involved parameters
- Magnetising currents and risk for over-excitation
- Rotating currents
- Principles of floating speed and frequency
- HVDC-light cables
- Principles of DC energy transfer using a 4Q-converter operating in current limit mode at floating voltage
- Operating the main converter manually, via MMI or by PC

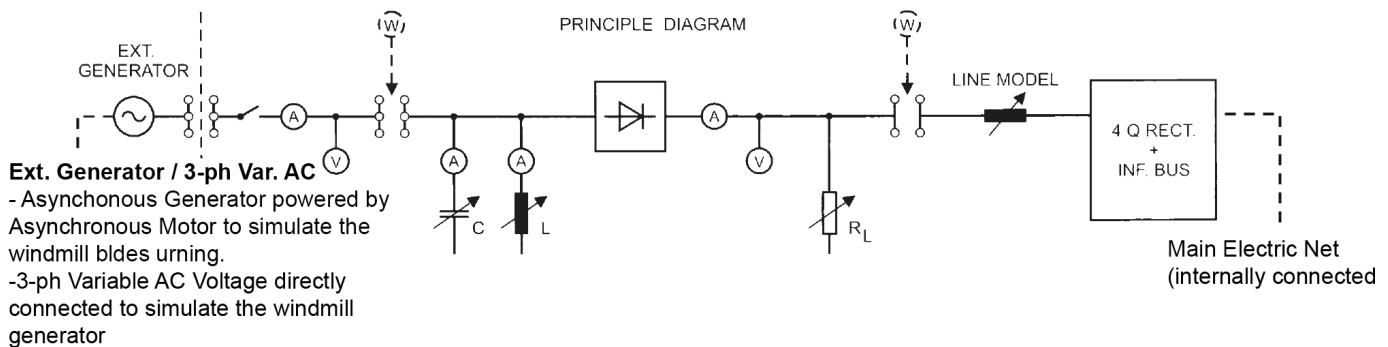

ORDER INFORMATION RENEABLE ENERGY - WIND MILL CONTROL

Product no	Description	Pc	Page
MV4250	Asynchronous Wind Mill System incl. HVDC Light Line	1	69
Optional 1			
MV1009-385	Induction Motor Squirrel Cage	2	49
MV1004	Machine Bed	1	58
MV1029	Protective Cover	1	178
MV4206-1	AC Motor Drive	1	65
Optional 2			
MV1830-HF	Flex Set, 100 Safety Leads, Safety Plugs	1	198
MV1904	Flex Stand	1	199

Ref.203

Transmission Line, Transformer & Protection Laboratory



In the electricity grid's power lines and cables, electricity is transported from the power plants to industries and housing. On the way it passes a number of stations where it is converted and distributed, all the way to our electrical outlets.

In this chain of transformers and power lines, losses occur, in addition various faults such as interruptions, short circuits, earth faults etc. With TERCO's training materials for line models, transformers and protective relays, you gain practical knowledge in the field.



MV1420 Line Model

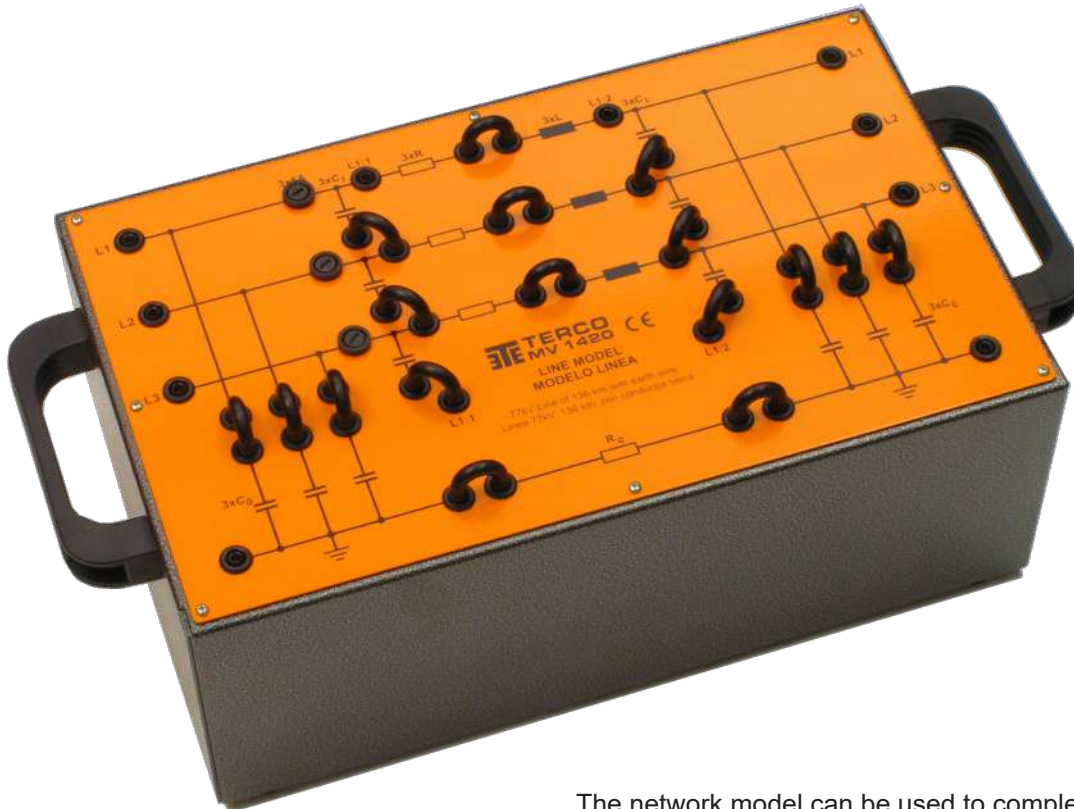

The model corresponds to a power transmission line of a length 136 km, voltage 77 kV, amperage 100 A, power rating 13 MW.

Technical Specifications

Voltage	220-240 V, three-phase (corresponding to 77 kV)
Amperage	5 A (corresponding to 100 A)
Line resistance	1.5 ohms
Line reactance	3.15 ohms

Line capacitance divided into capacitance to earth (4 μ F) and mutual line capacitance between phases (8 μ F).

Earth impedance	0.8 ohm
Fuses	5 A

Dimensions:	410 x 245 x 160 mm
Weight:	10 kg

The network model can be used to complete a series of experiments with transmission lines. Those listed and described in detail in the instruction manual include:

- Characteristic data of the line
- Voltage drop on the lines
- Short circuit tests
- Earth fault

The following studies can be made:

1. Measurements of characteristic data, resistance, reactance and capacitance of a line.
2. As transmission line:
Measurement of voltage drop and losses for different loads.
3. For two-phase and especially three-phase short circuit measurements with two three-phase transformers, one at each end.
4. For single-phase and two-phase earth fault measurements.

Terco reserves the right to make changes in the design and modifications or improvements of the products at any time without incurring any obligations

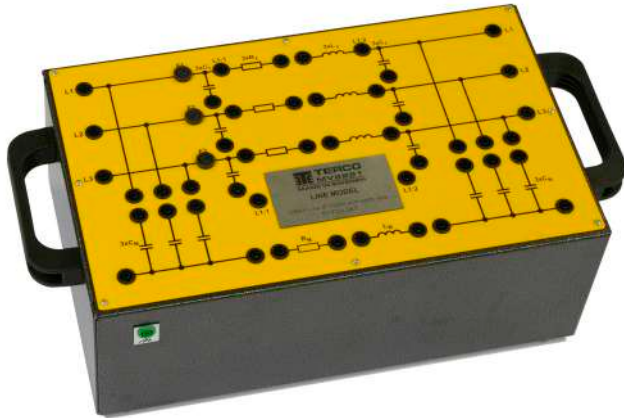

MV2221 Line Model

The network model can be used to complete a series of experiments with transmission lines. Those listed and described in detail in the instruction manual include characteristic data of the line. Voltage drop on the lines. Short circuit. Earth fault.

Technical Specifications

Line Model 230 kV, 100 km, 400 V 3-phase. Three-phase model of an overhead power transmission line 100 km long, voltage 230 kV and ability 110 MVA. Model value 400 V : R + 2.20 ohm, L 25 mH, C + 4uF, Co 2.5 uF.

Dimensions: 410 x 245 x 160 mm

Weight: 10 kg

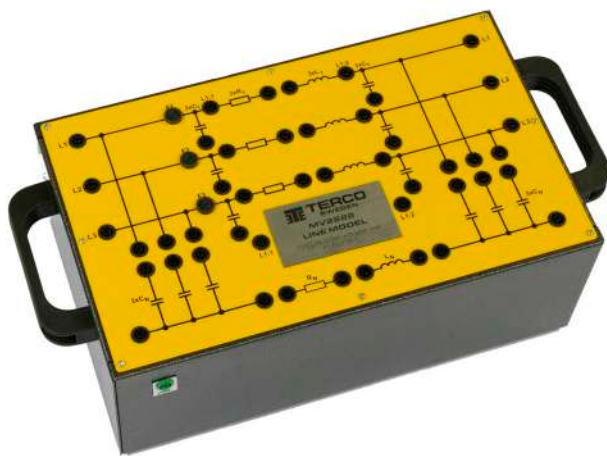

MV2222 Line Model

The network model can be used to complete a series of experiments with transmission lines. Those listed and described in detail in the instruction manual include characteristic data of the line. Voltage drop on the lines. Short circuit. Earth fault.

Technical Specifications

Line Model 11 kV, 5 km, 400 V 3-phase. Three-phase model of an overhead power transmission line 5 km long, voltage 11 kV and ability 5 MVA. Model value 400 V : R + 2.4 ohm, L 17 mH, C + 30 nF, Co 20 nF.

Dimensions: 410 x 245 x 160 mm

Weight: 10 kg



MV2225 Petersen Coil, Multi Terminal Unit

A Petersen coil is used together with OH-lines in the range of distribution voltage to medium voltage (MV). The most common fault is line-to-earth where the current is limited by the phase voltage from the two healthy leads divided by the capacitive impedance added by the arc resistance and the remaining zero sequence impedance.

Since this current is mainly capacitive it could be balanced by an inductance between the neutral point of the transformer and ground. That is to say: when a line-to-earth fault occurs it will be extinguished automatically by the current in the Petersen coil and the re-closing device will connect power again in a fraction of a second.

Normally a HV-line has a firm ground. However, in this case we may also study a 230 kV model because of tutorial aspects.

Each inductance coil has three steps to optimize the reactance value for each line of "11 kV", "70 kV" and "230 kV".

Technical Specifications

The 3 coils have following values:

L = 0.63 H and +/- 30 % terminals (70 kV)

L = 1.00 H and +/- 30 % terminals (230 kV)

L = 100 H and +/- 30 % terminals (11 kV)

MV2225 is to be used together with the Line Models MV1420, MV2221 and MV2222.

Dimensions: 410 x 245 x 160 mm

Weight : 11 kg

ORDER DETAILS FOR TRANSMISSION LABORATORY

Cat. Code	Description	pc	page
MV1420	Line Model 3-phase, 230V	1	73
Recommended peripheral equipment for MV1420			
MV1103	Variable Transformer, 3-phase	1	177
MV1429	Terminal Board	1	195
MV1100-235	Load Resistor 3-ph, 3.3kW	1	181
MV1107	Load Reactor, 3-ph, 3 kVAr	1	181
MV1102	Load Capacitor, 3-phase, 2.8 kVAr	1	181
MV1500	Load Switch, 3-pole 16A	2	58,195
MV1915	Transformer, 3-ph 2 kVA 50-60 Hz	2	78
MV1939	AC Power Energy Meter	2	187
MV1830-HF	Flex Set, 100 Safety Leads, Safety Plugs	1	198
MV1904	Flex Stand	1	199
Optional Line Models and equipment:			
MV1424	Line Model, 3-ph, 400V, one phi-link (40kV, 40km)	1	74
MV1425	Line Model, 3-ph, 400, double phi-link (220kV, 100km)	1	74
MV1438	Cable Line Model 400V, 3-phase (11kV, 5km)	1	75
MV2221	Line Model 400V 3-phase (230kV, 100km)	1	76
MV2222	Line Model 400V, 3-phase (11kV, 5km)	1	76
MV2225	Petersen Coil, Multi Terminal	1	76
MV1439-235	Power Factor Control Unit	1	67
Additional Equipment: Measuring and Data Acquisition for PC			
MV1943	Measuring and Control Module	1	185
MV2609	Control and Data Acquisition Software	1	186
Alternative instrument			
MV1922/23	Ammeter 0-10A, AC/DC	4	191
MV1926	Voltmeter 0-50-250-500V AC/DC	3	191
MV1937	Wattmeter 1-ph, 1-5A; 50-250-500V AC/DC	3	192
MV1929	Power Factor Meter 3-ph, 0-5A, 230V	1	192
MV1976	Power Factor Meter 3-ph, 0-5A, 400V	1	192

Ref. 253

Terco reserves the right to make changes in the design and modifications or improvements of the products at any time without incurring any obligations

Transformers

MV1911 Transformer Single-Phase

Ratings Single-phase 1 kVA, 50-60 Hz
 Primary: 230 V \pm 5 %
 Secondary: 4 x 57.5 V \pm 5 %

The secondary winding is divided into four windings for series or parallel connection.

No load losses $P_o = 25$ W
 Impedance voltage $e_k = 8$ %
 Resistance voltage $e_k = 3$ %

MV 1911 can be used for determination of operating characteristics, losses and efficiency of a single-phase transformer by means of no load, short-circuit and load tests. The transformer has safety sockets mounted on the frontpanel with mimic diagrams.

Dimensions: 210 x 150 x 210 mm
 Weight: 22 kg

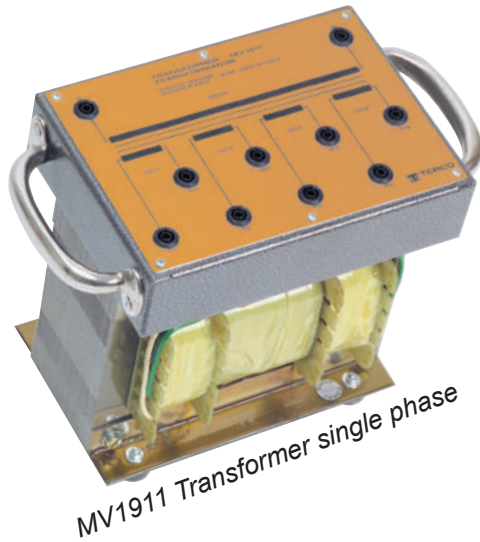

MV1915 Transformer 3-Phase

Ratings Three-phase, 2 kVA, 50-60 Hz,
 230/2 x 66.5 V per phase
 Primary 0-133-230 V \pm 5 % per phase
 Secondary Two 66.5 V windings per phase,
 each winding having tapings for
 0-38.4-44-66.5 V (\pm 5 %)

The tapings are so arranged that 230 V (star or delta connection) and 133 V (star, delta or zig-zag connection) can be obtained for all standard connections. This transformer has safety sockets mounted on the frontpanel with mimic diagrams.

No load losses $P_o = 35$ W
 Impedance voltage $e_k = 8$ %
 Resistance voltage $e_k = 3$ %

With MV 1915, asymmetrical loading and parallel connection of three-phase transformers for different three-phase combinations on the primary and secondary side, can be studied. It can also be used for determination of operating characteristics, losses and efficiency.

Dimensions: 300 x 190 x 345 mm
 Weight: 33 kg





MV1972 Transformer 3-Phase

This transformer has an E-type core and is suitable for setting up a variety of circuits for 3-phase transformers. MV 1972 has safety sockets mounted on a front-panel with mimic diagrams.

General Data

Power rating	Three-phase 2 kVA, 50-60 Hz
Primary voltage	400 V \pm 5 % or 230 V \pm 5 % per phase
Secondary voltage	2 x 66.5 V \pm 5 % per phase
Test voltage	2.5 kV
Efficiency	92 %
Percentage impedance voltage	4 % approx.
Dimensions	350 x 165 x 260 mm
Weight	30 kg

Experiment Transformers

These transformers are designed for studies of single and three-phase transformers, by the completion of a series of experiments, which are described in detail in the instruction manuals.

These include:

- Efficiency and short circuit impedance.
- Waveform of the no-load current.
- Inrush current.
- Three-phase connections.
- Unbalanced loading.

Sectioned Transformer

Not for connecting to the main and operation!

The machines are sectioned about 90° allowing all the main components to be demonstrated clearly and in an educational way. Please note : It is not possible to do any practical experiments with the machines.



MV1915-C Three-phase Transformer

This transformer is cut-away to show the windings, coils, terminals, insulation, iron core etc.

Rated power	2 kVA
Dimensions	300 x 190 x 345 mm
Weight	27 kg

Please note : It is not possible to do any practical experiments with the transformer.

ORDER DETAILS FOR TRANSFORMER LABORATORY			
Cat. Code	Description	pc	page
MV1911	Transformer Single-Phase	1	78
MV1915	Transformer 3-Phase 230V	1	78
MV1972	Transformer 3-Phase 400V	1	79
Recommended peripheral equipment for Transformer Laboratory			
MV1103	Variable Transformer, 3-phase	1	177
MV1429	Terminal Board	1	195
MV1100-235	Load Resistor	1	181
MV1101	Load Reactor, 3-phase, 2.5 kVAr	1	181
MV1102	Load Capacitor, 3-phase, 2.8 kVAr	1	181
MV1500	Load Switch, 3-pole 16A	1	58,195
MV1939	Power Energy Meter	1	187
MV1830-HF	Flex Set, 100 Safety Leads, Safety Plugs	1	198
MV1904	Flex Stand	1	199
MAT220118	Digital Multimeter	1	191
Optional:			
MV1915-C	Transformer 3-phase, sectioned	1	79
MV1931	Current Transformer	1	196
Alternative instruments instead of MV1939 above:			
MV1922/1923	Ammeter	4	191
MV1926	Voltmeter	2	191
MV1937	Wattmeter	3	192

Ref. 252

Protective Modules - Fully IEC 61850 compliant

MV1450 Line Multi Protection Module



The MV1450 Line Multi Protection Trainer module is intended for advanced training in modern line distance protection technology.

It is equipped with the fully IEC61850 compliant ABB protection REF630 which is one of the most modern and sophisticated protection units in the product family of Intelligent Electronic Devices (IEDs).

REF630 is designed for protection of transmission and distribution networks.

The use of a highly advanced IED enables great possibilities to perform a wide range of laboratory experiments.

The protective relay REF630 used in MV1450 enables the student to learn and explore how to protect a variety of different power line configurations from various fault conditions.

General Features

- Colour coded power inlet- and outlets for easy recognition of each phase.
 - Mimic diagrams of the circuit along with large clear symbols printed on the front panel
- Power bus circuit breaker switch:
- A two state switch (ON/OFF) with LED indication of CB (Circuit Breaker) status.
 - Internal circuitry prevents operation of the CB during an unacknowledged trip.
- Trip reset button:
- Button for quick reset of LEDs and acknowledgement of a trip.
 - Control, monitoring and protection integrated in one IED
 - Fully IEC 61850 compliant.
 - Four independent parameter setting groups.
 - Large HMI with single line diagram.
 - RJ-45 interface for communication with PC.
 - Protection and Control IED Manager PCM600: Advanced software for configuration and parameter setting.

Technical Specification

Power Supply: 1-ph 220 - 240 V, 50 - 60 Hz
Possible to supply a compatible device with power

Power bus: 3ph, 400VAC, 2A

Dimension: 483 x 356 x 422 mm.

Weight: 37 kg

Protective earth: one 4mm safety connector for external components at the rear of the unit.

REF630 Important Protection functions

- Capable of a 5 zone full-scheme high-speed line distance protection with mho^*), bullet and quadrilateral characteristics.
- Three stages of over-current protection (Low, high and instantaneous)
- Directional earth-fault protection
- Over-voltage protection
- Over-power protection (configurable direction)

**) In order to retain dependability and security in cases of close-in faults when the loop voltage is zero, mho distance elements use cross-phase and/or memory polarization.*

Full access to protections relays including parameter setting and Disturbance Records is possible via a standard web browser.

It is possible to view important analogue current and voltage sinus waveform vectors in a suitable diagram, together with protection's binary input and output status for in-depth fault analysis after such an event has occurred.

ORDER DETAILS FOR MV1450 LINE MULTI PROTECTION LABORATORY			
Cat. Code	Description	pc	page
MV1450	Line Multi Protection Trainer	1	78
Recommended peripheral equipment for MV1450			
MV1450-COMP	PC with installed & pre-programmed software for MV1450	1	78
MV1103	Variable Transformer, 3-phase	1	177
MV1429	Terminal Board	1	195
MV1100-235	Load Resistor 3-ph, 3.3kW	1	181
MV1101	Load Reactor, 3-phase, 2.5 kVAr	1	181
MV1102	Load Capacitor, 3-phase, 2.8 kVAr	1	181
MV1500	Load Switch, 3-pole 16A	2	58,195
MV1959	Rheostat 200W, 50 ohm,, 2A	1	183
MV2221	Line Model 230kV, 100km, 400V, 3-phase	2	73
MV2222	Line Model 11kV, 5km, 400V 3-phase	2	73
MV1922/23	Ammeter 0-10A, AC/DC	2	191
MV1926	Voltmeter 0-50-250-500V AC/DC	2	191
MAT220350	Digital Clamp Meter AC / DC current	1	188
MV1830-HF	Flex Set, 100 Safety Leads, Safety Plugs	1	198
MV1904	Flex Stand	1	199

Ref. 251A

Power supply of modules

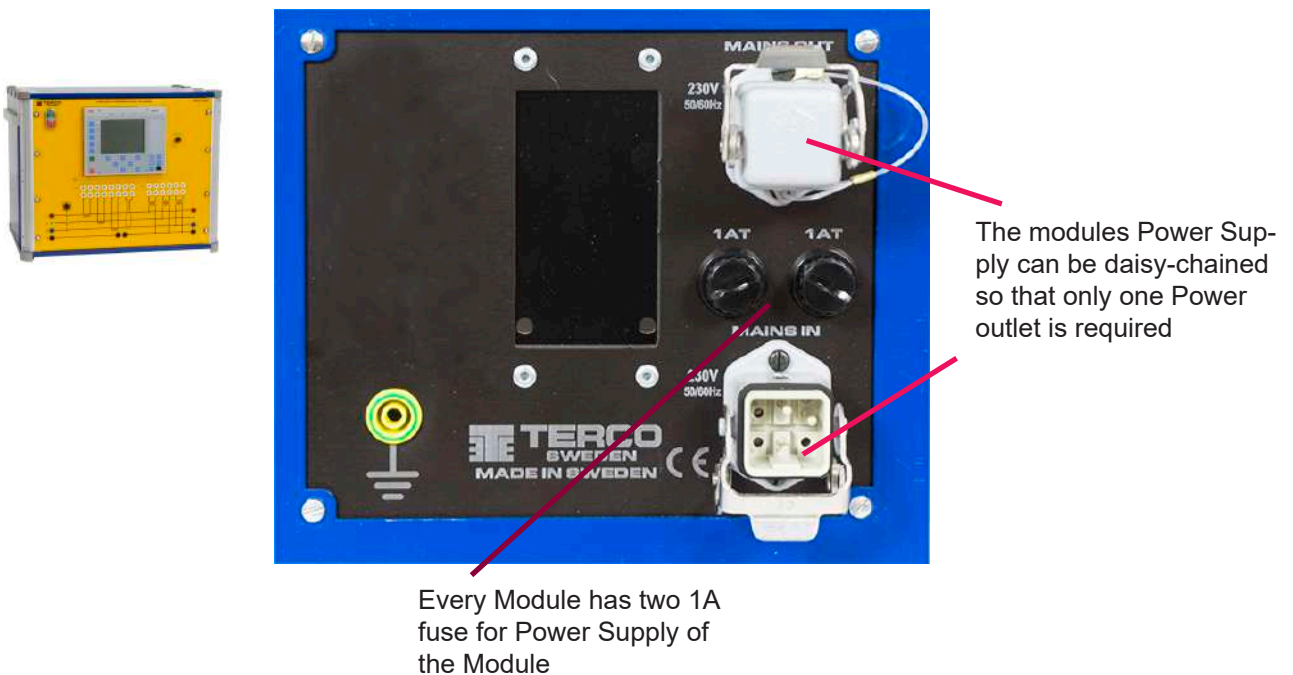

Terco reserves the right to make changes in the design and modifications or improvements of the products at any time without incurring any obligations

MV1455 Differential Relay Module



General Features

- Colour coded power inlet- and outlets for easy recognition of each phase.
 - Mimic diagrams of the circuit along with large clear symbols printed on the front panel.
- Power bus circuit breaker switch:
- A two state switch (ON/OFF) with LED indication of CB (Circuit Breaker) status.
 - Internal circuitry prevents operation of the CB during an unacknowledged trip.
- Trip reset button:
- Button for quick reset of LEDs and acknowledgement of a trip.
 - Control, monitoring and protection integrated in one IED
 - Fully IEC 61850 compliant.
 - Four independent parameter setting groups.
 - Large HMI with single line diagram.
 - RJ-45 interface for communication with PC
 - Three power lines; 1 incoming power line and 2 outgoing. Each line contain three phases L1, L2, L3 and Neutral wire.
 - 12 Current Transformers which enables the student to study various CT-connections.
 - Protection and Control IED Manager PCM600: Advanced software for configuration and parameter setting.
 - Front panel switches that enable the student to test differential protection on a double-busbar.

The MV1455 Differential Relay Module module is intended for advanced training in modern differential protection technology.

It is equipped with the fully IEC61850 compliant ABB RET615 protective relay which is one of the most sophisticated protection unit in the product family of intelligent electronic devices (IEDs).

RET615 is designed for differential protection of transformers, generators, line sections and their combinations.

The use of a highly advanced IED enables great possibilities to perform a wide range of laboratory experiments.

The protective relay RET615 used in PTG1455 enables the student to learn and explore how to protect a variety of different power transformer connections with a differential protection scheme.

Technical Specification

Power Supply: 1-ph 220 - 240 V, 50 - 60 Hz
Possible to supply a compatible device with power
Power bus: (3-ph) 400V AC/ 2A with 4 mm safety connectors

Dimension: 357 x 483 x 420 mm
Weight: 37 kg

Protective earth: one 4mm safety connector for external components at the rear of the unit.

RET615 Important Protection Functions

- Differential Fault Protection
- Three-phase non-directional overcurrent protection, low, high and instantaneous stage
- Non-directional earth-fault protection, low and high stage
- Negative-sequence overcurrent protection
- Residual overvoltage protection

Full access to protections relays including parameter setting and Disturbance Records is possible via a standard web browser.

It is possible to view important analogue current and voltage sinus waveform vectors in a suitable diagram, together with protection's binary input and output status for in-depth fault analysis after such an event has occurred.

ORDER DETAILS FOR MV1455 DIFFERENTIAL RELAY LABORATORY			
Cat. Code	Description	pc	page
MV1455	Differential Relay Module	1	83
Recommended peripheral equipment for MV1455			
MV1455-COMP	PC with installed & preprogrammed software for MV1455	1	78
MV1103	Variable Transformer, 3-phase	1	177
MV1429	Terminal Board	1	195
MV1100-235	Load Resistor 3-ph, 3.3kW	1	181
MV1101	Load Reactor, 3-phase 2.5kVAr	1	181
MV1102	Load Capacitor, 3-phase, 2.8 kVAr	1	181
MV1500	Load Switch, 3-pole 16A	1	58,195
MV1957	Rheostat 200W, 5 ohm, 6.3A	3	183
MV1959	Rheostat 200W, 50 ohm,, 2A	1	183
MV1400	Push Button Panel	1	195
MV1911	Transformer 1-phase, 1kVA, 50-60 Hz	1	75
MV1915	Transformer 3-phase, 2kVA, 50-60 Hz	1	75
MV1922/23	Ammeter 0-10A, AC/DC	5	191
MV1926	Voltmeter 0-50-250-500V AC/DC	2	191
MAT220350	Digital Clamp Meter AC / DC current	1	188
MAT220118	Digital Multimeter	1	191
MV1830-HF	Flex Set, 100 Safety Leads, Safety Plugs	1	198
MV1904	Flex Stand	1	199

Ref. 251B

Power supply of modules



The modules Power Supply can be daisy-chained so that only one Power outlet is required

Every Module has two 1A fuse for Power Supply of the Module

HV9000 High Voltage Modular Training Set



Energy Conservation

Energy conservation is becoming increasingly important. One method of conserving energy is by reducing losses. An important technique used to reduce losses is to transfer energy through High Voltage Transmission Lines. However, High Voltage is also difficult to handle properly and there are many technical problems to overcome to make handling of High Voltage even more efficient. With TERCO High Voltage Modular Training Set many of these problems can be studied.

TERCO High Voltage Modular Training Set HV9000 is based on a system of components made with the highest precision and can be used to build systems both for teaching and research as well as for industrial routine and type tests. The assembly of a test setup is easily done and requires no special tools. The system gives highly accurate values and can even be used for calibration purposes.

General Specifications:

Modular design makes it quick and easy to set up different test circuits, allowing maximum time for experimentation. Parts are easy to handle due to low weight.

All components, with the exception of the Test Transformer, can be handled by one person. Specially designed joints facilitate interconnection of components are designed to minimize partial discharge. It's easy to follow equipment manuals and experiment manuals.

Major types of Electrical Power Equipment

- Power and Distribution Transformers (oil insulated and resin cast), Reactors
- Rotating Machines
- Power Cables
- Instrument Transformers
- Switch Gears, Isolators
- Power Capacitors
- Insulators
- Surge Arresters
- Bushings etc.

Each type of equipment requires different types of High Voltage Tests depending on their expected operational requirements.

Experiments Manual

The TERCO High Voltage Experiments Manual is a comprehensive manual which contains laboratory exercises with detailed text and figures how to connect the equipment and perform the experiment

List of Experiments

1. Generation and Measurement of Alternating Voltage

- A. Capacitive Divider
- B. Sphere gaps and standard tables

2. Generation and Measurement of Direct Voltages 1

- A. Load characteristics of Rectifiers
- B. Measurement of Ripple Factor

3. Generation and Measurement of Direct Voltages 2

- A. Greinacher Voltage Doubler Circuit
- B. Polarity effect and Insulating screens

4. Generation of impulse voltages

- A. Lightning impulse voltage
- B. Single stage impulse voltage circuits
- C. Peak value measurements with sphere gaps
- D. Break down probability

5. Measurement of impulse voltages

- A. Multiplex circuit after Marx
- B. Impulse voltage divider
- C. Impulse voltage time curves

6. Power frequency and Impulse Voltage Tests on Power Transformer

- A. Specifications for high voltage tests
- B. Insulation coordination
- C. Break down test for insulating oil (Test oil is not supplied by TERCO)
- D. Transformer test with alternating voltage (Transformer is not supplied by TERCO)
- E. Transformer test with lightning impulse voltage (Transformer is not supplied by TERCO)

7. Experiment on solids and Insulating Liquids

- A. Breakdown strength of hard board plate (Test oil and hard board is not supplied by TERCO)

8. Experiment on Partial Discharge and Corona

- A. Partial discharge at Needle electrode in air
- B. Measurement in corona cage

9. Experiment on PD and Gliding Discharges

- A. PD measurement in High Voltage Insulation
- B. Measurement of Onset Voltages of Gliding Discharge

10. Breakdown of gases

- A. Townsend mechanism
- B. Streamer mechanism

Terco reserves the right to make changes in the design and modifications or improvements of the products at any time without incurring any obligations

Test Room

It is very important to house the HV9000 in a specially designed test enclosure. This must be built in accordance with the guidelines below, to a high standard and local safety regulations must be followed. For a single stage kit a floor space of 4 x 5 m is recommended, with a height of 2.5-3 m. Since voltages in excess of 1000 V are generated the safety regulations must be carefully followed. Fencing and grounding of the Test Room are very important.

Safety Equipment

The test area should be enclosed by a metal fence of at least 1.8 m in height and the mesh width not exceeding 50 mm. All doors leading into the test room must be equipped with door contacts, which lock when the door is closed.

All contacts shall be connected in series and fed to the appropriate sockets on the control desk. Red and green warning lamps must be installed on all doors leading into the test room. These lamps should be connected to the control desk.

Earthing (grounding)

Earthing is very important, absolutely necessary for a good test room for high voltage test equipment. Connection should be made with low inductance connections copper cables which connect all components

of the high-voltage circuit that must be earthed to ONE earth terminal.

Earthing connections should be made without loops. A modern earthing technique is to cover the lab floor with Aluminum sheets (2mm thickness) which are bolted to the floor and connected internally with copper cables and to earth. 4 aluminum sheets 2 x 1 m are included in our Safety Cage (HV-CAGE 1).

Any screening surfaces, test objects and/or measuring instruments should be connected to the same earthing point which should be located inside the safety fence and have a lower earthing resistance than the surrounding building.

In any case the earthing resistance should not exceed 2 ohm or local regulation values.

Installation and Training

The HV-Lab must be installed inside an appropriate protective shell. If installation and training is ordered from TERCO, the Safety Cage must also be included (compulsory).

Height of the Testroom :

1-Stage: min 3.0 m

2-Stage: min 3.5 m

3-Stage: min 4.0 m



Power Supply for HV9000 is 220/230V, 50/60Hz single phase.
Fuse 25A D characteristic.

Good earthing quality is recommended and should be carried out in accordance with local regulations.



HV Cage Suggestion For Layout Of HV9000 Setup

Height of the Testroom: 1-Stage: min 3.0m; 2-Stage: min 3.5m; 3-Stage: min 4.0m

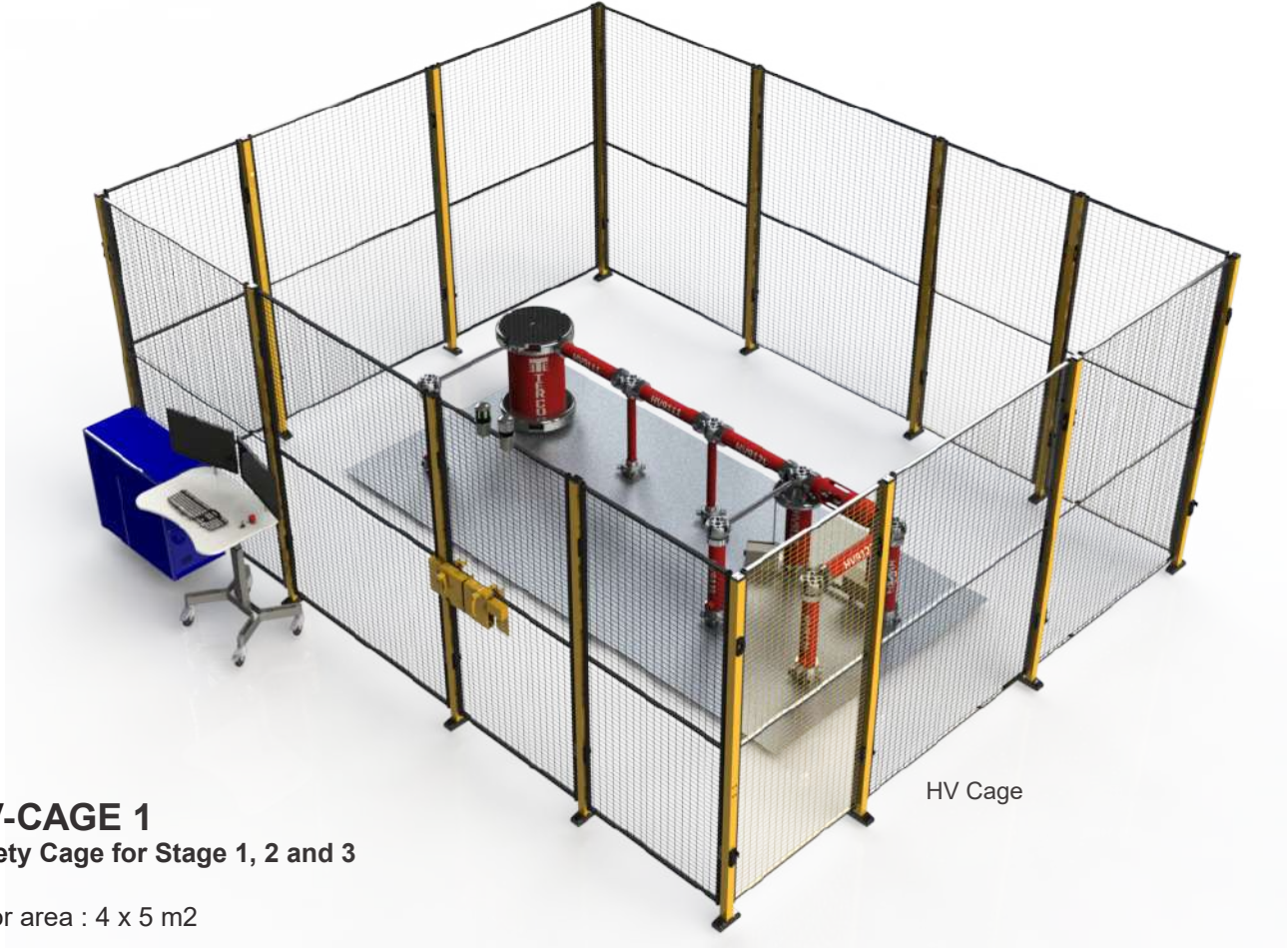

HV Cage

HV-CAGE 1

Safety Cage for Stage 1, 2 and 3

Floor area : 4 x 5 m²

Comprising :

- Net-section 1.5 m x 2.2 m 8 pcs
- Net-section 1.0 m x 2.2 m 5 pcs
- Safety door with Master lock 1 pc
- Pillar 50 x 70 mm, height 2.3 m 14 pcs
- Green & Red Lamps

Aluminum floor (8sqm) comprising:
 4 pcs aluminum sheets 2000 x 1000 x 2mm
 Set of Cables and Screws.

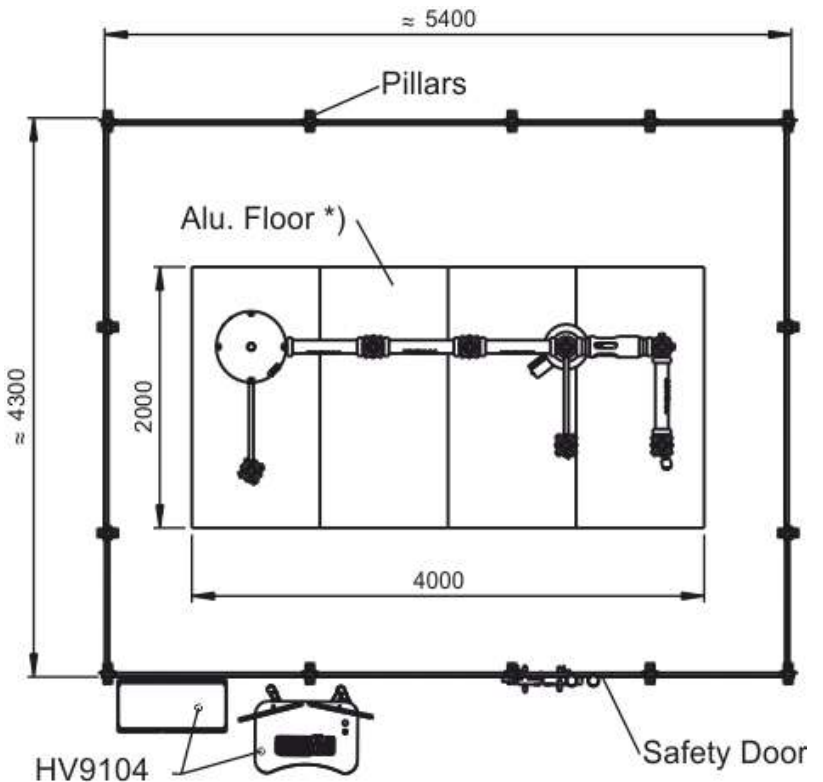

Safety Door Lock



Green & Red Lamps



Different Experiment Setups And Safety Net Installation

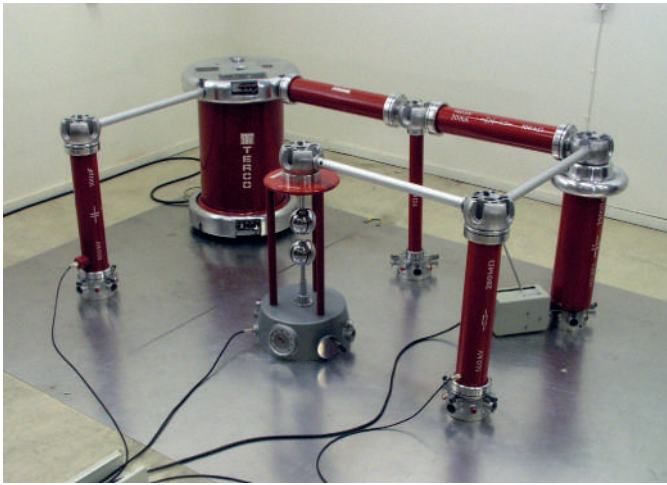

Measurement of flashover

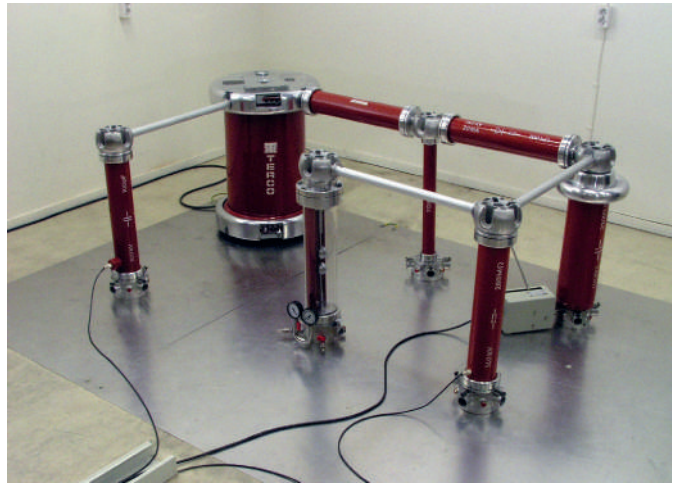

Measurement of flashover voltage in vacuum and under pressure

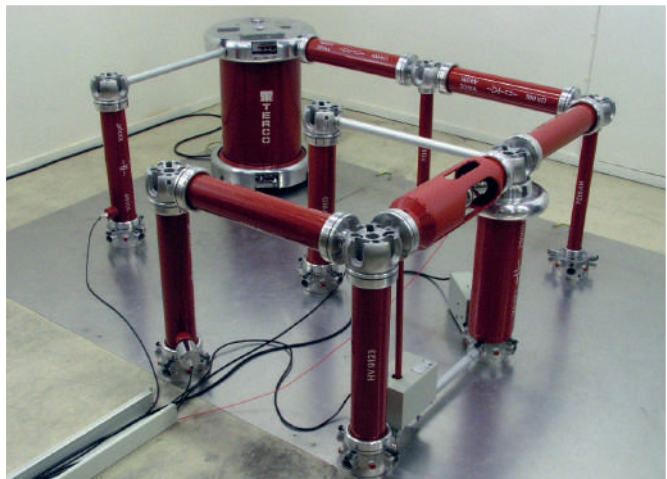

Impulse Set-up



Installation of Safety Fence



Demonstrating easy assembly

AC Voltage - Test Set-Up



Single-stage AC Voltage Test Set-up



3-stage AC Voltage Test Set-up

Technical Specification

Single-stage		Two-stage		Three-stage	
Rated no load voltage 100 kV (rms)		Rated no load voltage 200 kV (rms)		Rated no load voltage 300kV (rms)	
Output:		Output:		Output:	
Continuous	5 kVA	Continuous	5 kVA	Continuous	5 kVA
< 60 min	10 kVA	1 Hr. on	10 kVA	1 Hr. on	10 kVA
Rated current	50 mA	Rated current	25 mA	Rated current	16 mA
	100 mA		50 mA		32 mA
Impedance voltage	4% approx.	Impedance voltage	7% approx.	Impedance voltage	4% approx.
Frequency	50/60 Hz	Frequency	50/60 Hz	Frequency	50/60 Hz

Basic Components for Single-stage AC Set-up (no test apparatus)

HV9104	Control Desk	1
HV9105	Test Transformer	1
HV9107	Discharge Rod	1
HV9108	Connecting Rod	1
HV9109	Connecting Cup	1
HV9110	Floor Pedestal	1
HV9141	Measuring Capacitor	1
HV9130-AC	Low Voltage Divider	1

Cables and connectors are included



2-stage AC Voltage Test Set-up

DC Voltage Test Set-Up



Single-stage DC Voltage Test Set-up (In the picture above AC-divider + Connecting Rod incl.)

Technical Specification

Single-stage		Two-stage		Three-stage	
Rated no load voltage	140 kV	Rated no load voltage	280 kV	Rated no load voltage	420 kV
Rated current	13 mA	Rated current	10 mA	Rated current	7.5 mA

Basic Components for Single-stage DC Set-up (no test apparatus).

HV9104	Control Desk	1
HV9105	Test Transformer	1
HV9107	Discharge Rod	1
HV9108	Connecting Rod	2
HV9109	Connecting Cup	3
HV9110	Floor Pedestal	3
HV9111	HV Rectifier	2
HV9112	Smoothing Capacitor	1
HV9113	Measuring Resistor	1
HV9114	Earthing Switch	1
HV9119	Spacer Tube	2
HV9124	Insulating Rod	1
HV9130-DC	Low Voltage Divider	1
HV9138	Top Electrode	1

Cables and connectors are included



2-stage Impulse Voltage Test Set-up



3-stage DC Voltage Test Set-up

Impulse Voltage - Test Set-Up



Single stage Impulse Voltage Test Set-up (In the picture above AC-divider + Connecting Rod incl.)

Technical Specification

Single-stage		Two-stage		Three-stage	
Rated DC charging voltage	140 kV	Rated DC charging voltage	280 kV	Rated DC charging voltage	420 kV
Maximum stored energy with: 1. HV9112 (25 nF)	245 J	Maximum stored energy with: 1. HV9112 (25 nF)	490 J	Maximum stored energy with: 1. HV9112 (25 nF)	735 J
Voltage efficiency (approx)	92 %	Voltage efficiency (approx)	92 %	Voltage efficiency (approx)	92 %

Basic Components for Single-stage Impulse Set-up (no test apparatus)					
HV9104	Control Desk	1	HV9130-IMP	Low Voltage Divider	1
HV9105	Test Transformer	1	HV9121	Charging Resistor	1
HV9107	Discharge Rod	1	HV9122	Wave Front Resistor	1
HV9108	Connecting Rod	2	HV9123	Wave Tail Resistor	1
HV9109	Connecting Cup	7	HV9124	Insulating Rod	2
HV9110	Floor Pedestal	7	HV9125	Sphere Gap	1
HV9111	HV Rectifier	2	HV9126	Drive for Sphere Gap	1
HV9112	Smoothing Capacitor/Impulse Capacitor	1	HV9138	Top Electrode	1
HV9113	Measuring Resistor	1	Measuring and Control Equipment		
HV9114	Earthing Switch	1			
HV9119	Spacer Tube	5	HV9130-DC	Low Voltage Divider	1
HV9120	Load Capacitor	1	HV9132	Electronic Trigger Sphere	1

Impulse Voltage - Typical Configurations

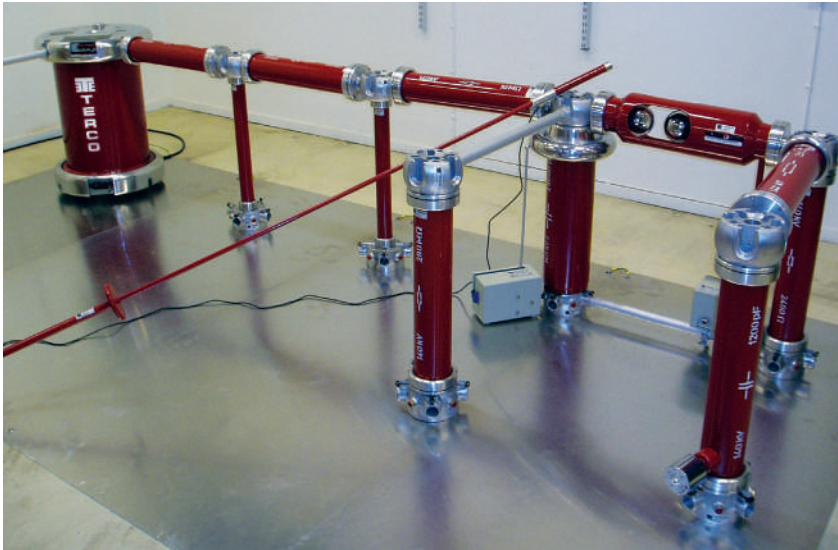

Single-stage Impulse Voltage Test Set-up Discharger Rod on the Capacitor

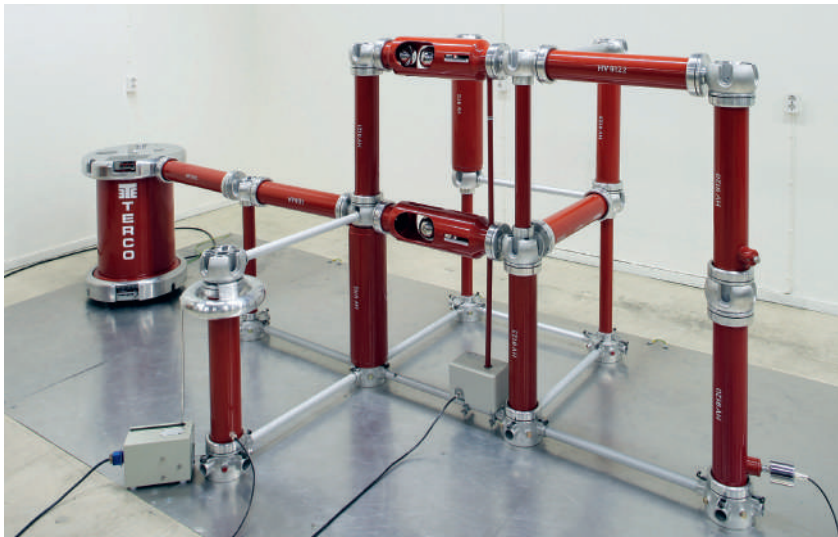

2-stage Impulse Voltage Test Set-up



3-stage Impulse Voltage Test Set-up

HV9104 Data Acquisition And Control Unit (DAQC)



The TERCO HV9104 DAQC unit is a unique solution for the comprehensive control of High Voltage AC, DC and Impulse test equipment. Via the latest TERCO DAQC software included in the package, the high-speed acquisition and presentation of real-time test measurement data, and system measurement values, can be viewed and manipulated easily on the attractive user interface comprising of 2 high-quality displays, keyboard, mouse and PC

Both manually-controlled and automated test sequences with data recording are possible. Test measurement data can be exported to EXCEL or CSV file-format for easy calculations or importation to popular 3rd-party software such as MATLAB.

The HV9104 DAQC comprises of 2 physical modules, the Control Module and the Switching Cabinet Module.

The Control Module houses a Dual Screen User Interface including all control elements for manual and automated operation of the high voltage test equipment.

All control module components including PC equipped with the TERCO DAQC software, Emergency Stop

button and Key Operated Mains Switch are mounted on an easily maneuverable roller-table with motorized height-adjustment for optimized versatility and user-comfort.

The Switching Cabinet Module contains all equipment for the actuation of commands received from the Control Module. The equipment includes the motor-operated regulating unit which consists of a ring-core regulating transformer and an isolating transformer.

The regulating module, which includes contactors, over-current tripping relays and equipment protection components, serves to energize the High Voltage test transformer HV9105.

Data Acquisition and Control Unit HV9104 replaces Control Unit HV9103.

All measurement components, pneumatics drive components and protection components for personal safety are also contained in the Switching Cabinet Module. The unit is powered via a standard 230V CEE socket. All controllable TERCO Test Apparatus can be remotely

maneuvered via the HV9104 DAQC. TERCO HV9104 DAQC together with the HV9105 Test Transformer are the basic components for every configuration of high voltage test setups, whether it be for HVAC, HVDC, or HV Impulse testing.

Data acquisition / monitoring / control

Reference standards: IEC60060-1, IEC60060-2, IEC61083-2
 PC: Windows PC, monitor, keyboard, mouse
 Digitizer: 12 bit, 200MS/s

- Programmable voltage sequence and capture control.
- Measurement display of HV AC / HV DC / Impulse output voltages:
0 - 300kV/420kV
- Measurement display of input values: 0-250V AC voltage, 0-25A AC current
- Waveform display of HV AC/DC/Impulse
- Impulse trigger sequence control (Auto/Manual)

Digital output and control

- Earthing Switch (HV9114)
- Sphere Gap (HV9125 / HV9126)
- Measuring spark Gap (HV9133)
- Vessel for Vacuum and Pressure (HV9134)
 - HV9134-A1 Vacuum Pump
 - HV9134-A2 Compressor
- Door contact and lights etc.
- Report generation and Export capability

Dimension and weight Control Unit:

Approx: 800 X 1050 X 1350 mm.
Electrically Height- Adjustable
 Approx.: 40 kg

Dimension and weight Switching Cabinet:

Approx.: 800 X 550 X 1100 mm
 Approx.: 250 kg

Supply Voltages: 230V 50/60 Hz
 Power rating: 5kVA continuous and 10kVA, 2 min. duty

Environment

Temperature range: 5-40 °C
 Humidity: 20-80% relative (non-condensing)

The HV9104 Control and Data Acquisition Unit replaces the HV9103 Control desk which is no longer produced.

Terco reserves the right to make changes in the design and modifications or improvements of the products at any time without incurring any obligations

HV9105 Test Transformer



Application.

Test transformer with coupling winding for cascade connection to produce AC high voltage. The transformer consists of three windings with insulating shell and top and bottom corona free Aluminum shielding electrodes.

The insulation cylinder is made of epoxy resin with glass fibre reinforcement and coated with anti tracking varnish.

The first exciter winding is a double winding 2x220V for connecting to approx. 220V (parallel connection) or 220 + 220V for connecting to approx. 440V (series connection) The series connection will require 50% of the parallel connection current.

The second winding is the HV winding of 100 kV connected in series.

The third winding, known as the "Coupler Winding" is provided for cascade connections of transformers.

The coil is vacuum impregnated and insulated with high quality grade transformer oil.



Three HV9105 connected in cascade

Technical data

Number of phases:	Single
Frequency:	50/60 Hz
Rated voltage:	100kV
Rated capacity:	10kVA
Rated current:	0.1 A
Short circuit impedance:	≤ 10%
PD under rated voltage:	≤ 5 pC

Dimensions (height x diam.): 845 x 550 mm
Weight: 220 kg

Basic Elements For Ac/Dc/Impulse Set-Ups



HV9111 Silicon Rectifier

Technical data

Inverse Peak voltage:	140 kV
Rated current:	20 mA
Protective Resistor:	100 k Ω
Length/ Height:	743 mm
Weight:	8 kg

Application

Rectifier for use in impulse voltage and DC voltage generation.



HV9112 Impulse Capacitor

Technical data

DC and Impulse voltages:	140 kV
Capacitance:	25nF
Length/Height:	743 mm
Weight:	20 kg

Application

Impulse capacitor for generation of impulse voltages. It can also be used as smoothing capacitor in DC voltage generation.



The picture shows HV9130 mounted on HV9120.

HV9120 Load Capacitor

Technical data

DC and Impulse voltages:	140 kV
Capacitance:	1.2nF
Length/Height:	743 mm
Weight:	9 kg

Application

Load capacitor and high voltage divider capacitor for measurement of impulse voltages.



HV9141 Measuring Capacitor

Technical data

AC voltages:	100 kV
Capacitance:	100 pF
Length/Height:	743 mm
Weight:	9 kg

Application

High voltage divider capacitor for measurement of AC voltages.



HV9130 Low Voltage Divider

Technical data

Measuring Range	10-150 kV
Optional	300 kV - 450 kV
Weight:	0.4 kg



HV9132 Electronic trigger sphere

Technical data

Measuring Range:	100-1000 $\hat{U}/\sqrt{2}$ kV
Dimensions:	Diam. 100 mm
Weight:	1 kg

Application

Incorporates the Low Voltage Capacitors and the 50 ohm cable adapter. It is plugged in to the UHF socket of the load capacitor and connects the Impulse Voltage Meter by means of co-axial cable.



HV9113 Measuring Resistor

Technical data

DC voltage:	140 kV
Resistance:	280 M Ω
Rated continuous current:	0.5 mA
Length/ Height:	743 mm
Weight:	5 kg

Application

High voltage resistor for measurement of DC voltages.



HV9121 Charging Resistor

Technical data

Impulse voltage:	140 kV
Resistance:	10 M Ω
Length/ Height:	743 mm
Weight:	5 kg

Application

Charging resistor for multistage impulse voltage test equipment and current limiting resistor in DC voltage generation.



HV9122 Wave Front Resistor

Technical data

Impulse voltage:	140 kV
Resistance:	350 Ω
Length/ Height:	743 mm
Weight:	5 kg

Application

For generation of impulse voltages. The resistors determine the rise time of the impulse voltage in lightning and switching impulse voltage generation.



HV9123 Wave Tail Resistor

Technical data

Impulse voltage:	140 kV
Resistance:	2800 Ω
Length/ Height:	743 mm
Weight:	5 kg

Application

For generation of impulse voltages. The resistors determine the time to half value of the impulse voltage in lightning and switching impulse voltage generation.



HV9127 Load Resistor

Can be used as charging resistor in impulse generators or loading resistors in HVDC Experiment.

Resistance:	2.5 Mohm
Length/ Height:	743 mm
Weight:	4.5 kg



HV9124 Insulating Rod

Technical data

AC voltage:	100 kV
DC and impulse voltage:	140 kV
Length/ Height:	743 mm
Weight:	1.5 kg

Application

Insulating component



HV9125 Sphere Gap

Technical data

Impulse voltage:	140 kV
Spehere Diameter:	100 mm
Max. gap settings:	80 mm
With gap settings indicator	
Length/ Height:	743 mm
Weight:	7 kg

Application

For impulse voltage generation, for pre-settings of Impulse voltage peak.



HV9126-D Drive for Sphere Gap

Technical data

Supply voltage:	24V DC
Dimensions:	85x115x185 mm
Weight:	1.9 kg

Application

Remote control of Shere Gap size. Mounted underneath the Sphere Gap and connected by drive shaft.



HV9140 Electrode 300

Technical data

Diameter: 800 mm
 Height: 300 mm
 Weight: 12 kg

Application

Top electrode to be placed on the top transformer in 3-stage AC-Set-up. Manufactured in polished Aluminum.

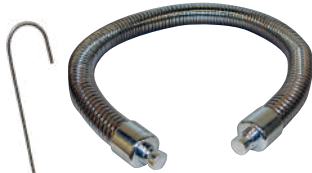

HV9106 HV Connection

Length: approx 1.5 m

HV9106-3 HV Connection

Length: approx 2 m

Application

Flexible metal connection with connector for the test transformer and connecting cup. For connection of multi-stage AC voltage test equipment with the test transformer.



HV9114 Earthing Switch, Electrically Operated

Technical data

Impulse voltage: 140 kV
 DC voltage: 140 kV
 Service voltage: 24 V, 50/60 Hz
 Dim. (excl. earth rod): 230x115x160 mm
 Weight: 8 kg

Application

For automatic safety earthing of the high voltage construction kit when de-energized.



HV9138 Electrode

Technical data

Diameter: 300 mm
 Weight: 1 kg

Application

Serves as termination in conjunction with grounding switch for safety grounding. Also serves as corona free electrode.



HV9107 Discharge Rod

Technical data

Length: 2.5 m
 Weight: 2.5 kg

Application

For manual discharging of HV components.



HV9109 Connecting Cup, Aluminum

Technical data

Dimension: $\varnothing 115 \times h 86 \text{ mm}$
 Weight: 2.2 kg

Application

Conductive Element: Four elements can be inserted in horizontal position and two in vertical position.



HV9110 Floor Pedestal, Aluminum

Technical data

Dimension: 200 x 200 x 80 mm
 Weight: 2 kg

Application

Conductive Element: For mounting up to four spacer bars horizontally and supporting one component vertically.



HV9108 Connecting Rod, Aluminum

Technical data

Length: 743 mm
 Weight: 1 kg

Application

Conductive connection element.



HV9119 Spacer Tube, Aluminum

Technical data

Length: 718 mm
 Weight: 1 kg

Application

Mechanical and electrical connection on ground level when inserted into floor pedestal.



HV9142 Two Stage Measuring Capacitor

Technical data

AC voltages: 200 kV
 Capacitance: 100 pF

Height: approx 1.70 m
 Weight: approx 75 kg

Application

High voltage divider capacitor for measurement of AC voltages.



HV9143 Three Stage Measuring Capacitor

Technical data

AC voltages: 300 kV
 Capacitance: 100 pF

Height: 2.30 m
 Weight: approx 125 kg

Application

High voltage divider capacitor for measurement of AC voltages.



HV9146 Coupling Capacitor

Technical data

Rated Voltage: 120 kV
 Capacitance: 1 nF
 Partial Discharge: 5 pC

Height: 1.30 m
 Weight: 56 kg

Application

High voltage coupling capacitor to be used mainly for partial discharge measurements in HV testing.

Terco reserves the right to make changes in the design and modifications or improvements of the products at any time without incurring any obligations

Test Apparatus

HV9134 Vessel for Vacuum and Pressure.

For the determination of the flashover voltage of electrode arrangements as a function of vacuum and pressure. The vessel consists of a Plexiglass cylinder fixed with top and bottom flanges which are connected to high voltage and ground potential respectively.

The bottom cover is equipped with the necessary accessories like inlet valve, outlet valve and measuring gauges for pressure and vacuum. The earthing terminal is provided in the bottom pedestal. The 50 mm sphere electrodes are mounted as shown in the HV9134 picture.

Technical data

AC Voltage	100kV
DC Impulse Voltage	140 kV
Max. operating pressure (abs):	0-6 bar
Height	approx 800 mm
Weight	12 kg

The vessel is delivered with the following different electrodes:

- Sphere electrodes 20 and 50 mm
- Needle electrodes
- Rod electrodes
- Flat electrodes
- Case for all parts

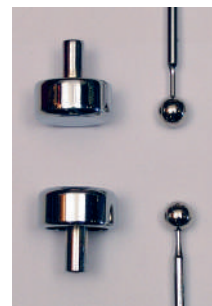

*Flat and 20 mm
Sphere Electrodes*



*Needle and
Rod Electrodes*



HV9134-A1 Vacuum Pump

The Vacuum Pump HV9134-A1 is designed for pumping of inert gases in the range of rough vacuum, between atmospheric pressure and ultimate pressure of the pump.

Technical Data

Nominal pumping speed	m3/h	50 Hz	60 Hz
Ultimate partial pressure without gas ballast	mbar	11	13
Motor power	kW	<1,5	< 1,5
Dim: 320 x 270 x 220 mm		0,55	0,65
Weight with mineral oil	kg	20	20



HV9134-A2 Compressor

This is a piston type oil-lubricated compressor driven by a single phase electric motor and of fully automatic design. The compressor works silently and vibration-free.

General Data:

Power supply:	220-240V, 50-60Hz 1-ph
Capacity:	26 l/min at 8 bar
Max. working pressure:	8 bar
Dimension:	380 x 380 x height 470 mm
Weight:	22 kg





HV9133 Measuring Spark Gap

Sphere Gap is a standard measuring device for flash over voltage using various electrode arrangements. It consists of supporting arrangements like remote and hand operated gear, for easy gap setting.

HV9133 can also be used as spark gap by mounting HV9132 Electronic Trigger Sphere.

10 m cable for remote spark gap control via the HV9104 Control Desk included together with 5 different electrodes.

Technical data:

AC, DC, IMP Voltage:	0-100 kV
Range:	1-70 mm
Power supply:	24V DC
Height	approx. 800 mm
Weight	18 kg

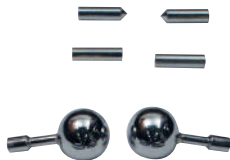

HV9133-EL Sphere Electrode

Sphere Electrodes:	50 and 100 mm diam.
Rod Electrode:	20 mm diam.
Needle Electrode	
Flat Electrode	



The 100 mm sphere electrodes are mounted on the HV9133 above. All electrodes come in a specially fitted protective case.



HV9135 Corona Cage

The Corona Cage is inserted into the VVP (Vessel for Vacuum and Pressure) for determination of the partial discharge intensity as a function of the wire diameter and the voltage.

Measurement can be done with or without vacuum or pressure by means of a Micro meter and an Oscilloscope.

Technical data:

AC voltage:	20 kV
Weight:	1.5 kg

Picture "a" shows HV9135 Corona Cage.

Picture "b" shows HV9135 mounted in to HV9134, vessel for vacum pressure.

HV9137 Oil Testing Cup

The Oil Testing Cup is used to measure breakdown of insulating oils. It has special spherical electrodes with a preset gap setting of 2.5 mm. Measuring Rod is included.

Dimension: 140x100x110 mm

Weight: 0.5 kg

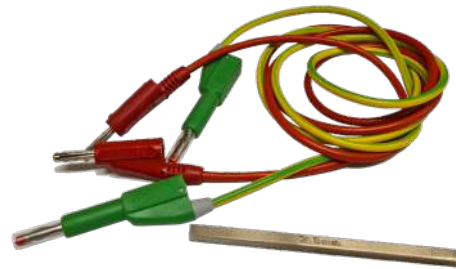

Connection leads and electrode distance measuring tool that follows IEC 60156 standards is included.

The oil test cup is an arrangement for measuring breakdown voltage of insulating oils. The preset gap between the electrodes is $2.5 \text{ mm} \pm 0.05 \text{ mm}$. This is valid for transformer insulating oil according to IEC 60156 (Determination of breakdown voltage for insulating liquids) and is set with the included 2.5 mm spacer. To perform a test, required quantity of oil is poured inside the cup, till the electrodes are totally immersed in oil. High voltage is then applied at one electrode (the other electrode is earthed) until breakdown occurs. The measured voltage is then the breakdown voltage for the insulating oil.





HV9170 Test Object Package



Insulators are crucial components of all HV transmissions lines. It is thus very important to understand how insulators are selected and dimensioned.

The dimensioning of Insulators is critical in terms of electrical, mechanical and environmental stress. TERCO has for this package selected three typical high voltage Insulators.

They come in a sturdy Aluminum case complete with all the necessary connections and a complete experiment manual.

Type of insulator	HV9171 Glas disc insulator (2 pc)	HV9172 Ceramic line post insulator	HV9173 Composite line post insulator
Characteristic			
Rated system voltage (kV)	12	24	24
Dry flashover voltage (kV)	80	80	110
Wet flashover voltage (kV)	50	60	95
Impulse flashover Pos/Neg (kV)	125/130	130/155	150/170
Low puncture voltage (kV)	130	-	-
Leakage distance (mm)	303	356	550
Dry arc distance (mm)	210	180	218
Height (mm)	146	226	322
Diameter (mm)	255	100	100
Weight (kg)	3.5	5.1	4.2

Above insulations are included in HV9170 package

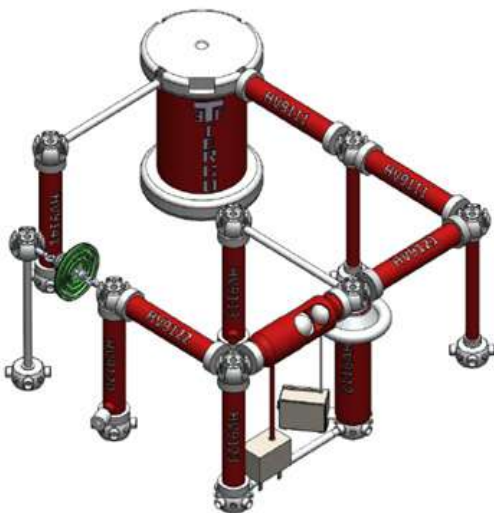

Experiment 1. Disruptive discharge voltage tests with alternating current.

Experiment 2. Disruptive discharge voltage tests with direct current.

Experiment 3. Lightning impulse disruptive discharge test.

Accessories

HV9191 Component Stand

Sturdy welded construction on four wheels for easy storage of HV components can hold 8 cylindric components and 16 connecting cups / Floor pedestal.

Dim.: 745 x 560 x1145 mm
Weight: 25 kg



HV9105-CON Cascade Connection Set

To be used to couple 3 pcs HV9105 Transformers in a cascade position including base plate with four wheels.



HV9160-PD Partial Discharge System

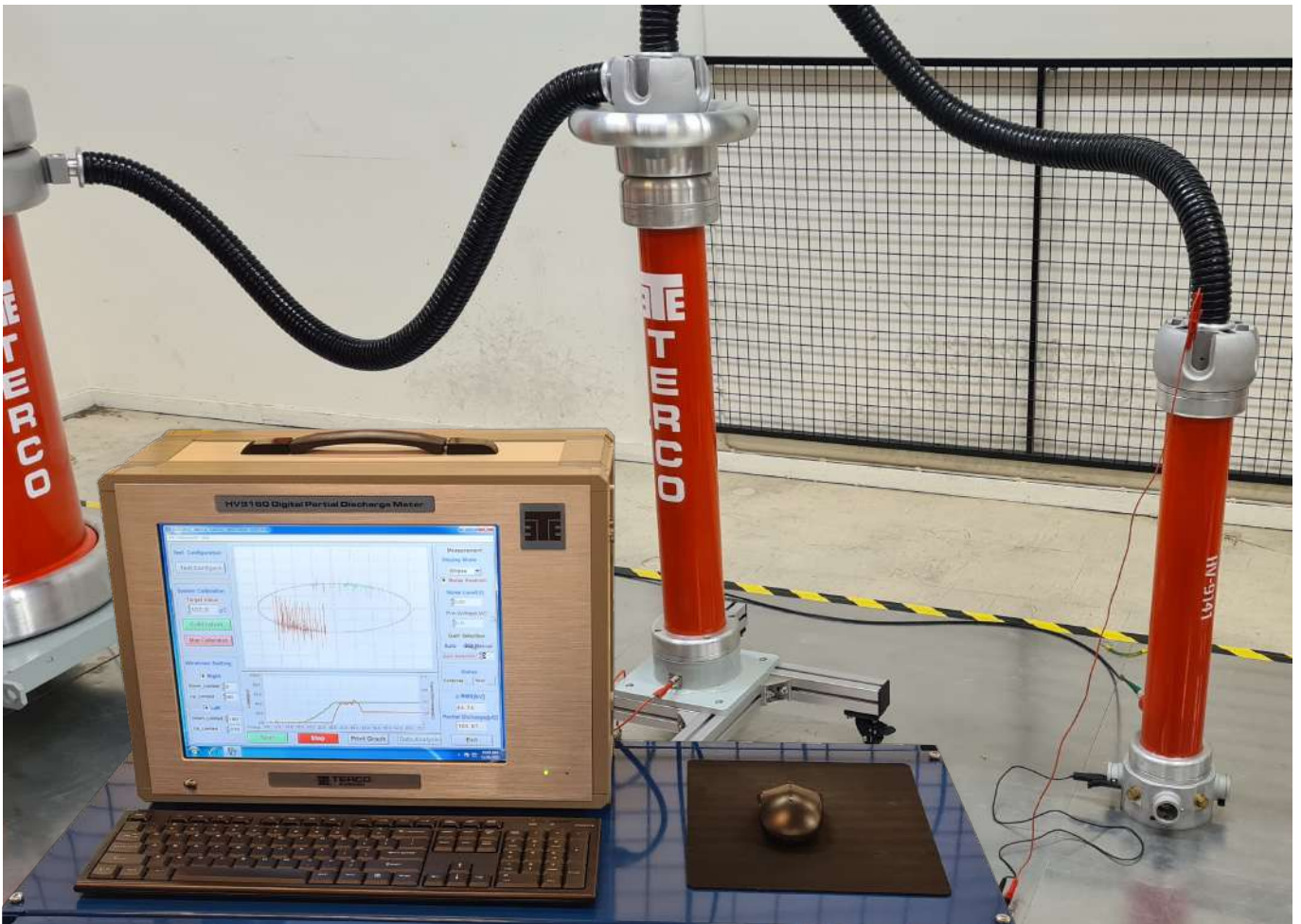

Technical Description

TERCO HV9160-PD System is the ideal solution for pass/fail partial discharge testing and meets all IEC and IEEE/ANSI standards for PD testing. It's designed to help you modernize your facility at an affordable price, and it's simple to operate.

HV9160-PD System provides the most intuitive and easiest to use operator interface of any available digital PD testing system. Data analysis is fast, easy and requires little training. Its Windows™-based software allows flexible test recording and data export to Word™, Excel™ and other Windows programs. In addition, only HV9160 provides a completely open architecture.

Easy operation

HV9160 PD System uses Windows operating system and an intuitive control and display panel to allow even inexperienced operators to learn quickly with minimal training. All the features such as real-time bipolar pulse display, display graticules, analog readout, simple adjustment, etc., are built-in. In addition, advanced features such as higher accuracy, automated calibration, data analysis, and customized test recording, are standard.

HV9160-PD System can automate your entire PD testing process. Automated calibration simplifies setup. HV9160-PD can work with any HV source. When interfaced with other suitably equipped control systems for AC sources, control of the entire HV source is provided through the HV9160 PD System and test reports contain complete data on all aspects of the test..

HV9160-PD System has been designed with an open hardware and software architecture that eliminates obsolescence. Not only is this PD measuring instrument the most advanced instrument available, it will stay the most advanced well into the future, and adapting new emerging technology to meet changing testing needs. Microsoft ActiveX technology even allows third party developers to write new data analysis for the whole system.



Advanced Analysis Capability

HV9160-PD possesses the most flexible analysis tools of any digital partial discharge detector. Pulse capture can be achieved against phase or time.

There is full control over gating (vertical and horizontal) of pulses so that the effects of interference can be reduced. Optional software and hardware modules add capability for partial discharge site location, external pulse discrimination, noise suppression, three dimensional plots, and discharge pattern fingerprinting.

HV9160-PD System provides a color, bipolar pulse display that is easy to read and interpret. Calibration pulses and zero markers are clearly displayed, and pulses are easily viewed. Display update is fast (25 times/second).



HV9160-PD System allows you to automate your calibration. Just type in the value and HV9160-PD System does the rest. Manual calibration (as with conventional, analog detectors) can also be performed.

The TERCO HV9160-PD System provides complete control over horizontal and vertical gating (windowing) thereby suppressing noise!

Applications

- Power Cables
- Distribution and Power Transformers
- MV and HV Switchgear
- Power Circuit Breakers
- Gas Insulated Switchgear
- Bushings
- Shunt Reactors
- Potential Transformers and Current Transformers
- Power Factor Correction Capacitors
- Line Insulator Products
- Lightning Arrestors
- High Voltage Laboratories
- HV Components
- Insulating Materials of All Types

Several standard test records are provided. Data can be inserted into any other Windows application for custom report generation.

Applicable Standards

IEC-60060 Part 1 & Part 2; IEC-60270; IEC-885-2 and IEC-885-3; IEEE Std. 4, 1995

Use Conditions

Operating Temp Range: 0°C to 40°C
 Storage Temp Range: -10°C to 75 °C
 Humidity Range: 95% non-condensing
 Ethernet Port: Isolated 10 BaseT (note: optically isolated cable recommended)

Technical Specification Amplifier

Gain: 0 dB to 120 dB
 Attenuator Accuracy: 1 %
 Input Impedance: 1MΩ
 System Noise: < 15 μV referred to input on highest gain range

Filters

High Pass: -10, 20,30, 50, 80 kHz
 Low Pass: -100, 200, 300,400, 500 kHz

PD Measurement

Range: 0.1 -10 000 000 pC
 PD Meter Resolution: 0.2 %
 Linearity Error: < 1 %

Voltage measurement

Input Voltage 0-50V: voltage measuring range 0-120 kV
 Linearity (10-100% FS): < 1%
 Resolution: 12 bits

ORDER DETAILS FOR HIGH VOLTAGE LAB AC, DC AND IMPULSE STAGE 1, 2 AND 3

Product no	Description	AC-test			DC-test			Impulse			page
		1	2	3	1	2	3	1	2	3	
Basic Components		No of items for each stage									
HV9104	Control Desk	1	1	1	1	1	1	1	1	1	91
HV9105	Test Transformer 100kV	1	2	3	1	1	1	1	1	1	93
HV9105-CON	Cascade Connection Set		1	1							102
HV9106	High Voltage Connection	1	1								96
HV9106-3	High Voltage Connection			3							96
HV9107	Discharge Rod	1	1	1	1	1	1	1	1	1	96
HV9108	Connecting Rod	1			2	3	3	2	5	8	96
HV9109	Connecting Cup	1	1		3	10	14	9	14	25	96
HV9110	Floor Pedestal	1			3	5	6	8	9	10	96
HV9111	HV Rectifier				2	4	6	2	2	2	94
HV9112	Smoothing Capacitor/Impulse Capacitor				1	3	5	1	2	3	94
HV9113	Measuring Resistor				1	2	3	1	1	1	95
HV9114	Earthing Switch				1	1	1	1	1	1	96
HV9119	Spacer Tube				2	5	7	5	8	10	96
HV9120	Load Capacitor							1	2	3	94
HV9121	Charging Resistors							1	2	3	95
HV9122	Wave Front Resistor							1	2	3	95
HV9123	Wave Tail Resistor							1	2	3	95
HV9124	Insulating Rod				1	9	10	5	5	14	95
HV9125	Sphere Gap							1	2	3	95
HV9126-D	Electrical Drive for Sphere Gap							1	1	1	95
HV9138	Top Electrode				1	12	18	1	1	1	96
HV9139	Electrode 200		1								
HV9140	Electrode 300			1							96
HV9141	Measuring Capacitor/100	1									94
HV9142	Measuring Capacitor/200		1								97
HV9143	Measuring Capacitor/300			1							97
HV9145	Compensating Reactor		1	2							
Measuring and Control Equipment											
HV9130	Low Voltage Divider	1	2	3							94
HV9132	Electronic Trigger Sphere							1	1	1	94
Test Apparatus											
HV9127	Load Resistor				1						95
HV9133	Measuring Spark Gap	1			1			1			99
HV9134	Vessel for Vacuum/ and Pressure	1			1			1			98
HV9135	Corona Cage	1									99
HV9137	Oil Testing Cup	1									100
HV1946	Coupling Capacitor	1									97
HV9160-PD	Partial Discharge Meter	1									103
HV9170	Test Object Package	1	1	1	1	1	1	1	1	1	101
Storage											
HV9191	Component Stand	1	1		1	2	4	2	4	8	102
HV-CAGE 1	Safety Cage for Stage 1										85
HV-Inst	Installation and Training										84

Electrical Installation Laboratory

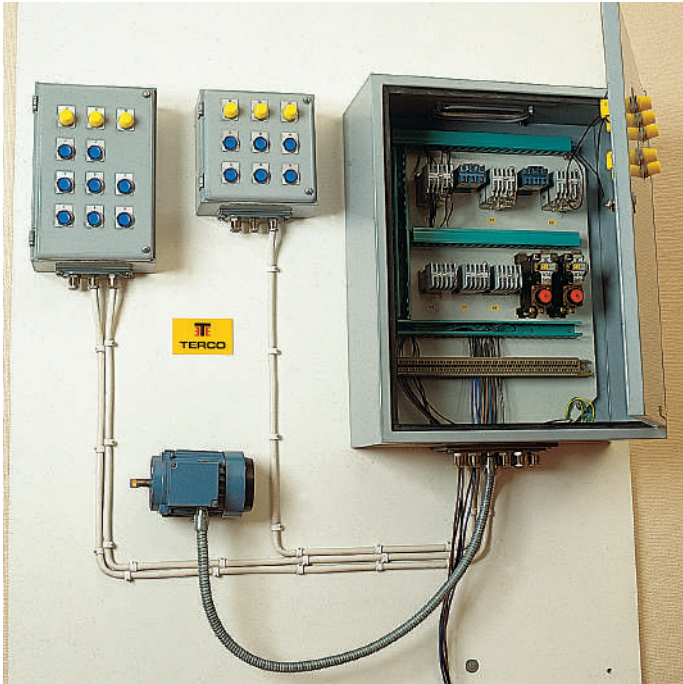

Installation Training

In order to be successful in the training of electrical installation, it is necessary to observe many important details.

These details can vary from place to place depending on local installation regulations, installation systems adopted, trainees background and levels of training.

A few of the points to be considered, which are common to most training situations, are:

- a) Training objectives must be clearly defined before starting any training.
- b) The requirements of the electrical regulations must be observed.
- c) Safety must be an integral part of training.
- d) Course planning and breakdown of actual practical and theoretical projects must be completed.

- e) Material and equipment used must be to the standards, robust to withstand heavy treatment from beginners, compiled in such a way that the training follows a pedagogic sequence and should follow normal installation practice as far as it is possible.
- f) Control and storage of training items must be easy to execute.

The training equipment listed in this brochure has been designed with these points in mind. Each unit is compact, sturdy, possible to use over and over again, and delivered with training instruction manual.



Rack MV1605 with different installation kits.

Installation Training Equipment

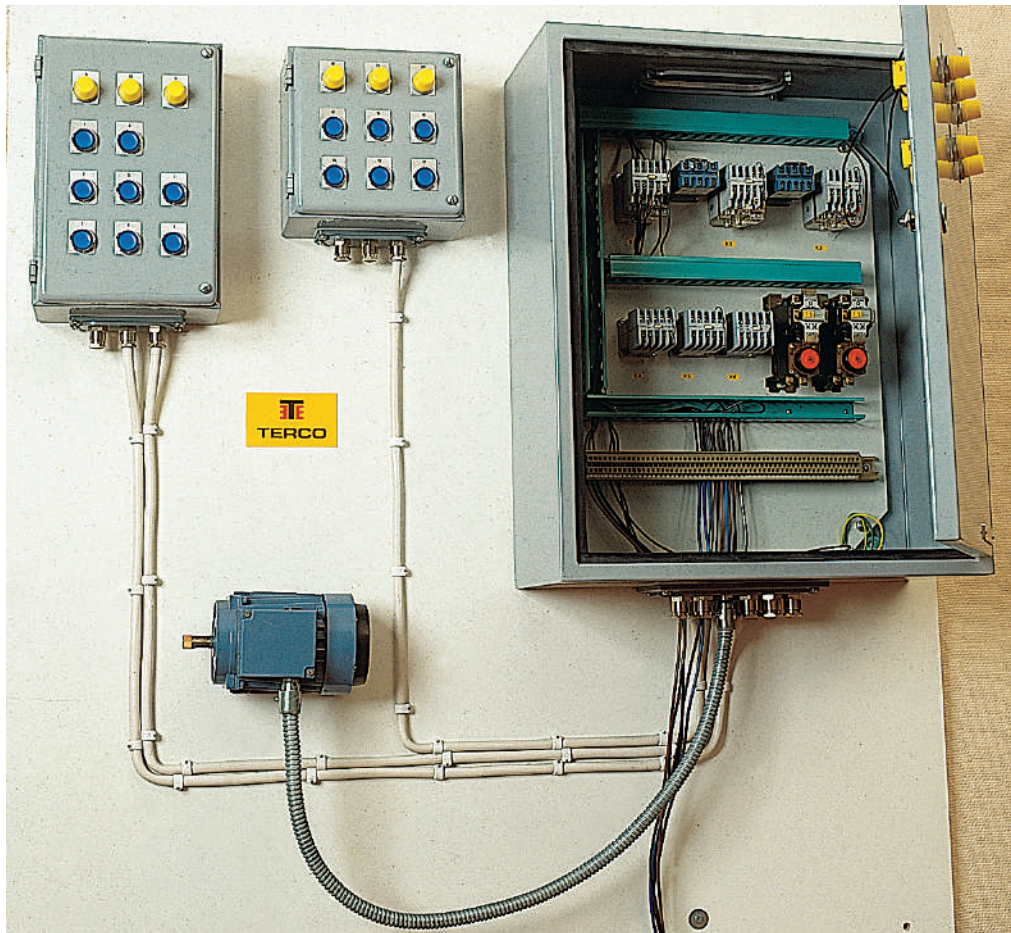

MV1608 Installation Training Equipment

The equipment consists of three units, the equipment cabinet, the control cabinet, and the control desk. The equipment cabinet is fitted with contactors, relays, signal lamps, terminal blocks and wiring channels. The illustration shows the equipment cabinet interconnected with the control cabinet and control desk having pushbuttons and signal lamps.

With the aid of various types of wiring diagrams, circuit diagrams and operating instructions, the student can install and test run various systems and practice in meter reading and measurement.

Detailed instructions for 14 exercises are supplied with the equipment, order no. MV1608-012. The motor and all cables shown on the picture are not included in the order no.

General Data

Three-phase voltage 380-415 V, 50-60 Hz
Control voltage 220-240 V, 50-60 Hz

Control Cabinet	215 x 120 x 215 mm	4 kg
Equipment Cabinet	540 x 240 x 660 mm	30 kg
Control Desk	215 x 120 x 325 mm	5 kg

Additional Equipment

MV1628 Induction Motor 3-phase

Power	0.37 kW
Speed	1400 rpm 50 Hz, 1680 rpm 60 Hz
Current	1.3 A (Star 380-415 V) 2.25 A (Delta 220-240 V)

MV1680 Assembly Kit

25 m	Cable EKK-S 4-core and earth, 1.5 mm ²
10 m	Cable EKK-S 6-core and earth, 1.5 mm ²
10 m	Cable RK, PVC single, 1.5 mm ² yellow-green
100 m	Cable RK, PVC single, 1.5 mm ² black
1 set	Cable markers
2 m	Flexible conduit, PVC-covered
2 pcs	Glands for flexible conduit
100 pcs	Fixing clips

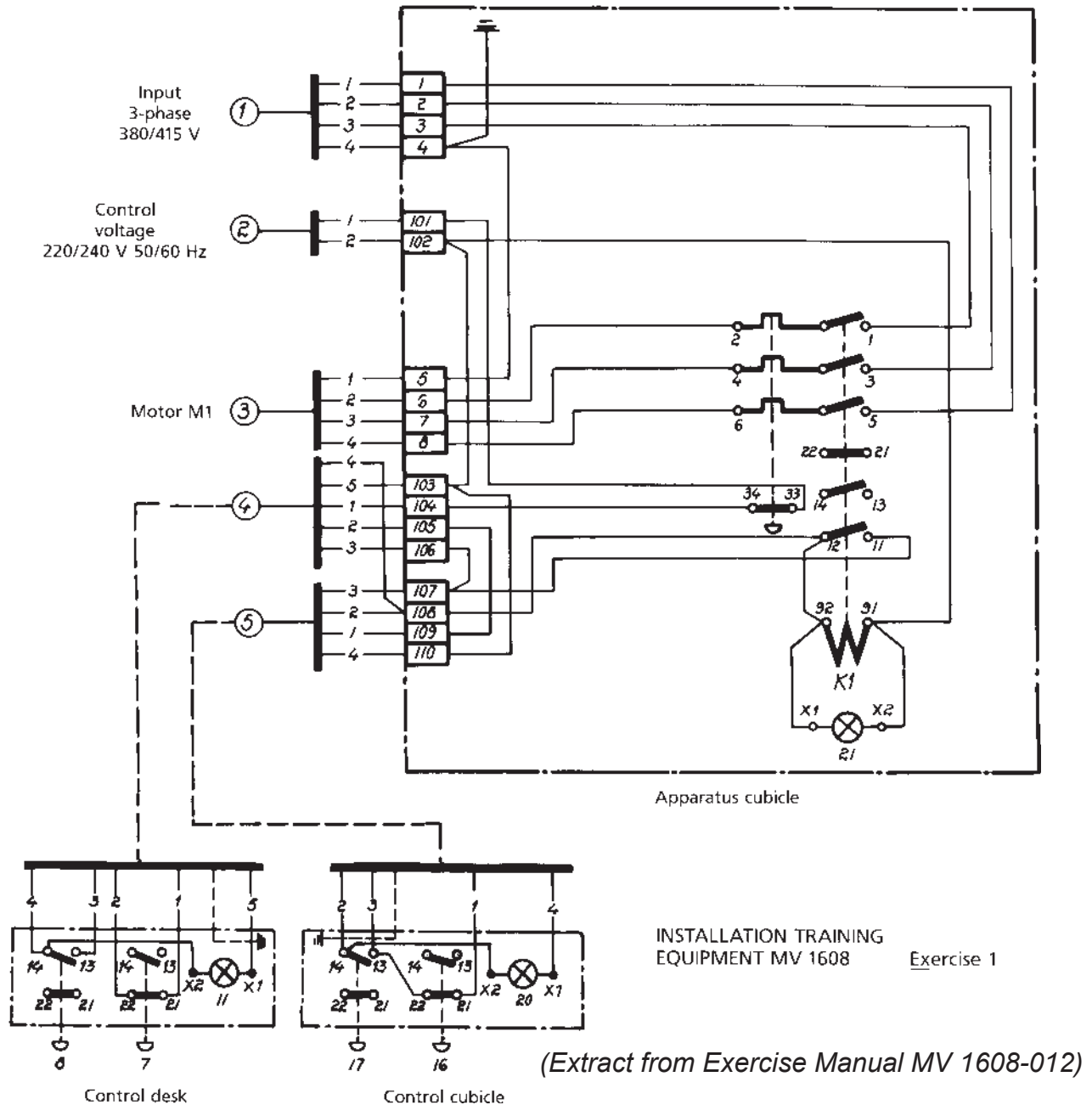

Exercise 1

1. The motor M1 shall be controlled and protected by the direct-on-line starter K1. The control shall partly be done from the control cubicle M, partly from the control desk P. When the motor M1 is started, signal lamps in the apparatus cubicle, in the control cubicle and on the control desk shall light.
2. The apparatus shall be connected according to the wiring diagram.

Student's task

Mounting of the apparatus and connection according to the wiring diagram.

3. After testing and control of the function, the following currents shall be measured:
 - a) Current through lamp no. 11.

b) Current through the coil for the contactor K1.

After the above stated measurements are completed, the student shall note to which of the terminals the instruments have been connected and also, if other steps must be taken to get the desired measurement values, to be noted as well.

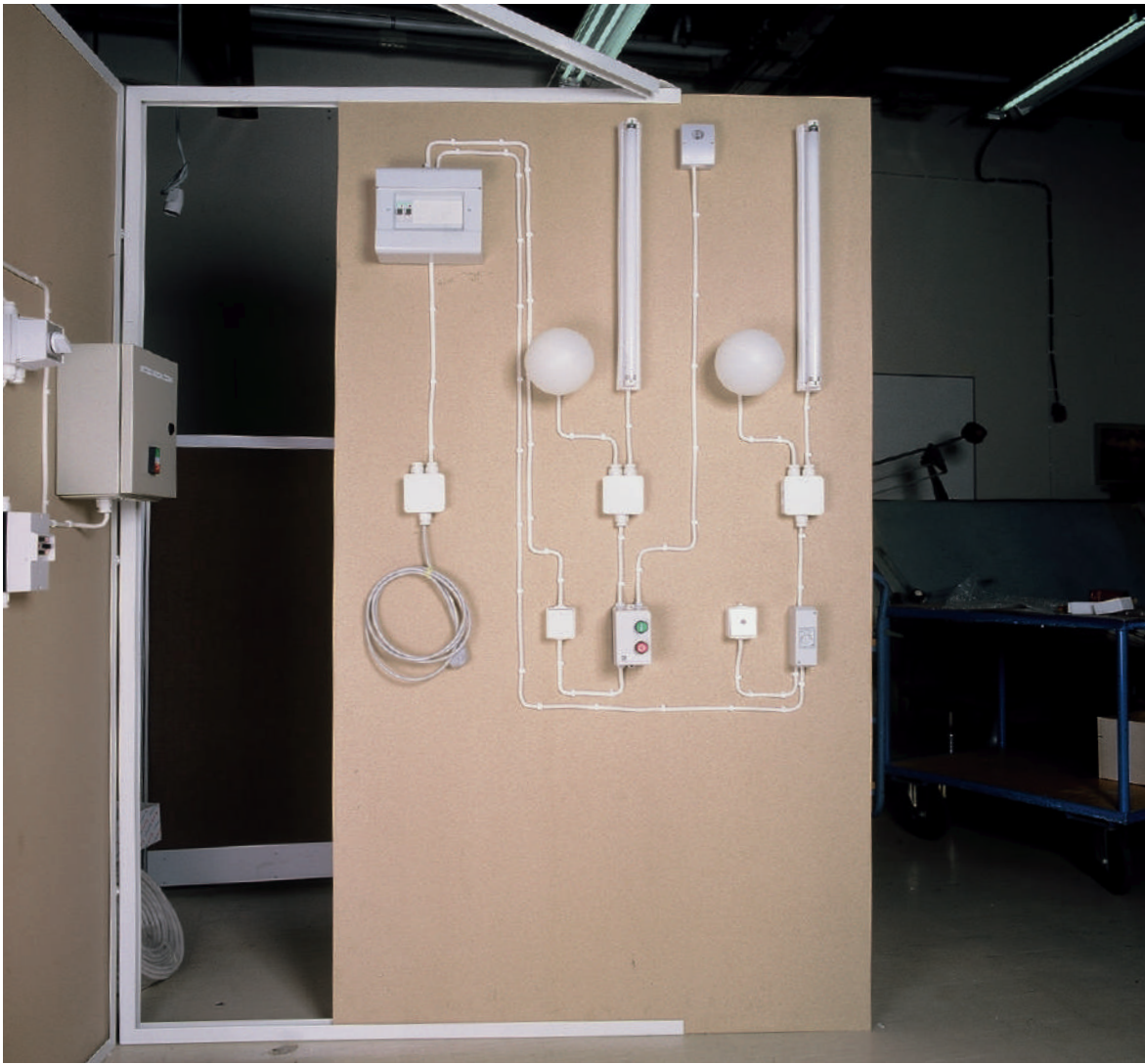

Electrical Installation Laboratory



Electrical Safety System and Installation Protection

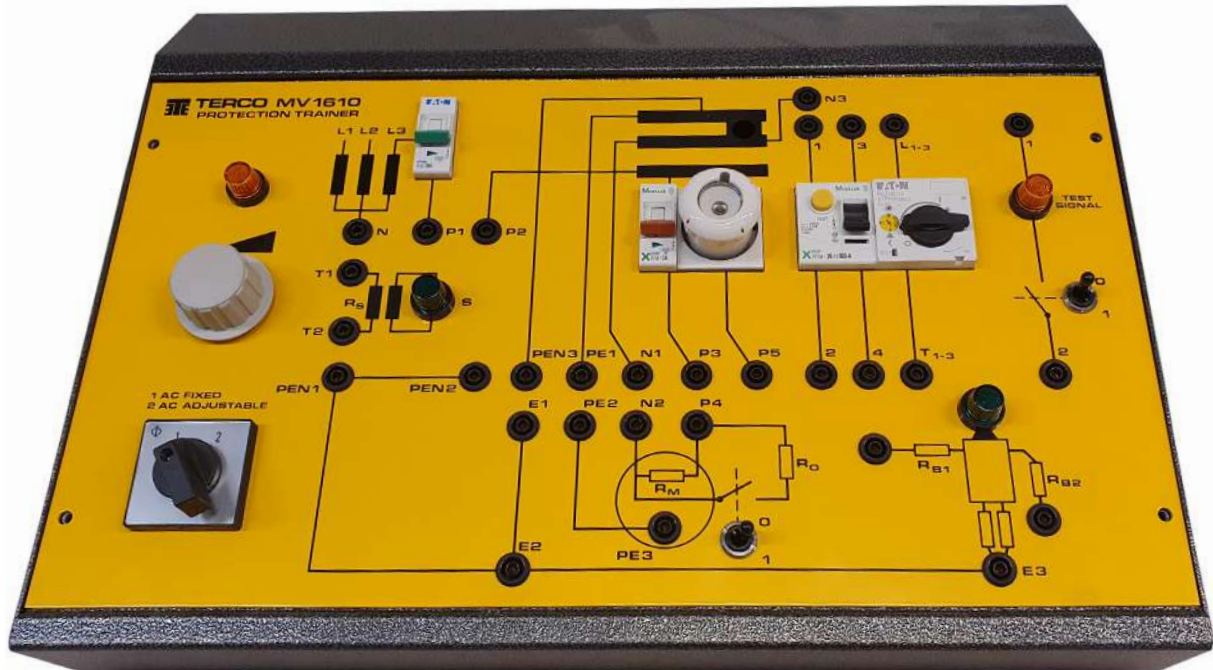

MV1610-2 Protection Trainer

Designed for study of dangers arising in electrical installations and equipment used in the protection against such dangers. The equipment is complete and comprises also earth fault circuit breaker and motor circuit breaker.

The Protection Trainer consists of:

- Directly earthed system
- Indirectly earthed system
- Network forms
- Installation measurements
- Transformer
- Distribution board
- Diazed fuse
- Micro circuit breaker
- Motor circuit breaker
- Earth leakage circuit breaker
- Model for human body
- Model for electrical motor
- Resistances for earthing
- Conductors
- Protected earth
- Signal lamp
- Switch

Additional equipment as below is required to complete the experiments:

- | | |
|------------|--|
| MV 1810-HF | Laboratory leads, black (Set of 10) |
| MV 1809-HF | Laboratory leads, blue (Set of 10) |
| MV 1811-HF | Laboratory leads, green/yellow (Set of 10) |
| | Multimeter (5 pcs) |
| | Stop watch (1 pc) |

General Data

- | | |
|--------------|---------------------------------|
| Power supply | 220-240 V, 1-phase AC, 50-60 Hz |
| Dimensions | 485 x 200 x 315 mm |
| Weight | 15 kg |

Electrical Installation Kits

Electrical distribution systems and equipment must be correctly installed and maintained in accordance with accepted electrical engineering standards and practices, as stipulated in the publications of the International Electrotechnical Commission (IEC).

All of our products described in this manual are manufactured and tested in accordance with the relevant IEC standards.

Each kit is complete with cables, clips, screws, joint boxes, plugs and necessary electrical accessories ready to install. Installation instruction and circuit diagrams are prepared in pedagogical sequence thus ensuring easy installation and correct function. These training kits are designed to be installed on assembly boards which are placed in special frames. The boards can be removed from the frames and stored in a rack built for this purpose.

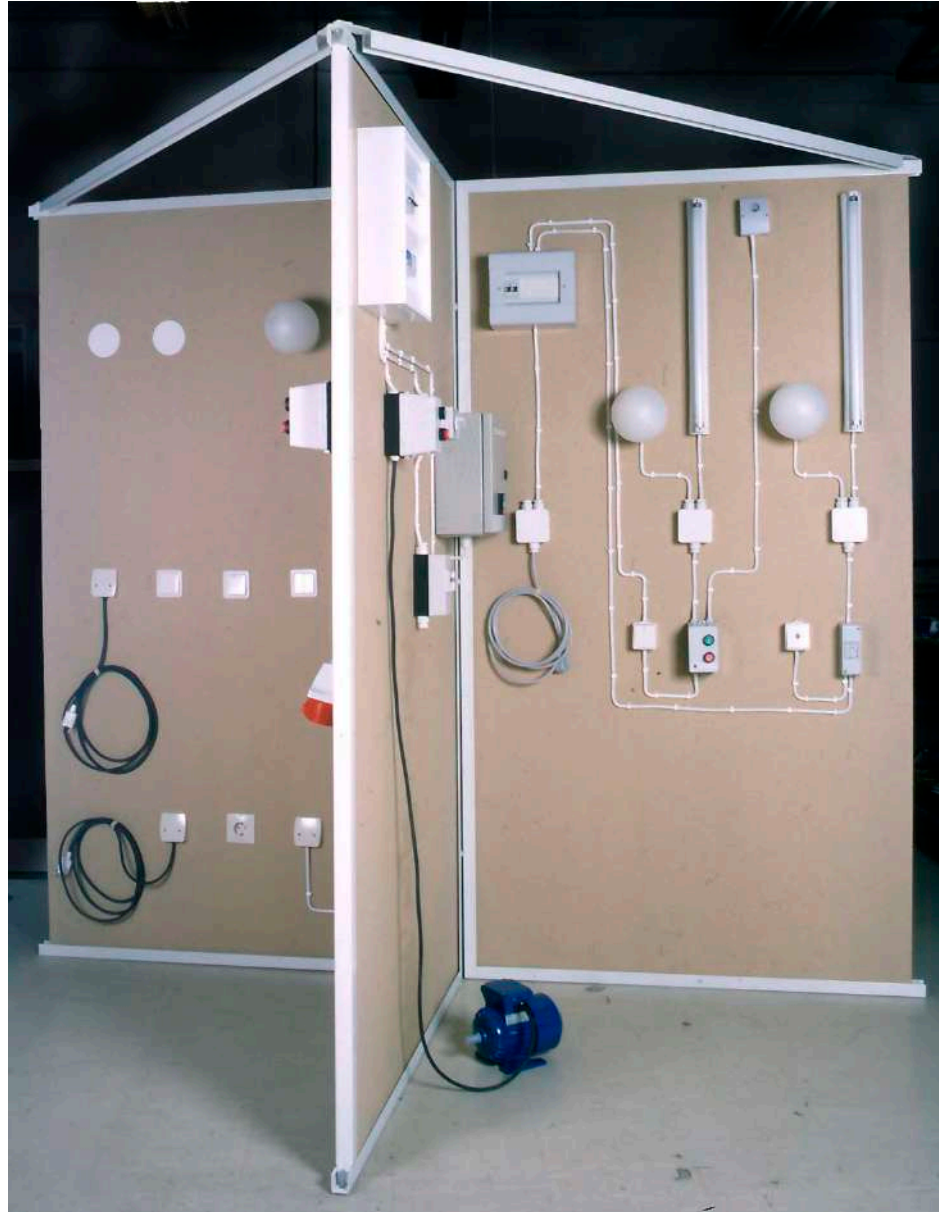

MV1605 Assembly Frame

Easily assembled and disassembled. Can be free standing or fixed to the floor or to a work bench. Plasterboard, chipboard or wood can be fitted to this frame providing total thickness is not more than 30 mm. The T-shaped assembly takes 3 boards each of the area 1200 x 2200 mm.

Weight 30 kg

MV1606 Assembly Boards

Chipboard	Set of 3
Dimensions	1200 x 2200 x 22 mm (each board)
Weight	114 kg (3 pcs)

Terco reserves the right to make changes in the design and modifications or improvements of the products at any time without incurring any obligations

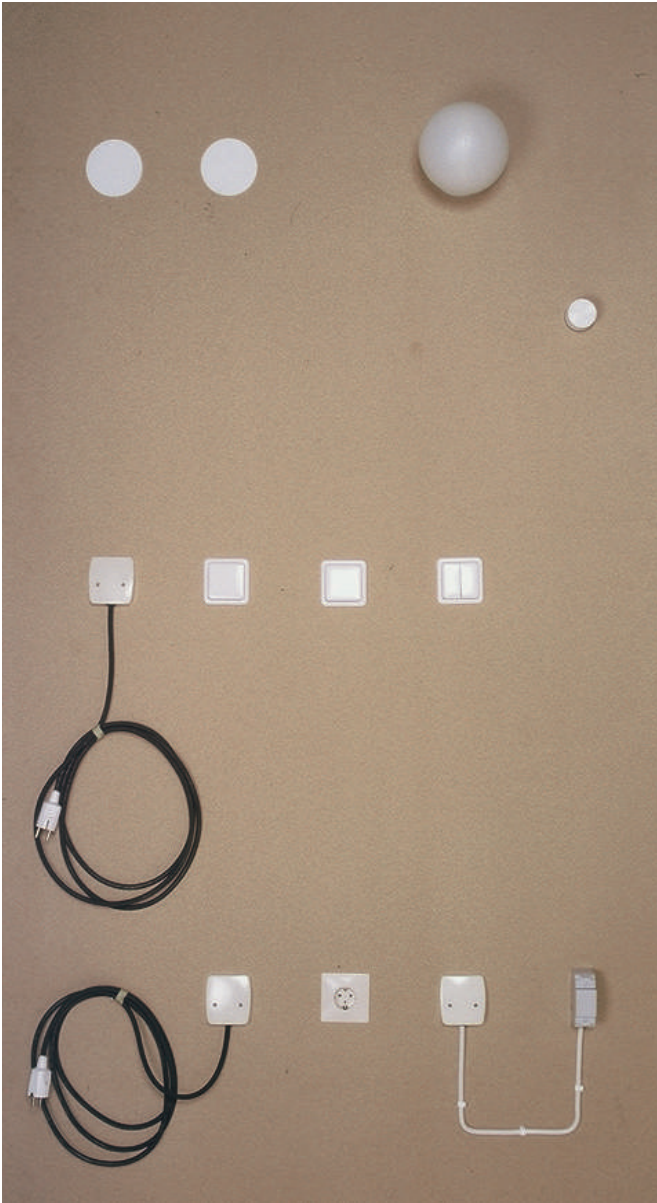

MV1600 PVC Conduit Installation Kit

Installation practice using PVC conduit in concealed conditions, complimented with different wiring circuits including

intermediate switching and socket circuits.

The kit consists of:

10 m	Cable REV 3x1.5 mm sq
100 m	Conduit cable FK 1 x 1.5 mm sq, white
100 m	Conduit cable FK 1 x 1.5 mm sq, black
100 m	Conduit cable FK 1 x 1.5 mm sq, blue
100 m	Conduit cable FK 1 x 1.5 mm sq, yellow/green
4 pcs	Junction box
9 pcs	Terminal mounting box
4 pcs	Blanking plates, diameter 100 mm
100 pcs	Cable connectors
50 m	PVC tubing flexible, approx. 15 mm diameter
1 pc	Earth plug
2 pcs	Switch, one way
1 pc	Switch, one way, double
2 pcs	Switch, two way (stair case)
1 pc	Switch, intermediate
3 pcs	Wall socket, one way, with earth
100 pcs	Wood screws (4.15 x 19)
30 pcs	Wood screws (for mounting boxes)
3 pcs	Lamp holder, complete
5 pcs	Bulbs
1 pc	Plastic bin
1 pc	Hole cutter T 70 (diameter 74 mm)
1 pc	Hole cutter T 80 (diameter 84 mm)
1 pc	Set of drills for wood
1 pc	Draw spring

Some of the electrical components change design almost every year, so there can be changes in the specification above.

Complete with:

- Installation instruction manual incl. Installation plan with wiring diagram.
- Components/material box.

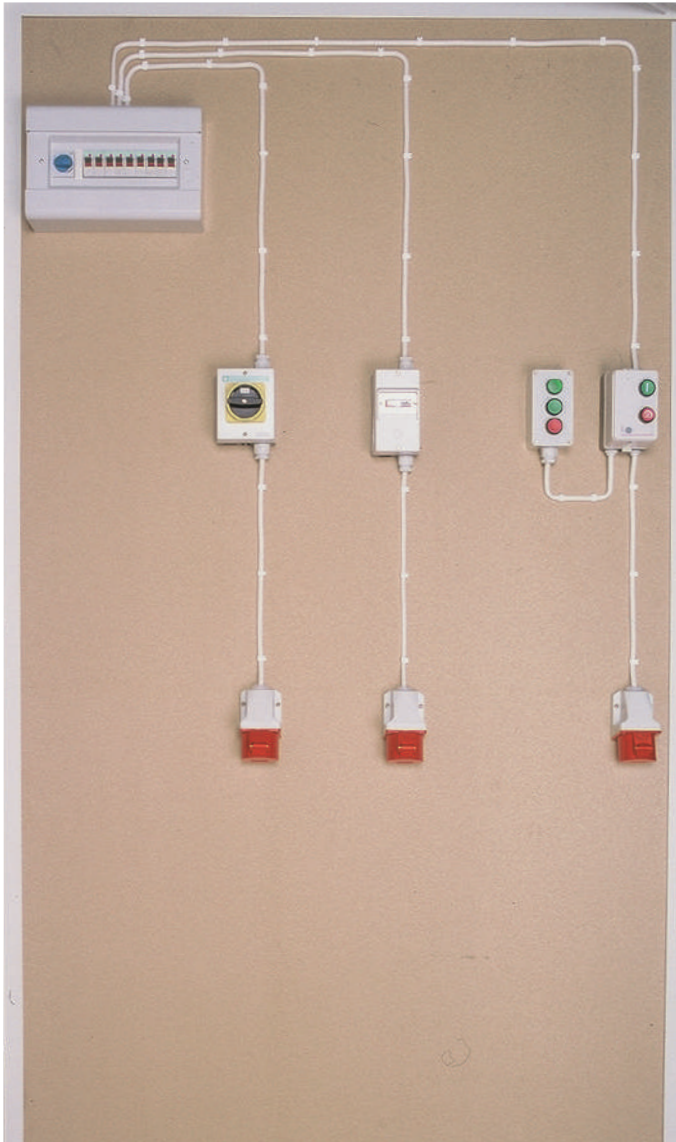

MV1601 Installation Kit for Surface Wiring

To be used for developing skills in clipping, bending and setting of surface mounted wires and cables, making circuit

connections from a fuse experiment panel to single and three phase outlets, circuit breakers, controllers, etc.

The kit consists of:

- 1 pc Distribution panel, complete with MCB
10 A 1-pole (9 MCB's)
- 1 pc Main switch
- 1 pc Motor starter / circuit breaker with contactor
and overload relay
- 1 pc Push button control box
- 1 pc Safety switch
- 3 pcs 3-phase outlets
- 1 pc Direct-on-line starter (manual)
- 100 m Cable EKK 5 x 1.5 mm sq.
- 200 pcs Clips TC 10-14
- 100 pcs Wood screws (4 x 16)
- 100 pcs Wood screws (4 x 24)
- 1 pc Plastic bin

Some of the electrical components change design almost every year, so there can be changes in the specification above.

Complete with:

- Installation instruction manual incl. Installation plan with wiring diagram.
- Components/material box.

Terco reserves the right to make changes in the design and modifications or improvements of the products at any time without incurring any obligations

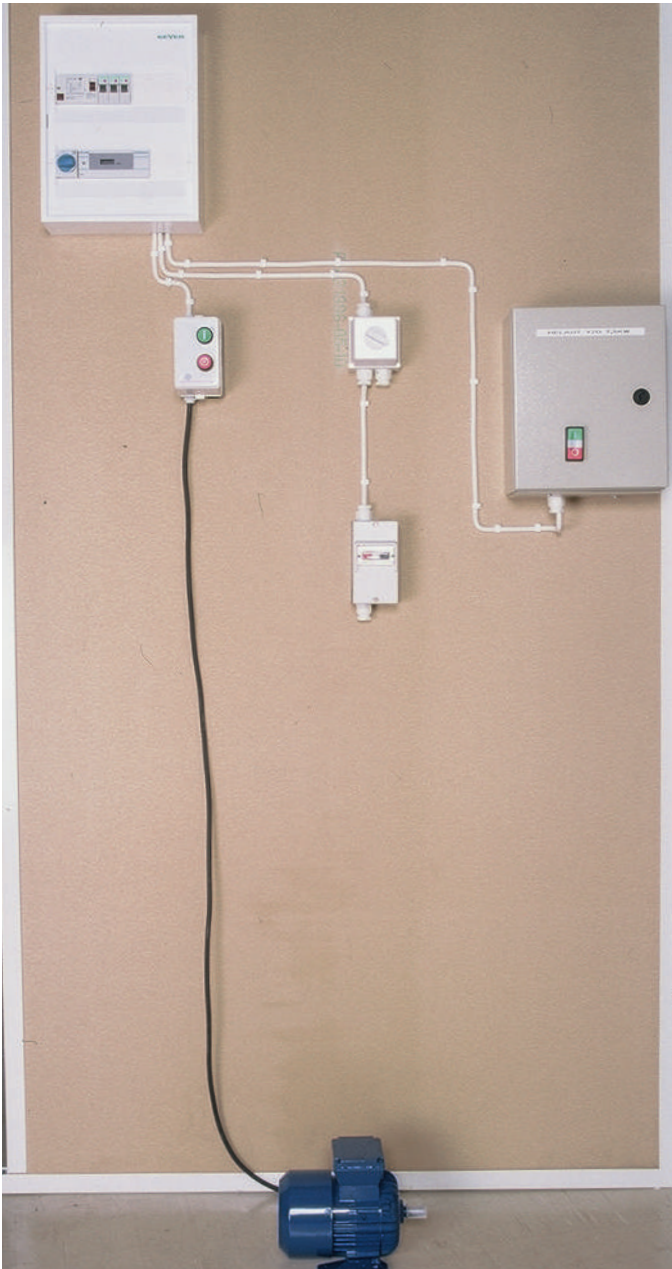

MV1603 Three-phase Motor Wiring Kit

To be used for practical exercise in realistic full size wiring of industrial type of motor controls in accordance with wiring standards.

A three-phase motor is connected to the mains supply via a starter, fuseboard, earth leakage circuit breaker and kWh meter. PVC surface cable is used throughout except for the connection between the motor and terminal box where flexible conduit PVC single cable is used. Direct on line, manual, star delta and automatic star delta starting can be connected into the circuit. Isolated earthing is necessary on the motor circuit for correct operation of the ELCB.

The kit consists of:

- 1 pc 3-phase AC motor
- 1 pc Distribution panel complete with three MCB 10 A 1-pole and main switch
- 1 pc kWh-meter, 3-phase,
- 1 pc Earth leakage protection device
- 1 pc Motor starter / circuit breaker with contactor and overload relay
- 1 pc Direct-on-line starter (manual)
- 1 pc Manual Y / D starter
- 1 pc Automatic Y / D starter,
- 100 m Cable EKK 5 x 1.5 mm sq.
- 200 pcs Clips TC 10-14
- 100 pcs Wood screws (4 x 16)
- 1 pc Plastic bin

Some of the electrical components change design almost every year, so there can be changes in the specification above.

Complete with:

- Installation instruction manual incl. Installation plan with wiring diagram.
- Components/material box.

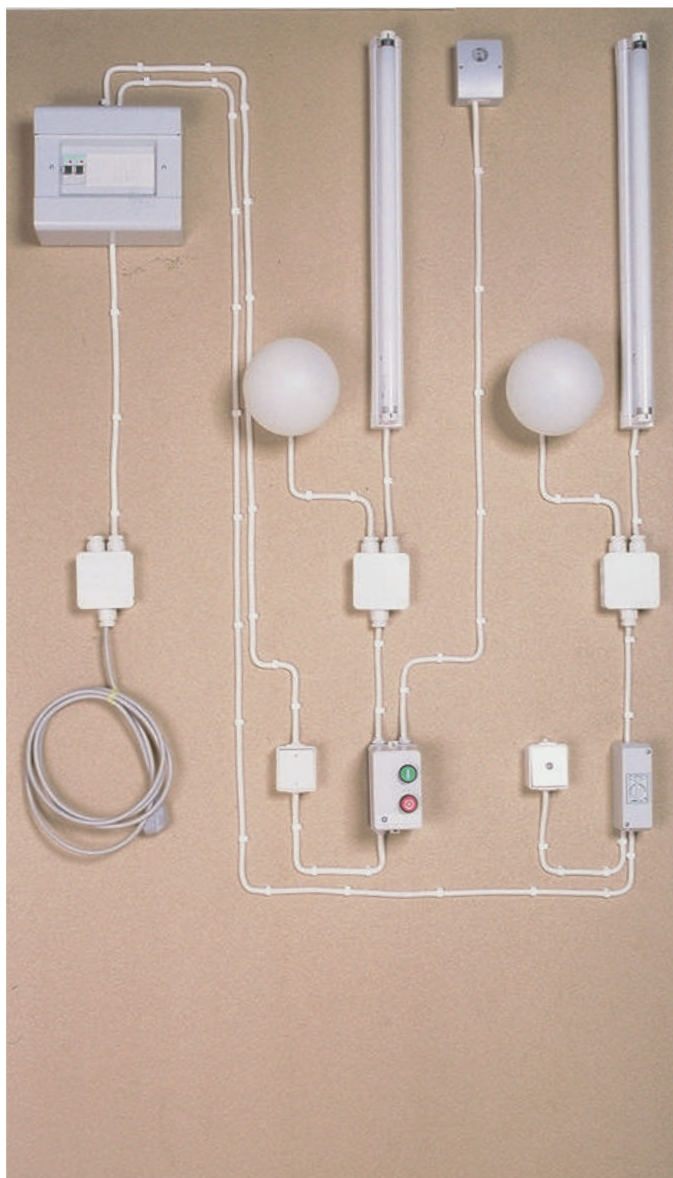

MV1604 Installation Kit for Lighting Wiring

To be used for the student to practice in wiring of lighting control circuits with fluorescent and incandescent lamps.

Two lighting control circuits are incorporated in this module. In circuit No. 1, a fluorescent lamp and an incandescent lamp are controlled by an automatic system using a photo-cell operated relay.

In circuit No. 2, a fluorescent lamp and an incandescent lamp are controlled by a manual pushbutton which operates a timing circuit.

The kit consists of:

- 1 pc Pushbutton box with contactor
- 1 pc Distribution panel with two MCB, 10 A, 1-pole
- 1 pc Photo cell operated relay
- 1 pc Staircase relay
- 1 pc Switch, 2-pole
- 100 m Cable EKK 3 x 1.5 mm sq.
- 25 m Cable EKK 4 x 1.5 mm sq.
- 1 pc Main cable
- 3 pcs Junction box
- 2 pcs Fluorescent lamp holder with choke and starter
- 2 pcs Fluorescent lamps
- 2 pcs Lamp holder, complete
- 2 pcs Bulb
- 500 pcs Clips TC 7-10
- 100 pcs Wood screws (4 x 16)
- 100 pcs Wood screws (4 x 25)
- 1 pc Plastic bin

Some of the electrical components change design almost every year, so there can be changes in the specification above.

Complete with:

- Installation instruction manual incl. Installation plan with wiring diagram.
- Components/material box.



Complete with:

- Installation instruction manual incl. Installation plan with wiring diagram.
- Components/material box.

Some of the electrical components change design almost every year, so there can be changes in the specification above.

MV1665 Residential Wiring Trainer Kit

Residential Wiring Trainer (Kit) for instruction in principles and schematic diagrams of electric wiring in apartments.

The trainer consists of complete modules, representing a typical floor plan of an apartment. The trainer utilises, as much as technically possible, full size electrical components as switches, circuit breakers, receptacles, light fixtures and lamps.

Supply voltage: 24 V AC, 3-phase system from an overload protected power supply, simulating a 220-240 V 3-phase system. The trainer is equipped with an energy meter.

Complete with:

- Set of components to meet residential wiring curriculum requirements.
- Wire package set
- Hand tool set necessary for wiring.
- Student Work Book.
- Laboratory manual describing residential wiring fundamentals such as:
Wiring material components and equipment conductors and overload protection wiring circuits, designing and wiring of a complete electrical system, installation of cables, raceways and trouble-shooting.

The kit consists of:

- | | |
|---------|--------------------------------------|
| 5 m | Cable REV 5 x 2.5 |
| 200 m | Cable FK 1.5, black |
| 200 m | Cable FK 1.5, blue |
| 100 m | Cable FK 1.5, brown |
| 200 m | Cable FK 1.5, yellow/green |
| 1 pc | Junction box |
| 8 pcs | Terminal mounting box |
| 100 pcs | Cable connectors |
| 50 m | PVC tubing flexible |
| 1 pc | Switch, one way, double |
| 5 pcs | Switch, two way (stair case) |
| 1 pc | Wall socket, two way, no earth |
| 100 pcs | Clips, JR 16 |
| 100 pcs | Wood screws (4 x 16) |
| 100 pcs | Wood screws (4 x 30) |
| 1 pc | Distribution Panel |
| 6 pcs | MCB 10 A, 1-pole |
| 1 pc | 3-ph PERILEX socket |
| 1 pc | Wall socket |
| 1 pc | Wall socket, Stromfors |
| 6 pcs | Bulbs, 24 V, 60 W |
| 6 pcs | Lamp holder, porcelain |
| 1 pc | 3-ph transformer |
| 1 pc | Main switch |
| 1 pc | kWh-meter |
| 1 pc | Plastic bin |
| 1 pc | Cutter |
| 1 pc | Stripper |
| 1 pc | Screwdriver 5/150 |
| 1 pc | Screwdriver Poz no 2 |
| 1 pc | Particle board with layout of a flat |

Tool Kits

MV1613 Electrical Student Tool Kit

Contents:

1 pc	Tool box
1 pc	Screwdriver set
1 pc	Flat nose pliers
1 pc	Diag. cutting nippers
1 pc	Wire stripper
1 pc	Hammer, cross pein
1 pc	Hacksaw frame
1 pc	Water pump pliers
1 pc	Woodworkers knife
1 pc	Measuring tape
1 pc	Adjustable wrench
1 pc	Voltage tester
1 pc	Brad awl
1 pc	Round-nose pliers

Test Instrument

Digital Multimeter
Clip-on ammeter

MV1614 Electrical Workshop Tools

1 pc	Storage cabinet
1 pc	Screwdriver set
2 pcs	Plumb-Bob
12 rolls	Plumb-Line
2 pcs	Level
2 pcs	Carpenters hammer
2 pcs	Drill brace
2 pcs	Center bit, 10 mm
2 pcs	Center bit, 16 mm
2 pcs	Center bit, 22 mm
2 pcs	Center bit, 25 mm
1 pc	Portable electric drill (Percussion)
2 sets	Masonry drills set 5-10 mm
2 sets	Drill set MAXI-Box
100 pcs	Hacksaw blade RS 1218
100 pcs	Hacksaw blade RS 1224
100 pcs	Hacksaw blade RS 1232
1 set	Set of ring spans 2-100 6-32 mm
1 set	Open ended spanner
2 pcs	Soldering pen, earthed
2 pcs	Soldering pen W61
2 pcs	Soldering pen W101
2 pcs	Hand file
2 pcs	Square file
2 pcs	Three sq. file
2 pcs	Half-round file
60 pcs	File handle
1 set	Tool kit 135 PC
3 pcs	Water pump pliers

ORDER INFORMATION ELECTRICAL INSTALLATION LABORATORY			
Product no	Description	Pc	Page
Low Voltage (LV)			
MV1600	Installation Kit, PVC Conduit	2	113
MV1601	Installation Kit Surface Wiring	2	114
MV1603	Installation Kit, 3-ph Motor	1	115
MV1604	Installation Kit, Light Control	2	116
MV1665	Residential Wiring Trainer (Kit)	2	117
MV1605	Assembly Frame	2	112
MV1606	Assembly Boards, Chipboard, set of three.	2	112
MV1608	Installation Training Equipment	1	108
MV1628	Induction Motor 3-ph Sq.Cage 50-60 Hz	3	108
MV1680	Assembly Kit for MV 1608	1	108
MV1610 -2	Distribution Protection Trainer	2	111
Tools			
MV1613	Tool Kit, Student, for electrician	8	118
MV1614	Tool Kit, Workshop	1	118
Measuring and Data Acquisition for PC			
MV1939	AC Power Energy Meter	1	187
MV1943	Measuring and Control Unit	1	185
MV2609	Control and Data Aquisition Software	1	186

Ref. 501

Section 8

Three Phase and Motor Control Systems

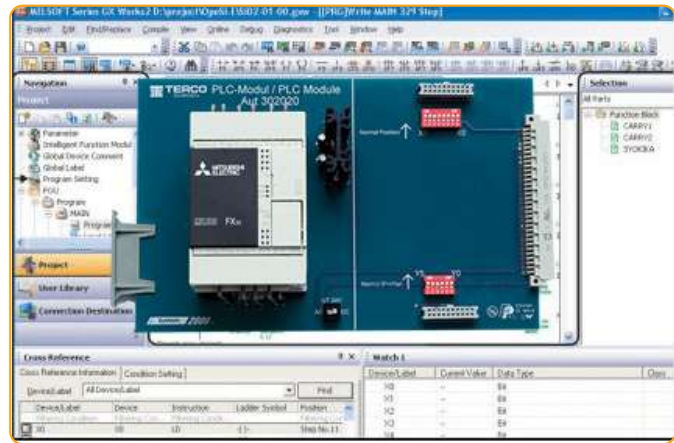

3-Phase AC

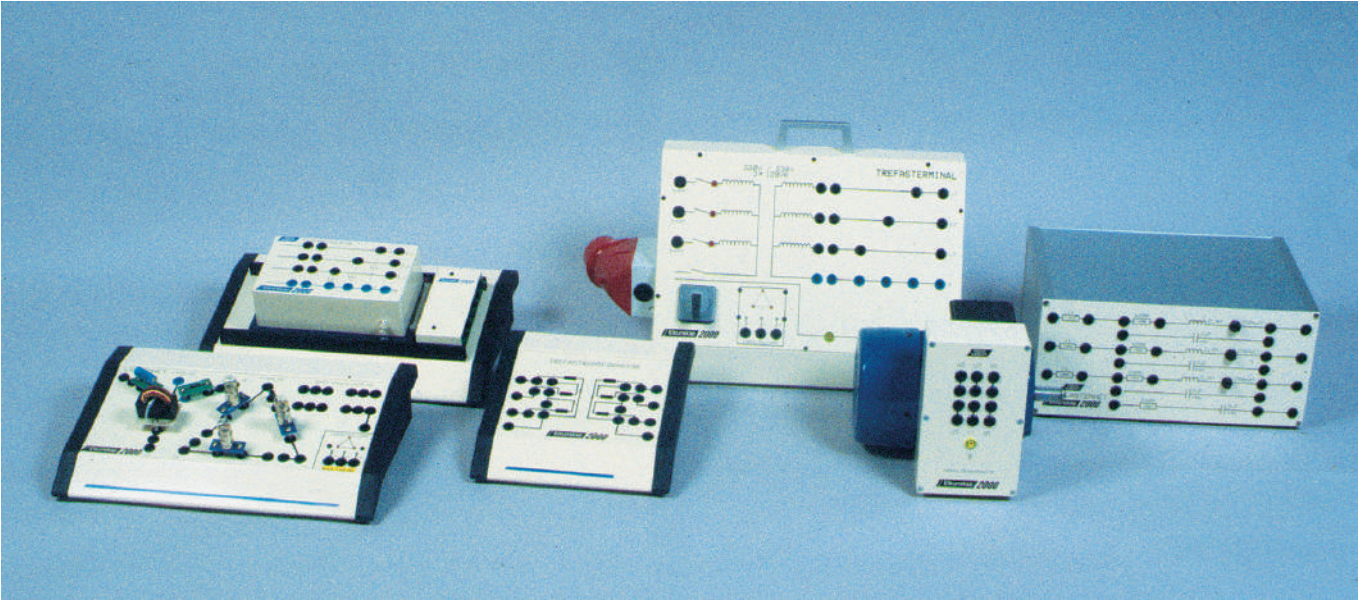

3-Phase AC

In this section, basic knowledge of 3-phase systems is studied. These include single phase and three phase systems, phase difference, motors, three phase transformers and control of motors. The practical exercises are completed in two stages, first using extra low voltage (14V) and finally with supply voltage 380-415V, 3-phase, 50-60Hz.

This laboratory package for 3-phase consists of a 3-phase simulator board which produces a 3-phase sine wave voltage of 14V. There is also a measuring point, power output (touch protected) and 4 fault finding switches. The board is used together with the Base Unit 2000.

The 3-phase simulator board has a multiplexer function which enables the student to study three different waveforms on one channel on the oscilloscope. To study the different types of load, a special load unit for the 3-phase simulator board is used. The student can connect in Y, D, series and parallel, with different loads. A phase sequence meter is also included.

Using the 3-phase terminal, 400V AC can be connected. Different loads can be applied from the load unit which has R, L and C loads.

7 multimeters are required, (preferably with both analogue and digital scales). 1 wattmeter and an oscilloscope with digital memory are also required in order to complete the course.

This course is a continuation from the course in DC and single phase AC circuits. It provides a sound base for the study of electrical engineering and basic knowledge of 3-phase AC. The ability to calculate and solve problems with different types of load with phase difference, is developed.

The knowledge and skill required to complete fault finding and the ability to correct faults in equipment used in a 3-phase system can also be achieved.

Extracts from the Laboratory Experiment Book

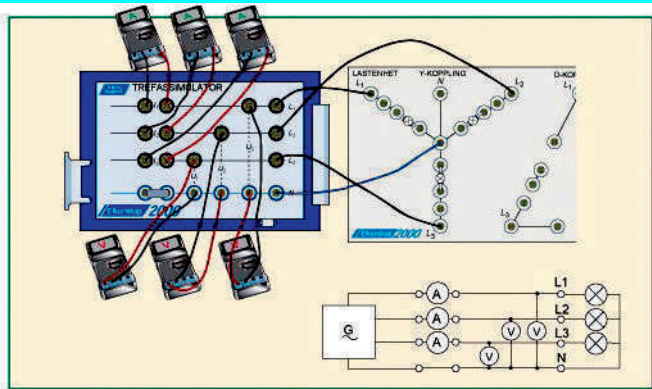

3.2 Measurement of a star (Y) connection.

Delta Connection

Do **not** switch on the Base Unit.

Connect the measuring instruments and the 3 resistors (33ohms) in delta formation as shown in 3.4.

Fill in the measured values in the table.

Calculate the power in each resistor and enter the values in the table.

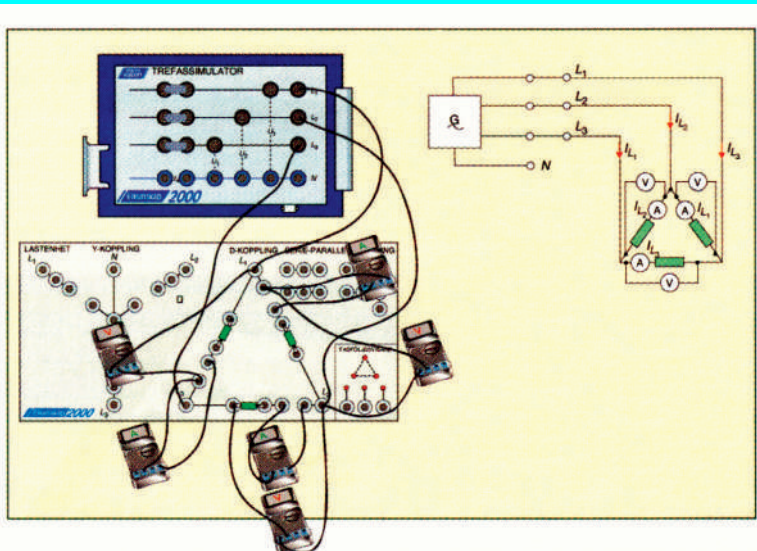

Calculate the total power.
Describe the relationship between the power developed in D resp.Y connections.

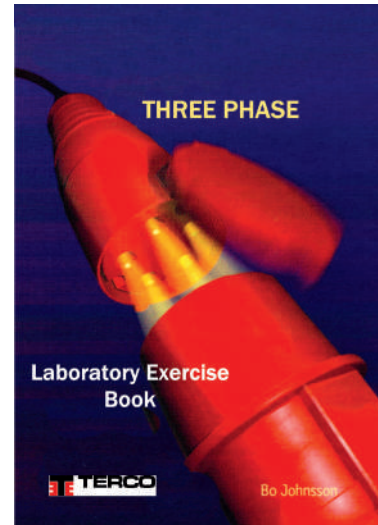

Technical Literature 3-phase

BOK102212 Laboratory Exercise Book
Contents:

- Measuring instruments
- Supply voltage and 3 Phase
- Balanced loads
- Unbalanced loads
- Phase shift
- Power measurement
- Phase compensation
- The transformer
- Motors
- Fault finding



ELE102000 Base Unit 2000

Base Unit 2000 is the base for the Lab System 2000. It is a Control Box comprising power supply, circuit box and PCB-holder.

Into the Base Unit laboratory cards can be fitted. The cards have been carefully designed to suit each particular area of study. The lab cards when fitted are automatically powered via D-sub connector.

Base Unit 2000 is a common unit to be connected to different equipment. The Base Unit is connected to 230 V AC and feeds voltage to the connected modules which are inserted between a pair of short guides and there connected to a 64-pole housing.

General data

Supply voltage 230 V , 50 - 60 Hz 1-phase

The unit has 6 outputs with following data:

Output 1 - 3: DC 12V / 3 A with LED indication and fuses

Output 4 - 6: AC 12V / 3 A with LED indication and fuses

Dimensions: 370 x 180 x 75 mm

Weight: 4 kg



ELE102230 3-Phase Simulator

The 3-phase simulator is used as a voltage source for most of the exercises using 3 phase.

Dimension: 100 x 140 x 40 mm

Weight: 1kg



ELE102231 3-Phase Load Unit Low Voltage

The 3-phase load unit is connected to the 3 phase simulator. From the load unit resistive, inductive and capacitive loads can be connected. These can be connected in star (Y) or delta (D). A phase rotation meter for voltages under 50V is built into the unit. The unit is delivered complete with the load components.

Dimension: 400 x 170 x 315 mm

Weight: 12 kg





ELE102234 3-Phase Transformer

The 3-phase transformer is designed to connect to the 3 phase simulator. Setting 1:2. The unit can be connected in different combinations of star(Y) and delta (D).

Dimension: 260 x 220 x 90 mm
Weight: 2.2 kg



ELE102236 Motor/Generator Model

This model consists of 3 coils which can be connected in Y or D. The coils have iron cores which are easily removed. The unit is complete with two rotors, one magnetic and one of metal plate. The 3 phase simulator is used to supply this model.

Dimension: 290 x 265 x 60 mm
Weight: 2.5 kg



ELE102232 Three Phase Terminal

The AC-motor can be connected to a 3-phase net by a 3-phase terminal with a 5-pole 16 A electrical output as to standard CEE17. Inside the terminal panel there is a control device for the 3-phases and the neutral line. The different phases are fused and in the terminal box is an insulation transformer (1:1) as well.

The terminal panel is equipped for current- and voltage measuring on all phases and includes a phase sequence display where LED indicate the phase sequence. The connection from the 3-phase terminal panel to the AC-motor is done with lab leads, directly or via the Contactor Unit. Only 4 mm safety lab sockets are used.

General data

Supply voltage: Prim. 5-pol. 400/230 V 3-ph, 50 - 60 Hz, 2,5A
Sec. 5-pol 400/230 V 3-ph, 50-60 Hz, 2,5 A
Dimensions: 510 x 190 x 320 mm
Weight: 8.3 kg



ELE102233 3-Phase Power Load Unit

The 3 phase power load unit contains load components R, L, and C for use on supply voltage of 230/240 V. Connection is made via touch protected sockets.

Dimension: 350 x 250 x 180 mm
Weight: 8.5 kg



ELE102237 Capacitor Box

Three motor capacitors are mounted on a podium box. Connection is via touch protected sockets. The capacitors can be connected in series or parallel.

General data

Capacitance: 3 x 15 μ F
Voltage: 450 V

Dimension: 240 x 220 x 150 mm
Weight: 2 kg



ELE102238 Current Transformer/ Earth Leakage Circuit Breaker

This unit consists of a current transformer and an automatic circuit breaker mounted on a pulpit box. Connection is via touch protected sockets.

General data

CT measuring range: 0.5 - 5A AC
Output Voltage: 0.1 - 4 V
ELCB: 4 pole

Dimension: 390 x 260 x 140 mm
Weight: 3 kg



ELE102239 Heating Centre

Two single phase outlets and a metal pipe are mounted on a pulpit box. The pipe is used to simulate a water pipe which can cause stray currents. Connection is via touch protected sockets.

Dimension: 260 x 220 x 90 mm
Weight: 1.5 kg



ELK102240 3-Phase Asynchronous Motor with Baseplate

A 3ph asynchronous motor having a suitable baseplate for connection to the brake unit. It can also be used in the course for motor control.

General data

Power: 250 VA
Voltage: 230/400 V

Dimension: 280 x 220 x 180 mm
Weight: 9 kg

ORDER DETAILS BASIC PRINCIPLES OF 3-PHASE AC			
Product no	Description	Pcs	Page
Simulated 3-Phase 14V			
ELE102000	Base Unit 2000	1	123
ELE102230	3-Phase Simulator	1	123
ELE102231	3-Phase Load Unit Low Voltage	1	123
ELE102234	3-Phase Transformer	1	124
ELE102236	3-Phase Motor/Generator Module	1	124
LEY500590	Safety Jumpers, black, Set of 10 pcs, 4mm	1	199
3-Phase Voltage 400 / 230V			
ELE102232	3-Phase Terminal	1	124
ELE102233	3-Phase Power Load Unit	1	124
ELE102237	3-Phase Box for Condensators	1	125
ELE102238	CurrentTransformer / Earth Leahage Circuit Breaker	1	125
ELE102239	Heating Centre	1	125
ELK102240	3-Phase Asynchronous motor with Base Plate	1	125
LEY500590	Security Jumper (black), Set of 10 pcs, 4 mm	1	199
Instruments & Accessories			
MAT220118	Digital Multimeter	6	191
MAT220350	Clamp-on Ammeter 0.5-240 A 2 V AC	1	188
MAT220020	Analogue Multimeter, moving coil	1	190
MV1939	Digital Wattmeter	1	187
MAT220730	GDS-1102A-U(CE) - Oscilloskop 2x70 MHz 25 GS/s	1	189
Books			
BOK102212	Three-Phase AC, Laboratory Exercises	1	122
Optional			
MV1830-HF	MV1830-HF 100 pcs Flex Set Area 1.5 mm ²	1	198

Ref.427

Terco reserves the right to make changes in the design and modifications or improvements of the products at any time without incurring any obligations

Motor Control System

A Motor Control package including the DC-motor and the AC-motor, controlled in different, modern ways. The AC- and the DC-drives are the main subjects to be studied in this package. Other types of drives can be studied in connection with motor control in industry.

The package also covers combinations with control techniques and electricity. The experiments are performed with AC- and DC-motors, which can easily be mechanically connected together. They can be loaded steplessly, with a magnetic powder brake. Experiments are made with different control equipment used to drive

and to control motors. Examples of control equipment are contactors, frequency converters, DC-drives and PLC. This equipment may be fixed in different units or on a module card to be connected to the Base Unit 2000.

Connection is done on terminals in an apparatus housing covering contactors, frequency converters, DC-drives, PLC and other applications. The experiment book is mainly built on connections with laboratory leads of safety design with 4 mm terminals.



The picture above shows the AC-Motor together with the Brake Unit and rpm-Meter.



ELK102240 Squirrel-cage 3-phase asynchronous motor

The motor is mounted on a steel base to be connected to a magnetic powder brake or to other electrical machines with a quick shaft coupling.

The AC-motor can be switched between Y and D. The supply to the main current circuit of the AC-motor leads through a 3-phase terminal connected to a 3-phase net.

The AC-motor can also be supplied via a frequency converter.

General data

Voltage:	230/400 V 3-ph, 50 - 60 Hz
Current:	1.55 / 0.9 A
Power:	0.25 kW, 1380 rpm, at 50 Hz
Power factor	0.68
Dimensions:	280 x 220 x 225 mm
Weight:	8 kg

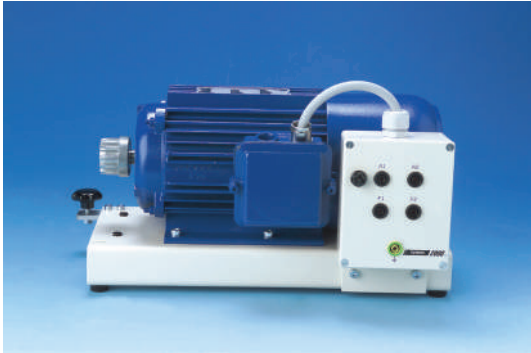

ELK102250 DC-Motor

The motor is mounted on a steel base to be connected to a magnetic powder brake or to other electrical machines with a quick shaft coupling. The DC-Motor has open shunt winding to make it possible to connect it as shunt or separate excited DC - Motor.

General data

Shunt wound	DC-motor.
Armature voltage:	160 V
Field voltage:	190 V
Armature current:	2.1 A
Power:	0.25 kW
Speed:	1500 rpm.
Dimensions:	380 x 220 x 250 mm
Weight:	13 kg



ELK102242 Magnetic Powder Brake

To be used together with the AC-motor ELK102240 and DC-motor ELK102250.

Brake 0-10 Nm adjustable with a 10-turn potentiometer.

General data

Power supply:	230 V, 50 - 60 Hz.
Effect consumption max:	25 W.
Dimensions:	300 x 160 x 200 mm
Weight:	7 kg



ELK102244 Tachometer

To measure the rpm of a motor, the tachometer is connected to the motor shaft. The tachometer shows an analogue signal output in form of voltage which is in proportion to the rpm of the rotating shaft. It works like a DC generator. The measuring instrument has a scale of 0-2500 rpm.

Voltage output DC 0-20 V, may be used for voltage feedback to the DC- or AC - Drive.

General data

Output:	20 V DC at 2500 rpm
Dimensions:	210 x 160 x 150 mm
Weight:	3 kg



ELK102246 AC - Drive

The AC-Drive is suitable to control the speed of an AC motor. It is perfect in many industrial applications e.g. pumps, fans, drilling machines etc. The AC - Drive can be set with 100 different parameters e.g. acceleration & retardation times, current limit, overload, alarm, speed ranges. It has also a built -in PID regulator. Here we focus the use of soft start and soft stop, rpm control and study the electronic overload protection.

General data

Max motor power:	0.4 kW
Input voltage:	230 V 1-ph, 50 - 60 Hz
Output voltage:	0-230 V 3-ph
Current:	2.5 A
Output frequency:	0.5-120 Hz

Dimensions:	230 x 250 x 245 mm
Weight:	2.6 kg



ELK102248 DC - Drive

The DC-Drive is used to run the DC motor. Here the parameters are set, as rpm, current limits, acceleration, ramps and others.

General data

Current max: 12 A
 Armature voltage: 0-180 V DC.
 Field voltage: 200 V DC.
 Field current max: 1 A
 Acceleration period: 0.2-5 s.
 Feedback with armature current or tacho.
 Supply voltage: 230 V 1-ph, 50 - 60 Hz.

Dimensions: 230 x 250 x 245 mm
 Weight: 2.6 kg

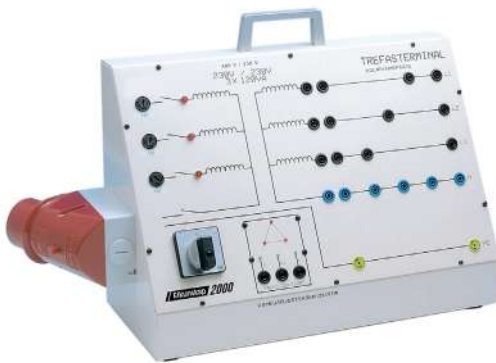

ELE102232 Three Phase Terminal

The AC-motor can be connected to a 3-phase net by a 3-phase terminal with a 5-pole 16 A electrical output as to standard CEE17. Inside the terminal panel there is a control device for the 3-phases and the neutral line. The different phases are fused and in the terminal box is an insulation transformer (1:1) as well.

The terminal panel is equipped for current- and voltage measuring on all phases and includes a phase sequence display where LED indicate the phase sequence. The connection from the 3-phase terminal panel to the AC-motor is done with lab leads, directly or via the Contactor Unit. Only 4 mm safety lab sockets are used.

General data

Supply voltage: Prim. 5-pol. 400/230 V 3-ph, 50 - 60 Hz, 2,5A
 Sec. 5-pol 400/230 V 3-ph, 50-60 Hz, 2,5 A

Dimensions: 510 x 190 x 320 mm
 Weight: 8.3 kg



ELE102000 Base Unit 2000

Base Unit 2000 is the base for the Lab System 2000. It is a Control Box comprising power supply, circuit box and PCB-holder. Into the Base Unit laboratory cards can be fitted. The cards have been carefully designed to suit each particular area of study. The lab cards when fitted are automatically powered via D-sub connector.

Base Unit 2000 is a common unit to be connected to different equipment. The Base Unit is connected to 230 V AC and feeds voltage to the connected modules which are inserted between a pair of short guides and there connected to a 64-pole housing.

General data

Supply voltage 230 V , 50 - 60 Hz 1-phase

The unit has 6 outputs with following data:

Output 1 - 3: DC 12V / 3 A with LED indication and fuses
 Output 4 - 6: AC 12V / 3 A with LED indication and fuses

Dimensions: 370 x 180 x 75 mm
 Weight: 4 kg



AUT302011 Control Module

The AC-motor is started and stopped by push button controlled electrical switches, located in the Control Module. They are specified with indication as normally closed (NC) or normally open (NO) contacts and there are two of each. In the Control Module you also find a number of indicating lamps. Two of them are red and two of them are green. To control the motor 24 V AC is used which is supplied from the Base Unit 2000, where the Control Module is to be connected. The Base Unit may be loaded up to 50 VA. The Control Module holds also 24 V DC for other experiments.

General data

The Control Module consists of:

- 2 push buttons, NC
- 2 lamps
- 2 push buttons, NO
- Output 24 V DC and 24 V AC

The Control Module has to be connected to the Base Unit 2000.

Dimensions: 240 x 140 x 55 mm

Weight: 0.7 kg



AUT302012 Contactor Unit

The Contactor Unit is used to control the motor. It connects the 3-phases from the 3-phase terminal to the AC-motor.

3 mini-contactors are placed in the Contactor Unit. If any of the contactors is in use, this is indicated by a LED. Two of the contactors have an auxiliary contact block and the third one has both, an auxiliary contact block and a thermal overload protection which is released at too high current output at any of the three phases meant for the motor drive. The time relay can be connected to one of the contactors. The auxiliary contact blocks are used together with the contacts in the Control Module when controlling the AC-motor. Mains supply terminals of safety design.

General data

Operating voltage: 24 V AC

Main voltage: 400 V 3-ph, 50 - 60 Hz

Max current: 10 A

Dimensions: 390 x 260 x 130 mm

Weight: 3.3 kg

PLC - System

A PLC is a small Mini -Computer for industrial use comprising all necessary logic functions gathered in one housing. The input to our PLC is done from, for example, different sensors or electrical contacts. The output of the signals is done via contactors, pneumatic valves etc.

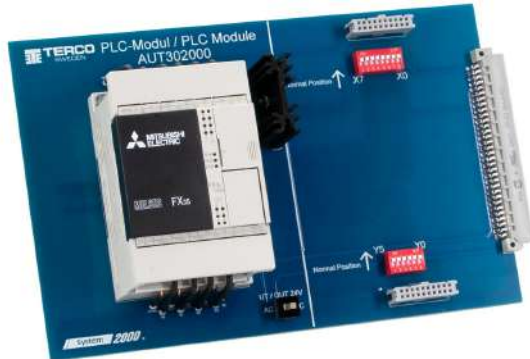

USB Programming Cable for Mitsubishi Melsec FX Series PLCs,



AUT302000 PLC Module

The PLC - Module has to be connected to the Base Unit 2000. To program a PLC a PC is connected to a programming port via a cable alternatively a PC software may be used for programming.

The PLC-module contains a PLC-system with sockets to connect any chosen module card. For the sockets there are several switches to simulate faults at the different in- and outputs.

General data

Mitsubishi Melsec FX0-14 MR PLC (24 V)

8 inputs and 6 outputs

Input and output of the PLC is connected to a 20 pin socket

Dimensions: 240 x 140 x 55 mm

Weight: 0.5 kg

AUT302001 Simulation Module

The signal levels on the inputs can be altered through a simulation module, plugged into the sockets of the PLC module.

General data

Shows input status with 6 LED and has out-going signals simulated by 8 on/off switches.

Dimensions: 100 x 140 x 40 mm

Weight: 0.1 kg



AUT302008 Socket Adapter

To connect the PLC module to an control object, a 4 mm socket adapter is used. It is plugged onto the sockets of the PLC module and thus all in- and outputs of the PLC-system are connected to the 4 mm socket adapter. Thereupon it is easy to connect the PLC system to another control object with 4 mm lab leads.

The socket adapter has also four electrical switches to be able to give in-signals to the PLC-system. The electrical switches can be turned to NC or NO.

General data

Dimensions: 100 x 140 x 40 mm

Weight: 0.1 kg



AUT310712 Programming Software for PC

Programming software GX Works2 for programming of PLC from PC including USB cable.

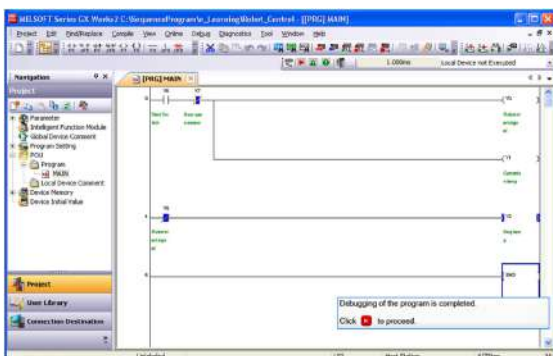

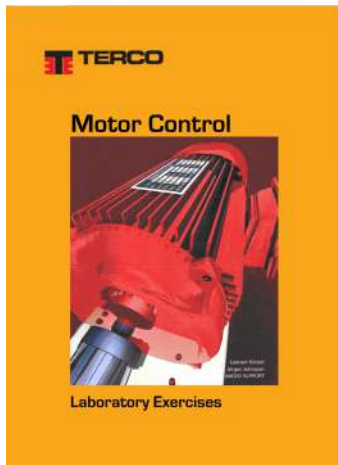

BOK103615 Experiments Book & Motor Control

Contents

- Ratings of a Motor
- Clockwise and Counter Clockwise Rotation of a Motor
- Overload Protection
- Control of a Motor
- Y / D Connection
- Faultfinding Control Circuit
- Motor Control of AC Drives
- Motor Control of DC Drives
- Motor Control with PLC Connected to Drives
- Faultfinding on PLC
- Sensors
- Control of a Rotary Index Table

ORDER DETAILS MOTOR CONTROL SYSTEM INCL. PLC			
Product no	Description	Pcs	Page
Motor Control System			
ELK102240	Squirrel-Cage 3-Phase Asynchronous Motor	1	127
ELK102250	DC-Motor	1	128
ELK102242	Magnetic Powder Brake	1	128
ELK102244	Tachometer - RPM-Meter	1	128
ELK102246	Frequency Converter AC-Drive Module	1	128
ELK102248	DC-Drive Module	1	129
ELE102232	Three-Phase Terminal	1	129
ELE102000	Base Unit 2000	2	129
AUT302011	Control Module	1	130
AUT302012	Contactormodule	1	130
LEY500590	Safety Jumpers, black, Set of 10 pcs, 4mm	1	198
PLC			
AUT302000	PLC Module for Base Unit 2000	1	146
AUT302001	Simulation Module	1	146
AUT302008	Socket Adapter	1	146
AUT310712	Programming Software GX Works2 Class-Set	1	146
Optional			
ELE102002	Storage Rack 1 row	1	196
MV1830-H	Flex Set 100 Safety Leads 5 colours, Retractable shroud	1	198
MAT220118	Digital Multimeter	2	191
Books			
BOK103615	Experiments Book Motor Control	1	137

Ref.419

Terco reserves the right to make changes in the design and modifications or improvements of the products at any time without incurring any obligations

MV4207-1 DC-Motor Drive

Single-phase 4-Quadrant Rectifier, Three-Phase supply
Covers the latest development in DC-motor operation with analogue control. The equipment is designed to work according to different industrial environments. The drive has signal in- and outputs for connections to slave and/or master drives.

To cover a wider range of machines regarding voltage and speed the primary supply is taken from a standard 3-phase outlet which will supply the inverter bridges by 2-phase 400 V.

The design will enhance the possibilities of learning the theory and practice of understanding the operation of 4Q-drives for both single drives and the basic understanding of three bridges and their commutation.

The 4-Q-DC-Drive can be used in the conception of speed/torque control versus electro-machine theory. When braking, the energy is transferred directly to the supplying network by operating in all four quadrants.

Technical Specification

Input voltage:	3-phase 3 x 400 V + N + PE, 50-60 Hz
Input max current:	16 A, rotor inductance is included
Output voltage:	0-250 V DC
Output current:	0 - 12 A (max 16 A)
Nom. output power:	2 kW
Design:	Tutorial where the 4Q industrial/professional aspects are enhanced
Control:	Manually operated Digital / Analogue
Front control parameters:	12
Feedback:	DC-tacho or armature voltage
Built-in unit for immediate:	U+I+P signals, isolated, including MUX for oscilloscope.
Built-in protections and contactor relays	
Dimensions	520 x 450 x 280 mm
Weight	23 kg

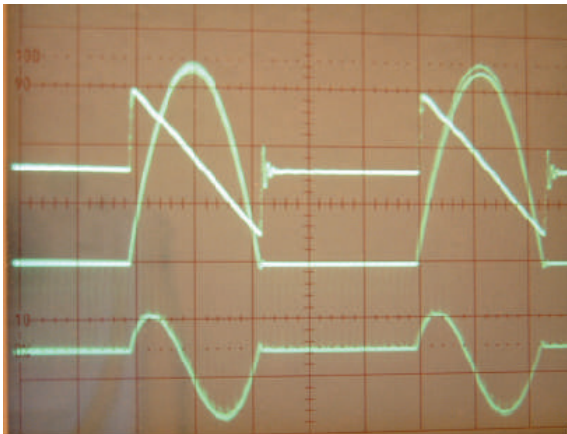

Manuals

Consist of a theory section and an exercise section. The theory part explains for example general theory of the conditions for torque developed in an arbitrary machine, while the exercise section contains theory sections that are directly connected to the different experiments. The Manual consists of a complete binder together with an additional section, which will explain the UIP-unit (Voltage/Current/Power – unit) together with oscilloscope snap-shots showing different operation modes of the rectifier.

Standard Settings

12 Parameters are set manually:

Typically: Speed, Max Speed, Acc ram, Flux, Ret ramp, Ilim, Current/Speed proportional, Current demand in/out, etc.

Floating switches and potentiometers are used to study step response and stability. The results of the dynamic response regarding voltage, current and immediate power can be studied fully isolated on a standard oscilloscope via the built in isolation amplifier and multiplexer.



MV4207-3 DC-Motor Drive

Three-phase 4-Quadrant Rectifier, Three-Phase supply covers the latest development in DC-motor PC-controlled operation with 6 pulse 4Q rectifiers. The equipment is designed to work according to different function principles and it is possible to explain several different types of DC-drives depending on the purpose and industrial environment from traction to paper- and steel mills.

Output current/voltage can be chosen to optimize torque/angular speed or to optimize other parameters by using a PC and the enclosed software. When braking, the energy is transferred directly to the supplying network by operating in all four quadrants. The field rectifier can be programmed manually or from a PC for optimized field control.

The 4Q DC Drive can be used in the conception of speed/torque control versus electro-machine theory. The equipment is also suitable for experiments and tests in industrial applications.

Technical Specification

Input voltage: 3-phase 3 x 400 V + N + PE, 50-60 Hz

Input max current: 16 A

Output voltage: 0 - 400 V DC

Output current: 0 - 12 A (max 16 A)

Nominal output power:

2 kW (max 3 kW)

Design: Tutorial but with the PC-controller industrial / professional aspects enhanced.

Control modes: Manually by front components, Manually by Operator Station, PC by RS 232 + "DELite" + software

Front controls: Manually Digital > 20, Analogue > 4

Configuration: by PC or Operator Station

Self-tuning: by PC or Operator Station

Built-in protections and contactor relays

Dimensions 520 x 450 x 280 mm

Weight: 25 kg

Built-in Instruments and Oscilloscope Functions

The enclosed software will make it possible to configure the internal connections and operating principles by using a standard PC. On the screen it is possible to monitor 3 analogue instruments and edit a number of signals/parameters in parallel, which can be saved and printed. The number of parameters/tags possible to study exceeds 200.

Standard Settings and Advanced Settings

Most parameters are set by default but settings can also be done manually from the front controls.

Typically:

Speed, Max Speed, Acc ram, Flux, Ret ramp, Ilim etc.

Advanced settings, >200 parameters/tags, are performed by Operator Station on the unit, PC nearby the unit, connected to COM1 (COM2).

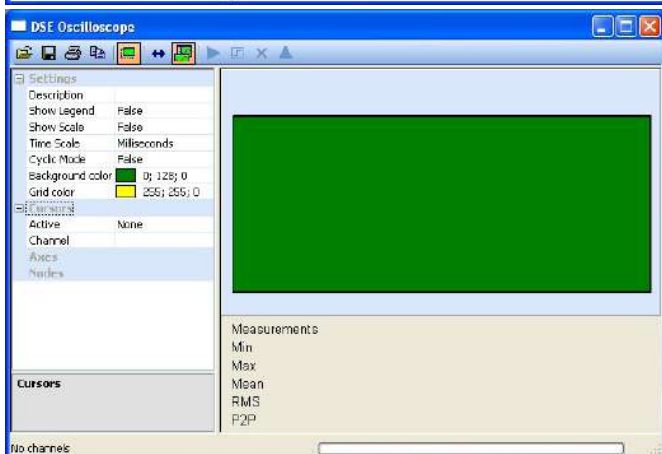
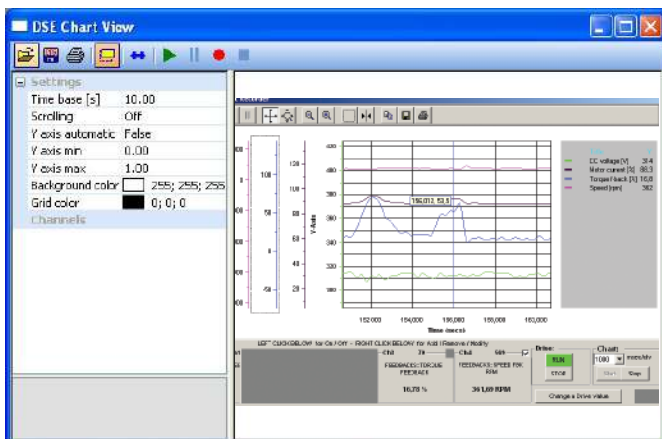

Manuals

Consists of a large quantity of experiments where related theoretical analyzes and explanations are performed in each experiment. Experiments furtheron covers basic operation and autotuning as well as more advanced operation directly from the drive keypad (operator station) or from PC where signal analysis also are possible by means of the chart recorder and the oscilloscope function.

MV2658 PWM DC Control Module

MV2658 is an indispensable equipment in the electrical machines laboratory as it can be used in several different types of applications.

It can be used as a DC-Machine Drive in the range up to 1.2kW, a Generator Field Controller (VAr controller), or a Machine Brake Controller suitable with Terco equipment in the range up to 3.3kW

Technical Specifications

- PWM (16kHz) Based Excitation Voltage 0-260VDC.
- Selectable Current Limit Levels (front panel switch): 1.7ADC, 2.5ADC, 3.5ADC, 5.0ADC, 7.5ADC.
- Fixed Excitation Output 200VDC (for DC Drive application).

- PWM Controlled Excitation on the front panel control (0-100% Duty Cycle) or from the control input (fully isolated, 0-10VDC = 0-100% Duty Cycle).

The control input can be used for instance in PC based control together with Terco DAQ software. (Optional analog output interface unit necessary).

- Control Methods selectable between PWM Controlled Excitation Voltage Feedback and External Analog Voltage Feedback.
- Power Supply 220-240VAC, 50/60Hz
- Dimensions: 255 x 195 x 330mm
- Weight: 8kg



MV1024 Tachogenerator

The generator is mounted inside a protective guard. The cover is hinged and can be fixed by a locking screw.

General Data

DC Generator 14 V at 1000 rpm
(with trim potentiometer)

Dimensions 300 x 260 x 130 mm

Weight 2 kg

Please note : The protective guard can be fitted between the machines to cover the rotating couplings, thus minimising the risk of accidents from rotating machinery.



MV1055 Spacer Shaft

To be used as an shaft extension between MV1054 torque/speed meter and either the test machine or the braking/driving machine to give space for the MV1024 tachometer generator when doing closed-loop experiments with DC-drives.

MV1055 is also suitable between the MV1010 flywheel and the MV1054 torque/speed meter.



MV4206-1 AC-Motor Drive

Semi 4Q frequency converter with MOS FET technique and a fixed intermediate DC-link. It covers the latest development in AC-motor operation with frequency converters. The equipment is designed to work according to different function principles and it is possible to explain several different types of frequency converters existing today.

4-Q-Drive: The Frequency Converter can be used in the conception of speed/torque control and electro-machine theory. The equipment is also suitable for experiments and tests in industries i.e. far beyond the area that the experiments show.

When braking, the energy is transferred by the DC-link and a brake chopper to a built-in load resistor.

There is also an additional adjustable DC-injection brake.

Technical Specification

Input voltage:	3-phase	3 x 400 V + N + PE, 50-60 Hz
Input current:		16 A max
Output Power:		1.5 kW
Output voltage:		3 x 230 V
Max output current:		7 A
Max output frequency:		100 Hz
Choice of polygon:		automatic
Breaking points:		automatic
Internal switch frequency:		3 kHz max
Type of modulation:		PWM sensorless vector
Intermediate DC-voltage:		average value 300 V DC
Inverter bridge:		MOSFET
Control voltage:		+/- 10V DC analog, 0-24V DC Digital

Dimensions	520 x 450 x 280 mm
Weight	16 kg

Built-in Instruments Functions

The enclosed software will make it possible to configure the internal connections and operating principles by using a standard PC. On the screen it is possible to monitor 3 analogue instruments and scroll a number of signals/parameters in parallel, which can be saved and printed. The number of parameters/tags possible to study exceeds 200.

Standard Settings and Advanced Settings

Most parameters are set by default but settings can also be done manually from the front controls.

Typically:	Speed, Max Speed,
Acc ram,	Flux, Ret ramp, I-lim etc.
Advanced settings:	>200 parameters/tags, are performed by Operator Station on the unit, PC nearby the unit, connected via the comport.



Semi 4-quadrant Drive

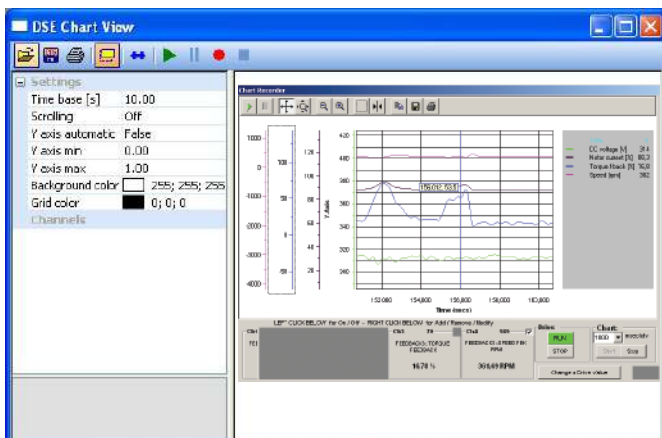

Manuals

consist of a theory section and exercise section together with a software description. The theory part explains for example general theory of the conditions for torque developed in an arbitrary machine, while the exercise section contains theory that are directly connected to the different experiments.

The instruction manual is enclosed as a complete binder together with a corresponding CD.



MV2661 AC-Control

The MV2661 is an AC drive primarily designed for speed control of a 3-phase squirrel cage induction motor. Its purpose is to create a sinusoidal (or close to) 3-phase voltage that is connected to the stator of an AC-motor.

The AC-drive controls the pulse width and the frequency of the supplied voltage and can therefore keep the motor running at constant speed although the mechanical load applied at the rotor shaft varies. The AC drive includes an autotune-function which automatically identifies the electrical and mechanical parameters of the connected induction motor.

General data

Max. Applicable Motor Output	1.5kW
Max. Applicable Motor Output	2.0hp
Rated Output Capacity	2.9kVA
Rated Output Current	7.5A
Maximum Output Voltage	3-ph prop. to input V.
Supply Input Current	15.7A (Fused 15A)
Supply Voltage/Frequency	1-phase 200-240VAC, 50/60Hz
Voltage Tolerance	+/-10% (180-264V)
Frequency Tolerance	+/-5% (46-63Hz)

Dimension	340x250x150mm
Weight	6.2kg

The drive is capable of operating machines up to 1.5kW. It controls the output voltage 3x(0-240)V and frequency 0.1-600Hz. The maximum output current is 7.5A and the input current 15.7A (fuse size 15A). It is mainly designed to operate together with TERCO MV-machines, which are sized 1.1 – 1.5kW.

The AC CONTROL MV2661 is furtheron equipped with an internal brake chopper and an internal brake resistor which makes it possible to study short ramp time braking coarses.

All essential signals are connected to the front to make it possible not only to run typical experiments verifying the theory but also to make it possible to run the drive out of more advanced industrial aspects.

ORDER DETAILS FOR AC- AND DC-DRIVES			
Product no	Description	Pcs	Page
DC-Drives			
MV4207-1	DC-Drive	1	133
MV4207-3	DC-Drive, Three-Phase supply	1	134
MV1024	DC-Tachogenerator incl. Cover, trim potentiometer incl.	1	178
MV2658	MOSFET - PWM Module	1	135
MV1055	Spacer Shaft	1	135
MV1974	Voltmeter, moving coil 0 - +/- 300 V	1	188
AC-Drives			
MV4206-1	AC Motor Drive	1	136
MV2661	AC-Control	1	137

Ref.201

Section 9

Process-, Energy, Control- and Servo- Systems

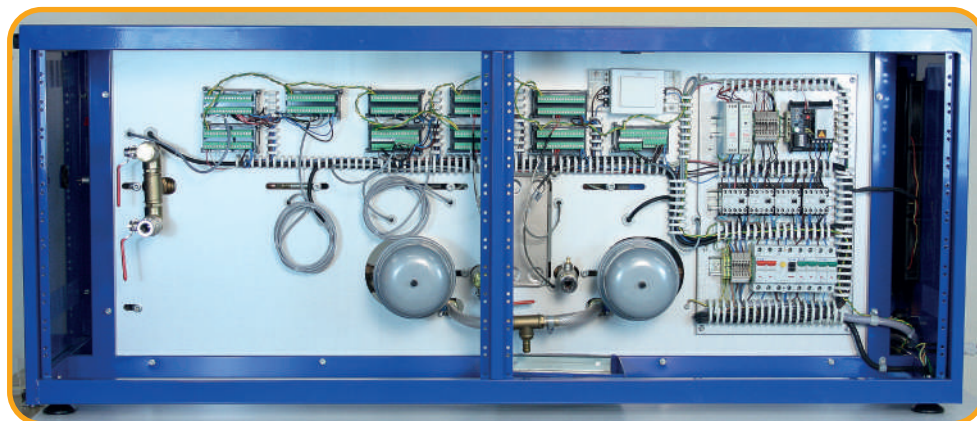

Process Control Technology and Measuring Technique PID



Process control and measuring techniques is a modern educational package containing technical literature and hardware. The system is developed and tested in a working environment in line with the demands of modern education. The program product PID-Future together with the interface (PF-1) and many different control components combine to give a package that can handle the most common control processes, together with the help of a computer.

The program package consists of a PID regulator with which it is easy to adjust the different regulation parameters P, I and D and at the same time supervise the results. All of the Lab-Cards can be assembled on the Base Unit 2000. The equipment used in the experiments can also be used for Control Techniques (basic) and Control Techniques (advanced). The experiment book has clear instructions with 4-colour illustrations.

The educational package includes technical information, exercises and experiments

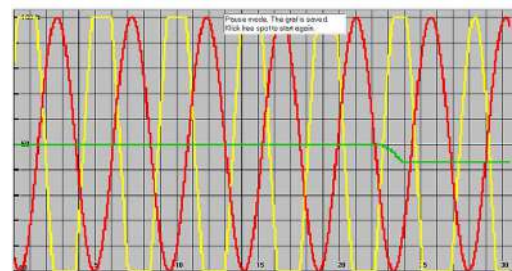
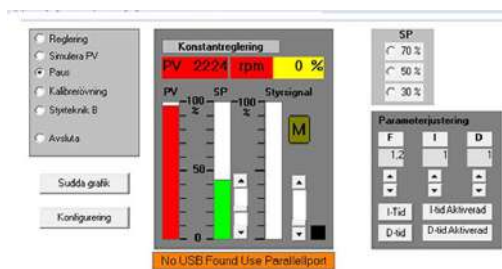

Pause mode. The Graph is saved.

PRG302200 PID-Future Software

Windows based Programme Software for measurement, control and regulation. Setting of the set points, P, I and D. Simulation of a sine wave formed process value. Parameters are shown in number form and graphical. The programme material is bought under licence for 8 users. The program is based on Windows.



ELE102000 Base Unit 2000

The starting point of this laboratory system is Base Unit 2000, a control panel and PCB-holder.

The Base Unit can be loaded with laboratory cards which have been carefully designed to suit each particular area of study.

The Lab Cards are placed in slots and are automatically powered via a D-sub connector.

General Data:

Supply voltage: 220 - 240 V 50-60Hz 1-phase.

The unit has 6 outputs with following data:

Outputs 1-3: DC 12V / 3A with LED indication and fuse.

Outputs 4-6: AC 24V / 3A with LED indication and fuse.

Dimension: 370 x 180 x 75 mm.

Weight: 4 kg



AUT302201 PID Interface PF1

PF1 is to be mounted on the Base Unit 2000 and connected to a PC using the software PRG 302200 (See page 5). The PF1 has one analogue input, one analogue output, current or voltage loop, one PWM output, one output for control of the fan and two inputs for temperature sensors.

General data:

Input Signal: 0-20 mA
 4-20 mA
 0-1 V (diff.input)

Output Signal: 0-20 mA
 4-20 mA
 20-0 mA

Smart Temperature Transmitter
 20-4 mA -30°C - +130°C

PWM output: 1Hz

Dimension: 135 x 140 x 36 mm
 Weight: 0.5 kg

AUT302202 Temperature Module PF2

PF2 is a Temperature Regulation system including a heating chamber (oven) of approx. 50W, a temperature sensor and a fan for cooling. It is connected to and regulated by the PID Interface PF1.

General Data:

Heating Chamber: 50 W
 Dimension: 145 x 140 x 105 mm
 Weight: 0.5 kg



AUT302203 Speed Regulation Module PF3

PF3 consists of a 12V DC motor, which has a 12V DC generator as a load. The purpose is to regulate the speed of the motor. It is connected to the PID interface PF1.

Dimension: 150 x 140 x 60 mm
 Weight: 1 kg





AUT302204 Signal Converter PF4 Including Band Cable

PF4 is an interface for adapting signals from the PC based PID- Future to the Tank Model. It is connected to PF1.

The Signal Converter is required to communicate between the PID Interface PF1 and the Car and Tank Models.

Dimension: 140 x 58 x 24 mm
Weight: 0.2 kg



AUT302103 Regulator module

The analogue controller, complete with contact module and band cable, is connected to base unit 2000.

Setting of P, I and D is completed by trimming the potentiometer and setting of relays, rather than input data via a computer.

Dimensions: 240 x 140 x 30 mm
Weight: 0.3 kg



AUT302102 Tank Model

The Tank Model can be used to regulate level and flow. It is connected via a band cable to the signal converter PF4 which is connected to the regulator interface PF1. The model consists of a container (tank) having a capacity of 1 liter, where the level is measured at 2 places by means of a pressure gauge. The level tank can be divided into max three volumes to create different flow levels in the process. There are four taps for draining off the water to create different loads. The flow to the tank is measured by a sensor on a turbine wheel. The pump motor is driven via a rectifier which regulates the speed of the pump.

General data:

Supply Voltage: 24V DC
Current: 5A

Dimension: 550 x 350 x 510 mm
Weight: 11.7 kg

EB3000 Energy- and Process Control Trainer

EB3000 Energy and Process Trainer will be used for studies in:

- Transformation of energy. For example, from electrical Power to warm water.
- Storage of energy.
- Distribution of energy.

"Exercises on the most common application that occurs in energy transport systems"



The equipment consists of a primary circuit which transports energy to a secondary circuit by a heat exchanger. Boiler and pumps are controlled individually via potentiometers on the front (or an operator's panel or a PC). Values for temperature, pressure and flow may be read out directly with separate instruments, or via the HMI (Human Machine Interface) operator's panel. All values shown on the operator's panel may also be transferred to a PC and used in an Excel-sheet.

Control of the EB3000 can also be done via PC and VNC viewer.

Technical Specification

The Energy Process Trainer is built up with industrial components on a varnished steel construction. All signals are to be found on the internal mode bus.

As option it can be delivered with external connections. All signals can be obtained as analogue industrial standard 4–20 mA or 0–10 V.

Boiler power:	1000 W
Pumps:	2 x 25 W
Working temperature:	Nominal up to 65°C
Flow:	Primary 2-7 l/min; secondary 1-6 l/m

Dimension:	
Length x depth x height:	1540 x 510 x 620 mm
Total weight: approx.:	125 kg

Terco reserves the right to make changes in the design and modifications or improvements of the products at any time without incurring any obligations

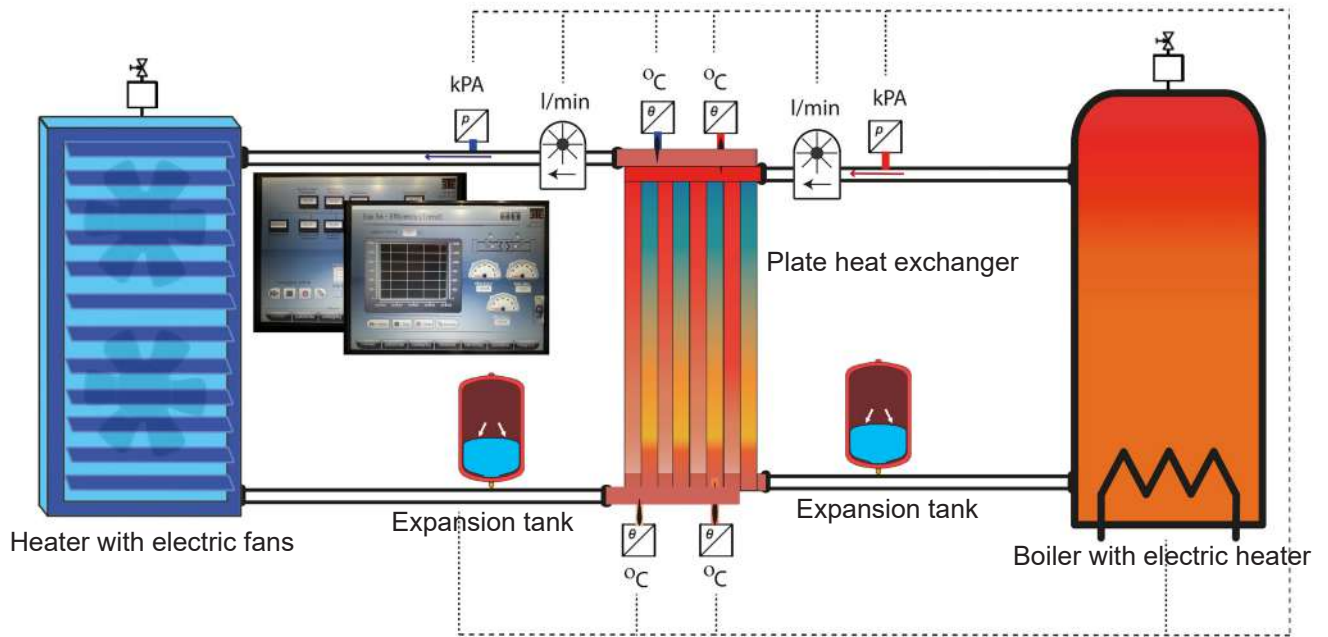

Principle Diagram

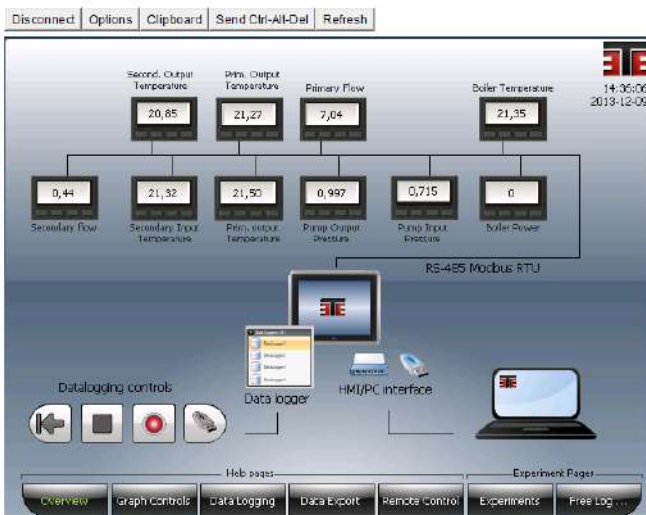

Overview

The overview page shows how EB3000 is constructed. On this page you can see the instruments via Modbus and how they are connected to the operator's panel. EB3000 can be connected to internet and be remote controlled from any computer. Moreover, you can log, and store data in the memory of the operator's panel for later export of the data to a USB memory. All exercises are prepared in the programme. Facts, instructions and questions are included in the Manual. Teachers Manual is included.

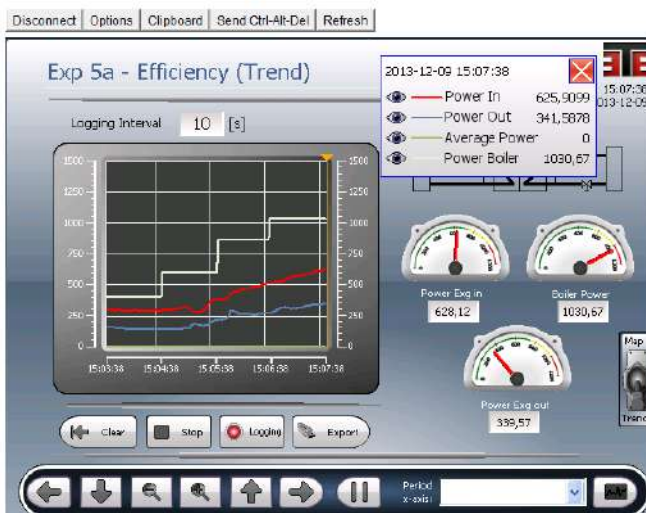

Graph Controls

The graph control panel is accessed by pressing anywhere in the diagram. The active trend display can be paused whilst data continues to be logged allowing instant analysis of live data. Pan and zoom functions enable close up investigation of data trend curves.

Energy and Process Control Trainer Laboratory Exercises



- Chapter 1 – Introduction to the Energy Process Trainer EB 3000
- Chapter 2 – The Energy Process Trainer corresponding to reality
- Chapter 3 – Function of the components
- Chapter 4 – Fundamental concepts within energy
- Chapter 5 – Experiment; Heat and temperature
- Chapter 6 – Experiment; Flow control
- Chapter 6 – Experiment; System pressure
- Chapter 7 – Experiment; Measurement of effect
- Chapter 8 – Experiment; Efficiency
- Chapter 10 – Free log
- Chapter 11 – Specifications

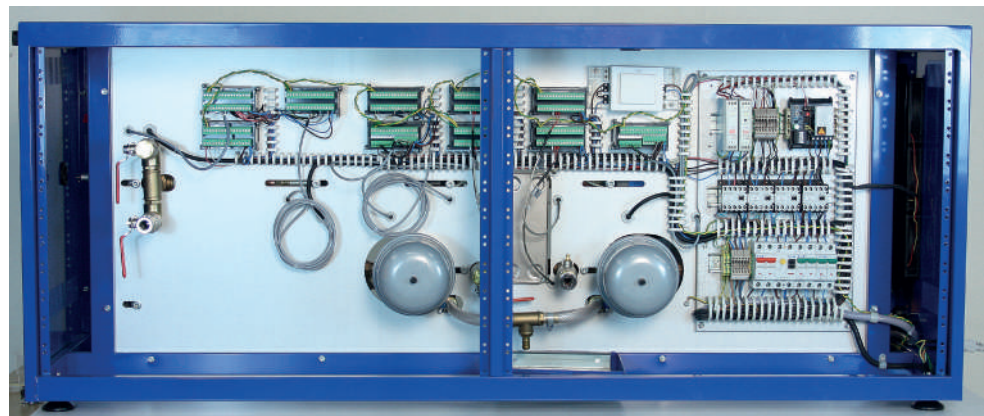

Rear side of EB3000

ORDER INFORMATION ENERGY AND PROCESS CONTROL TRAINER

Product no	Description	Pcs	Page
EB3000	Energy and Process Control Trainer including: Ind Pressure vessel for filling water	1	165
ELE309902	Table with wheel for Energy Bench	1	165
	Laboratory Exercises and Teachers Manual included	1	

Control Techniques - PLC



The Basic Control Technology course offers a good ground training before more advanced courses in control technology and automation. The courses in this concept make use of a Laboratory Exercise Book.

The logic module for the Base Unit 2000 contains a logic block with switch and light diodes and various other relays.

The IDEC PLC board has 12 inputs and 8 outputs. Inputs and outputs of the PLC are connected to a 20 pin socket. The PLC is to be programmed by using the software Automatic Organizer.

The simplest PLC practices can be performed using a simulator board which shows the input status in the form of 6 LED's and has output signals simulated by 8 on/off switches.

With the traffic lights module, pedestrian and vehicle control can be programmed. The cylinder module introduces pneumatics and sensors.

The ball selection module gives more training with pneumatics. Balls of metal and non-metal are taken from a storage area and sent to a selection station where the balls are detected by an optical sensor.

The laboratory package includes:

- Base Unit 2000
- Logic Module
- Software Automation Organizer
- PLC-Module
- Ball Selection Module
- Simulation Module
- Cylinder Module
- Terminal Block Module
- Traffic Lights Module

Technical Literature:

BOK312002 Basic PLC, Laboratory Exercises

ELE102000 Base Unit 2000

The starting point of this laboratory system is Base Unit 2000, a control panel and PCB-holder.

The Base Unit can be loaded with laboratory cards which have been carefully designed to suit each particular area of study.

The Lab Cards are placed in slots and are automatically powered via a D-sub connector.

General Data:

Supply voltage 220-240V 50-60Hz 1-phase.

The unit has 6 outputs with following data:

Outputs 1-3: DC 12V / 3A with LED indication and fuse.
Outputs 4-6: AC 24V / 3A with LED indication and fuse.

Dimension: 370 x 180 x 75 mm.

Weight: 4 kg



Other supply voltages available on request.

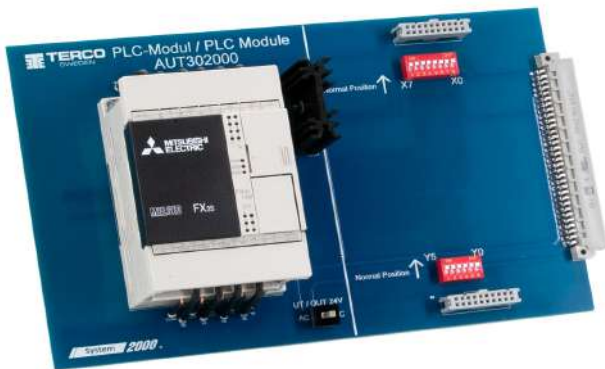

USB Programming Cable
for Mitsubishi Melsec FX
Series PLCs,



AUT302000 PLC Module

The PLC - Module has to be connected to the Base Unit 2000. To program a PLC a PC is connected to a programming port via a cable. Alternatively a PC software may be used for programming.

The PLC-module contains a PLC-system with sockets to connect any chosen module card. For the sockets there are several switches to simulate faults at the different in- and outputs.

General data

Mitsubishi Melsec FX3s DS PLC (24 V)

8 inputs and 6 outputs

Input and output of the PLC is connected to a 20 pin socket

Dimensions: 240 x 140 x 55 mm

Weight: 0.5 kg



AUT302001 Simulation Module

The signal levels on the inputs can be altered through a simulation module, plugged into the sockets of the PLC module.

General data

Shows input status with 6 LED and has out-going signals simulated by 8 on/off switches.

Dimensions: 100 x 140 x 40 mm

Weight: 0.1 kg



AUT302002 Traffic Lights Module

The Traffic Lights Module is to be connected to the PLC Module. The Module simulates a traffic crossing for cars and pedestrians at a pedestrian crossing.

When experimenting with the Traffic Module, the student has the task of creating a PLC program to control the traffic lights.

There are red and green lights for the pedestrian crossing, and red, yellow and green for the vehicle traffic.

Dimension: 100 x 140 x 40 mm

Weight: 0.1 kg

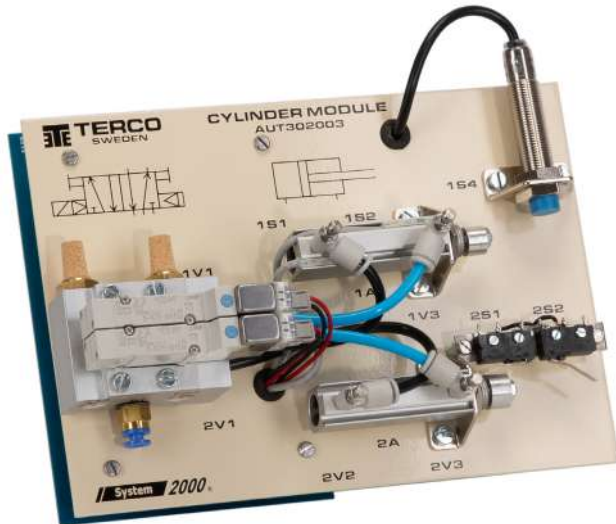

AUT302003 Cylinder Module

This module is used to study the actions and uses of electrically controlled valves.

General Data:

The module consists of two pneumatic cylinders, two electrically controlled valves and four sensors. The components are mounted on a metal panel. Compressed air (3-8bar) is required.

Dimension: 200 x 140 x 90 mm
Weight: 1 kg

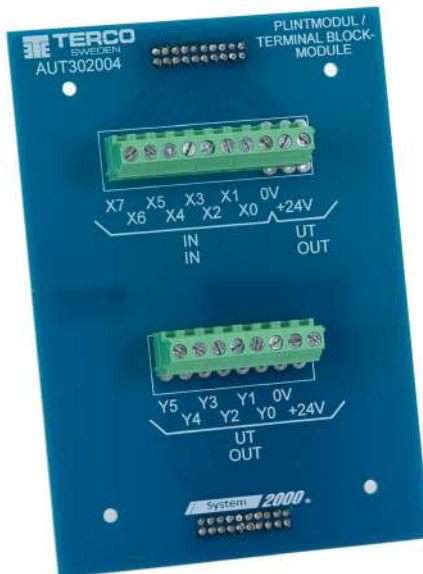

AUT302004 Terminal Block Module

The Terminal Block Module is to be connected to the PLC-Module. The PLC-Module together with the the Terminal Block Module will be used for connections to the Ball Selection Module.

The connections will be made with one wire to each output and input.

In this case there will be 8 inputs and 6 outputs for control of the valves (for the cylinders), and sensors on the Ball Selection Module.

Connection between PLC and Lab Equipment
Dimension: 100 x 140 x 40 mm
Weight: 0.1 kg

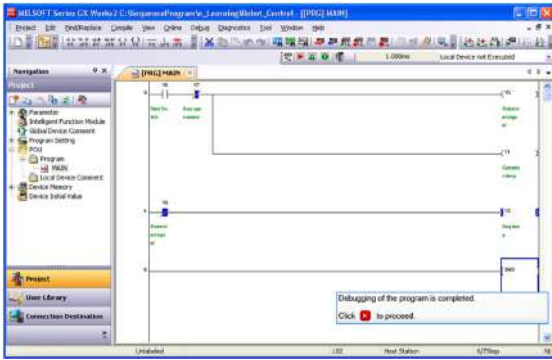

AUT310710 Programming Software for PC

Programming software IQ Works for programming of PLC from PC including USB cable.



ORDER DETAILS MOTOR CONTROL SYSTEM INCL. PLC

Product no	Description	Pcs	Page
ELE 102000	Base Unit 2000	1	145
AUT302000	PLC Module for Base Unit 2000	1	146
AUT302001	Simulation Module	1	146
AUT302002	Traffic Lights Module	1	146
AUT302003	Cylinder Module	1	147
AUT302004	Terminal Block Module	1	147
AUT302005	Ball Selection Module	1	147
Programming Tools when using PC			
AUT310710	IQ Works Programming Software for PC	1	148
Books			
BOK320030	Introduction to PLC	1	148
BOK312002	PLC Programming, Laboratory Exercises	1	148

Ref. 419

Automatic Sectional Door Model

The Automatic Sectional Door package offers a good training in control technology and automation. The course starts with basic exercises on logical functions with relays up to more advanced PLC - exercises. A complete laboratory package includes:

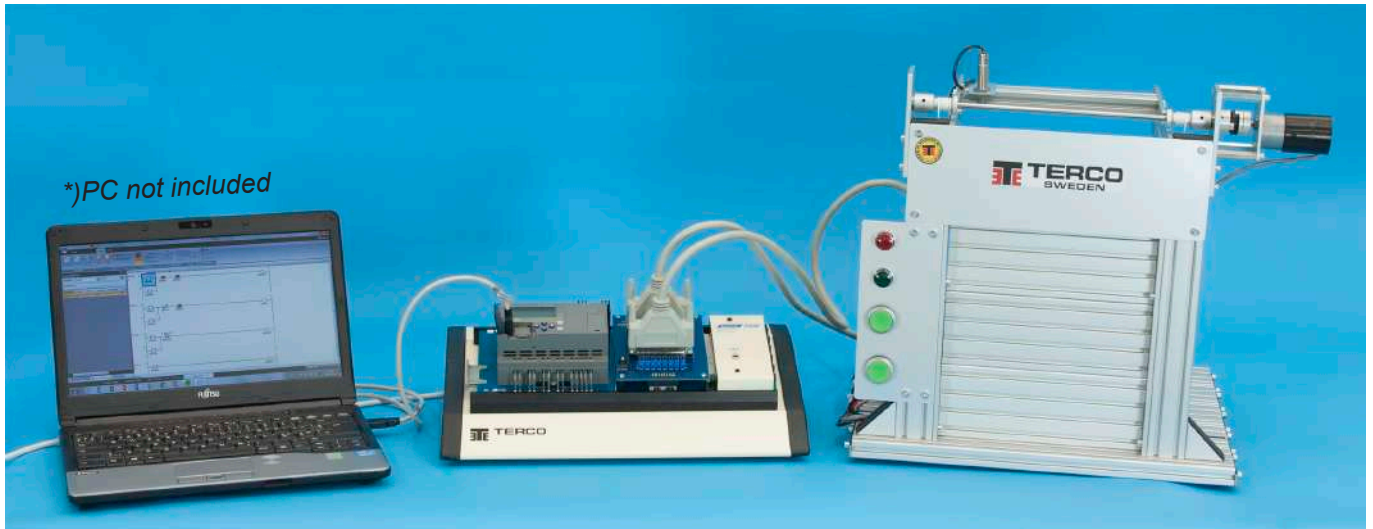

AUT309905-M Automatic Sectional Door Model

The Door is a miniature of a garage door. It consists of a roller shutter which can be hoisted up and down by means of a motor coupled to a cable system. The garage door can be controlled by either a rely-based control system or PLC. You can study start-stop functions, logical functions sequence and timing etc. Inductive sensors are used as limit switches. Other sensors can of course be used as optional.

The garage door is moved up and down by a DC - motor. It can be controlled manually by the push-buttons on the door side or with the switches on the Control Panel AUT309907 which is needed for both exercises. It can also be controlled by a PLC e.g. AUT302020 via either labflexes or cables with D-sub contacts.

For these experiments the socket Module AUT302008 plus D-sub Module AUT309906 or D-sub / Sim Module AUT309908 are needed.

The laboratory exercises comprises various labs where you get to test a number of logical functions and how you gradually build up different controls of the door.

Dimension: 500 x 400 x 430 mm
Weight: 8 kg

The laboratory package consist of:

- Automatic Sectional Door Model
- Control Module
- D-sub / Socket Module
- D-sub / Sim Module
- Socket Module
- Simulation Module
- PLC Module
- Base Unit 2000

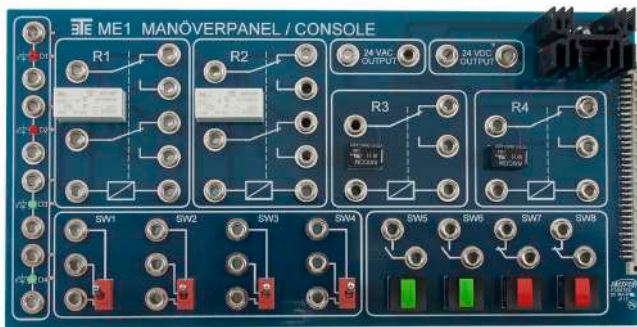

AUT309907 Control Module ME1

This Control Module contains components for doing basic experiments with relays, switches and LED's. ME1 is to be placed in slots of the Base Unit 2000 and automatically powered via a 32-pole D-sub connector. ME1 has following components:

- 4 pcs switching relays 24V DC
- 4 pcs toggle switches
- 4 pcs LED's
- 4 pcs pushbuttons

Dimension: 280 x 140 x 50 mm

Weight: 0.4 kg



AUT309906 D-sub/Socket Module ME2

With this module it is possible to connect the inputs and outputs of the Automatic Door Model to 4mm lab flexes. It contains:

- 16 sockets (4 mm)
- 2 D-sub contacts
- 2 sockets for power supply +24V DC

Dimension: 175 x 65 x 50 mm

Weight: 0.15 kg



USB Programming Cable for Mitsubishi Melsec FX Series PLCs,



AUT 302000 PLC Module

The PLC - Module has to be connected to the Base Unit 2000. To program a PLC a PC is connected to a programming port via a cable.

Alternatively a PC software may be used for programming. The PLC-module contains a PLC-system with sockets to connect any chosen module card. For the sockets there are several switches to simulate faults at the different in- and outputs.

General data

Mitsubishi Melsec FX3s DS PLC (24 V)

8 inputs and 6 outputs

Input and output of the PLC is connected to a 20 pin socket

Dimensions: 240 x 140 x 55 mm

Weight: 0.5 kg

AUT302008 Socket Module

The Socket Module is to be connected to the PLC-Module. The PLC-Module together with this socket Module will be used for 4 mm connections to the Automatic Door Model.

4 Toggle switches

Dimension: 100 x 140 x 45 mm

Weight: 0.1 kg





AUT309908 D-sub / Sim Module

With the D-sub / Sim Module, you can either simulate your program function using the switches or connect to your process model using the 37-pol D-sub contacts. Two cables are included.

The Module contains:

- 2 D-sub contacts
- 6 LED's (Y0 - Y5)
- 8 Switches (X0 - X7)

Dimension: 100 x 140 x 30 mm (only the card)

Weight: 0.6 kg (incl. the cables)



AUT302001 Simulation Module

The output signal levels can be altered using the Simulation Module that is plugged into the sockets of the PLC Module.

The 6 LED's shows output status and has input signals simulated by the 8 on/off switches.

Dimension: 100 x 140 x 40 mm

Weight: 0.1 kg

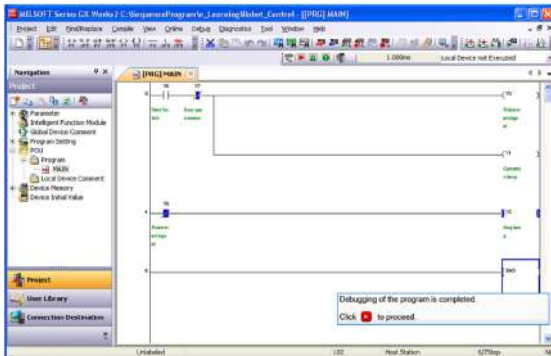

AUT310710 Programming Software for PC

Programming software IQ Works for programming of PLC from PC including USB cable.

ORDER DETAILS MECHATRONICS, AUTOMATIC DOOR MODEL

Product no	Description	Pcs	Page
AUT309905-M	Automatic Sectional Door Model	1	149
AUT309907	ME1 Console	1	150
AUT309906	M2 Socket Module	1	150
AUT302000	PLC Module for Base Unit 2000	1	150
AUT302008	Socket Module	1	150
AUT309908	D-Sub / Sim Module	1	151
AUT302001	Simulation Module	1	151
Programming Tools when using PC			
AUT310710	IQ Works Programming Software for PC	1	151
Base Unit with Power supply			
ELE102000	Base Unit 2000	1	145
Optional			
ELE102002	Storage Rack 1 row	1	196

Elevator Model



AUT300080 Lift Model

This Elevator Model is intended as a control object for programming exercises with a control system, PLC or computer. The process consists of a lift cage to be moved between four levels. The pushbuttons at each level and inside the lift cage have LEDs for indication.

General Data

Power supply: 24V DC
 Inputs: 10
 Outputs: 12
 LEDs: 8 (acknowledgement)
 Position sensors: 4 levels
 1 Lift minimum
 1 Lift maximum
 Logic level: 24 V DC
 Connection: Via terminal block or two 37 - pin D - connectors for quick connection to I/O Module
 Dimensions: 340 x 405 x 650 mm
 Weight: 9 Kg

Rear side of Lift Model

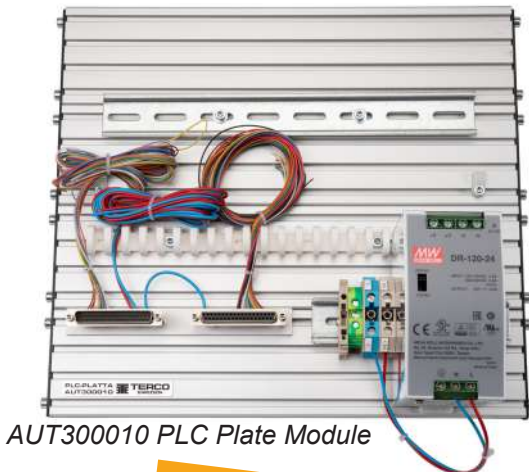

AUT300010 PLC Plate Module

AUT300010 PLC Plate Module

PLC mounting profile with pre-mounted DIN rail and terminals incl. 28-pin D-sub male and female contact. Optional PLC can be mounted.

Dimension: 320x360x 100 mm
 Weight: 3.2 kg



ORDER DETAILS LIFT

Product no	Description	Pcs	Page
AUT300080	Lift Model - Elevator	1	152
AUT302000	PLC Plate Module	1	152
AUT302000	PLC Module for Base Unit 2000	1	152
Programming Tools when using PC			
AUT310710	IQ Works Programming Software for PC	1	151
Books			
BOK110120	Lift Model, Laboratory Exercises	1	152
BOK320030	Introduction to PLC	1	152

Mecha-Kit System

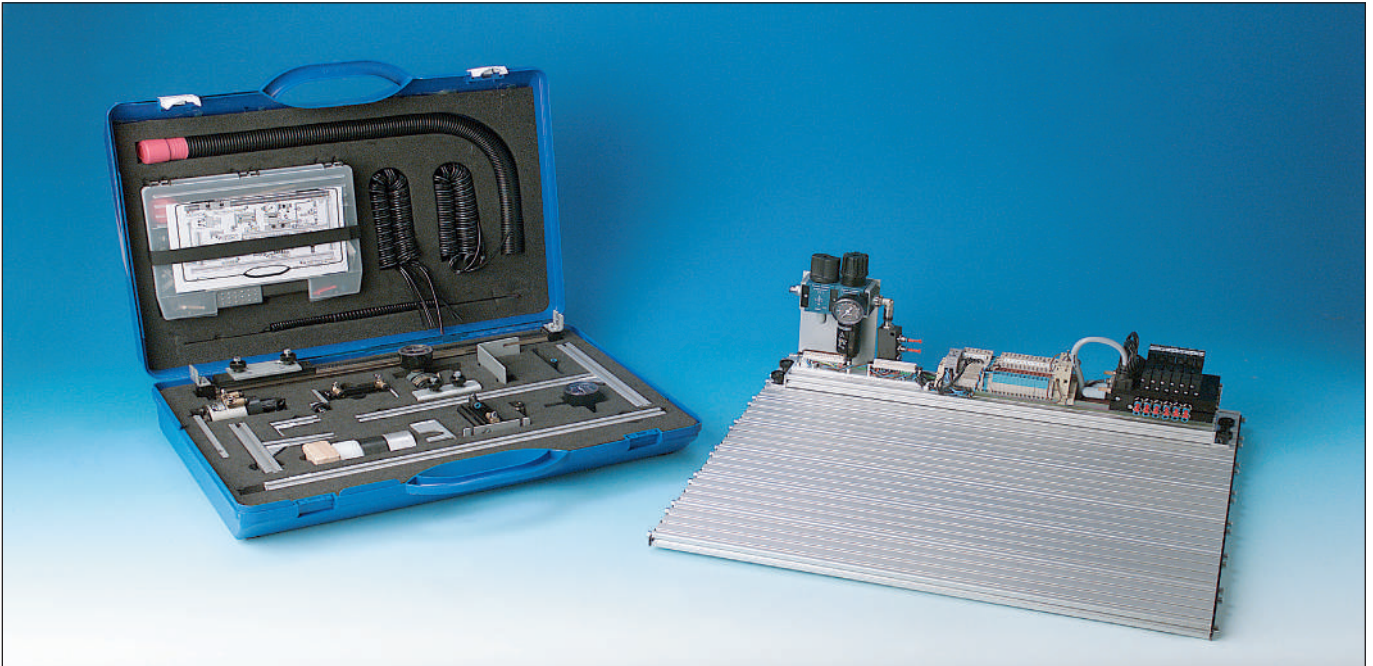

AUT300200 Mecha-Kit

Terco Mecha-Kit is a modular system for education in pneumatic and control techniques, known today as Mechatronics.

The Kit consists of an Aluminum base plate and a hard case, and a plastic box containing a number of different components within the field of Mechanics, Electronics, and Pneumatics.

With the Kit the students can build a number of simple automatically controlled handling units where only the imagination of the students sets the limit.

All electrical wiring and pneumatic circuitry work is done by the students.

The combination of direct hands on training and almost unlimited possibilities, inspire the students and quickly increases their interest in this kind of engineering. Most of the handling units can be linked to a PLC unit for automated control.

The units can be linked together and form a network and simulate a flexible manufacturing cell.

Mecha-Kit components are contained in a hard shell hand box which is easy to carry and easy to stow away.

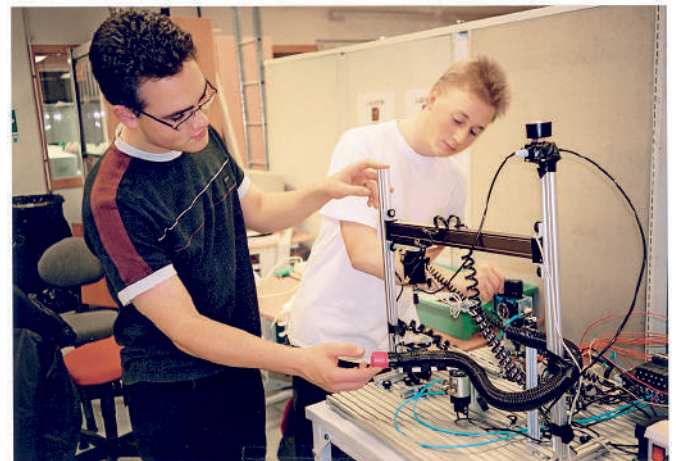

General Data:

Operating Voltage 24V DC +/- 10%
Working Pressure 5-7 bars

Dimension: 600 x 590 x 220 mm
Weight: 17.5 kg

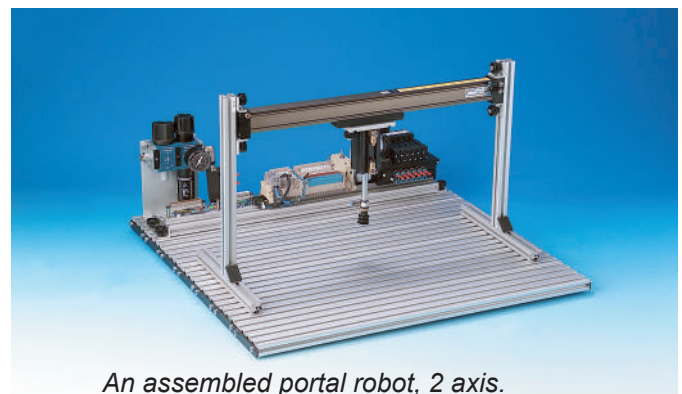

An assembled portal robot, 2 axis.

List of components in Mecha-Kit system

Profile System

- 1 Base plate with carrier handle, 600 x 560 mm, no. 1
- 1 Assembly bracket, low angle and two mounting screws, no. 2
- 1 Assembly bracket, high angle and two mounting screws, no. 3
- 2 T-profile, long angle and two mounting screws, nos. 4 and 5
- 1 T-profile, smaller, no. 6
- 1 Frame profile, larger, length 506 mm, no. 7
- 1 Frame profile, larger, length 467 mm, no. 8
- 1 Frame profile, smaller, length 150 mm, no. 9
- 1 Frame profile, short, length 55 mm, with T-groove mounting, no. 10
- 1 Short tube for suction plug, no. 11
- 1 Long tube for suction plug, no. 12
- 6 T-groove mountings for profiles
- 12 Mounting nuts, round, with plastic
- 1 Mounting for sensors, no. 13

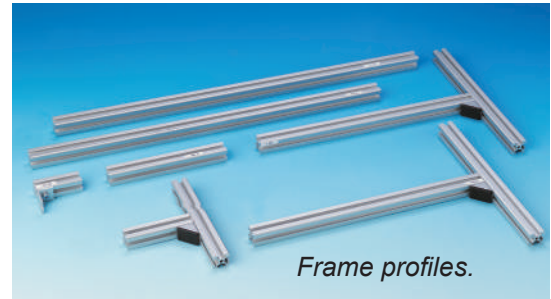

Pneumatic and Electrical Components

- 1 Air handling unit 1/4" conn. with shut-off valve, filter, pressure regulator and pressure gauge
- 1 Manifold lock, with connections
- 1 Pressure regulator with pressure gauge and non-return throttle valve
- 1 Double-acting cylinder, Ø 20 mm, stroke 40 mm, complete with mounting plate and mounting nuts
- 1 Double-acting cylinder, Ø 20 mm, stroke 50 mm, complete with mounting plate
- 1 Swivel device with 180° swivel, complete with mounting bracket, rotary arm and two PNP sensors
- 1 Shuttle cylinder Ø 16 mm, stroke 300 mm, complete with subplate and mounting brackets
- 8 Variable non-return throttle valves, mounted on all cylinder ports
- 1 Valve unit comprising six unistable valves, electrical control with spring return
- 1 Manifold block, electrical with starter button
- 6 PNP sensors, 3-wire
- 1 Vacuum monitor sensor
- 1 Ejector, complete with vacuum gauge
- 1 Plastic ejector, complete with connections
- 1 Suction pad with nipple
- 1 Suction pad, bellows type
- 1 Main air supply valve

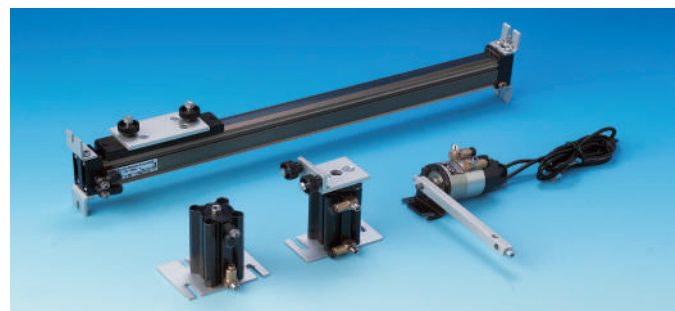
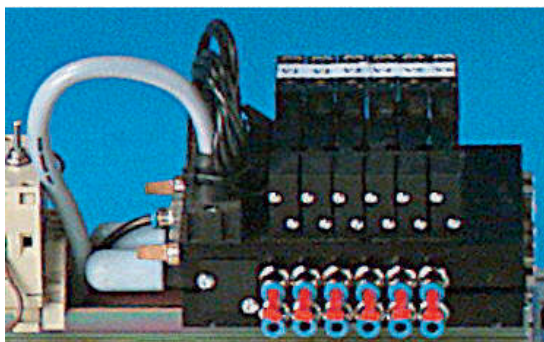



Other components included

- 1 Plastic storage box, 250 x 205 x 40 mm
- 2 Mountings for ball conveyor
- 1 Ball conveyor, 600 mm
- 1 Plastic cup, red Ø 35 x 15 mm
- 3 Pucks Ø 50 mm, height 30 mm, white, black and metallic
- 1 Square, 50 mm side, height 30 mm.
- 4 Wooden balls Ø 22 mm
- 1 Ball socket
- 5 Straight connection leads for sensors, 1 m
- 3 Angle connection leads for sensors, 1 m
- 4 Sensor mountings with double-acting cylinders
- 3 Sensor mountings for shuttle cylinder (painted red)
- 1 Dismantling fork
- 1 Plastic tube 4 mm, 5 m
- 1 Spiral hose, one of each single, double, triple 4 mm
- 1 Plastic tube clipper
- 2 Plastic mountings for cable and sensors
- 1 Screwdriver
- 1 8mm spanner
- 3 Hexagon (Allen) keys, 2 mm, 3 mm, 4 mm
- 2 T-coupling Ø 4 mm
- 10 Plugs Ø 4 mm
- 1 Tote box for profile systems and components, with inlay and mounting for tube and spiral hose, 530 x 385 x 120 mm

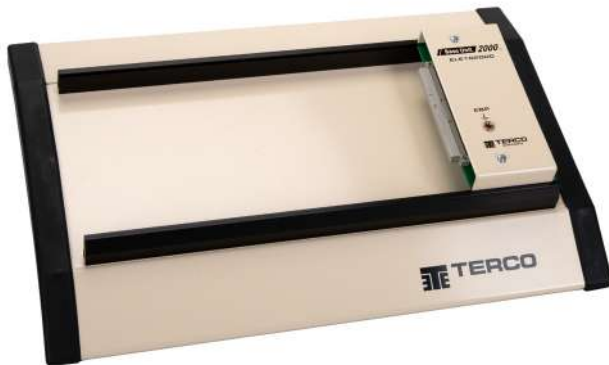

Other supply voltages available on request.

ELE102000 Base Unit 2000

The starting point of this laboratory system is Base Unit 2000, a control panel and PCB-holder.

The Base Unit can be loaded with laboratory cards which have been carefully designed to suit each particular area of study.

The Lab Cards are placed in slots and are automatically powered via a D-sub connector.

General Data:

Supply voltage 220-240V 50-60Hz 1-phase.

The unit has 6 outputs with following data:

Outputs 1-3: DC 12V / 3A with LED indication and fuse.

Outputs 4-6: AC 24V / 3A with LED indication and fuse.

Dimension: 370 x 180 x 75 mm.

Weight: 4 kg

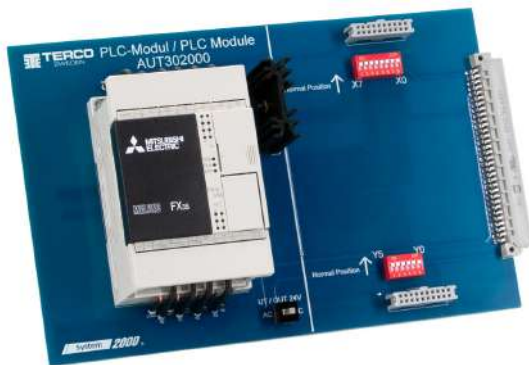

USB Programming Cable for Mitsubishi Melsec FX Series PLCs,



AUT302000 PLC Module

The PLC - Module has to be connected to the Base Unit 2000. To program a PLC a PC is connected to a programming port via a cable. Alternatively a PC software may be used for programming.

The PLC-module contains a PLC-system with sockets to connect any chosen module card. For the sockets there are several switches to simulate faults at the different in- and outputs.

General data

Mitsubishi Melsec FX3s DS PLC (24 V)

8 inputs and 6 outputs

Input and output of the PLC is connected to a 20 pin socket.

Dimensions: 240 x 140 x 55 mm

Weight: 0.5 kg



AUT302001 Simulation Module

The output signal levels can be altered using the Simulation Module that is plugged into the sockets of the PLC Module.

Shows output status with 6 LED's and has input signals simulated by 8 on/off switches.

Dimension: 100 x 140 x 40 mm

Weight: 0.1 kg

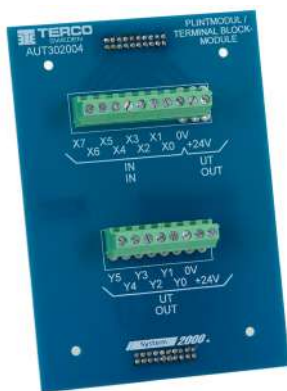

AUT302004 Terminal Block Module

The Terminal Block Module is to be connected to the PLC-Module. The PLC-Module together with the the Terminal Block Module will be used for connections to the Ball Selection Module. The connections will be made with one wire to each output and input.

In this case there will be 8 inputs and 6 outputs for control of the valves (for the cylinders), and sensors on the Ball Selection Module.

Conection between PLC and Lab Equipment

Dimension: 100 x 140 x 40 mm

Weight: 0.1 kg



AUT302002 Traffic Lights Module

The Traffic Lights Module is to be connected to the PLC Module. The Module simulates a traffic crossing for cars and pedestrians at a pedestrian crossing.

When experimenting with the Traffic Module, the student has the task of creating a PLC program to control the traffic lights.

There are red and green lights for the pedestrian crossing, and red, yellow and green for the vehicle traffic.

Dimension: 100 x 140 x 40 mm

Weight: 0.1 kg

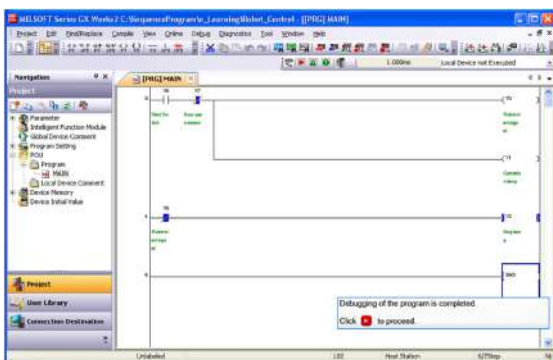

AUT310710 Programming Software for PC

Programming software IQ Works for programming of PLC from PC including USB cable.

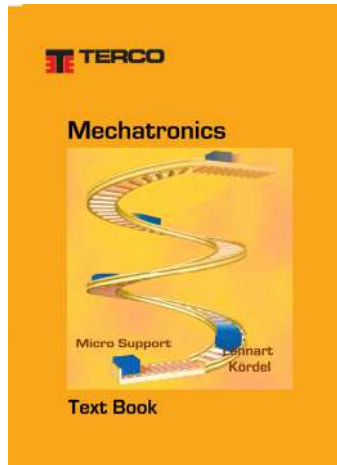

BOK300201 Text Book

Contents:

- What is Automation
- Actuators
- Valves
- Grippers
- Sensors
- Control systems
- Automation units
- Hints on commissioning and fault finding
- For practical training we have a laboratory exercise book.



BOK300200 Laboratory Exercise Book

Contents:

- Equipment explanation
- Cylinder power, setting force
- Deceleration, setting speed and deceleration
- Vacuum, use vacuum to grip
- Measuring fixture
- Pick and Place robot with short movements
- Pick and Place with rotation
- Linear movements
- Assembly station
- Hoist
- Pick and Place with shuttle, rotation device and cylinder
- Self-constructed Pick and Place

ORDER DETAILS MECHA-KIT SYSTEM INCL. BASIC PLC-SYSTEM

Product no	Description	Pcs	Page
Lab. Equipment			
AUT300200	AU5900 Mecha-Kit Modular System	1	153
ELE102000	Base Unit 2000	1	155
AUT302000	PLC Module for Base Unit 2000	1	155
AUT302001	Simulation Module	1	156
AUT302004	Terminal Block Module	1	156
AUT302002	Traffic Lights Module	1	156
Programming Tools when using PC			
AUT310710	IQ Works Programming Software for PC	1	156
Books			
BOK300200	Laboratory Exercise Book	1	157
BOK300201	MECHA-Kit, Text book	1	157
BOK300202	MECHA-Kit, Laboratory Exercises	1	
BOK312002	PLC Programming, Laboratory Exercises	1	
BOK320030	Introduction to PLC	1	
Optional (One Unit only)			
MT0415	Compressor	1	199

Ref.421

Section 10

Automotive Electronics



Two steps to teach modern vehicle electronics

TERCO Automotive Electronics has been divided into two educational stages:

Automotive Step One which covers basic electricity and electronics and is a training package for the basics of automotive electronics.

Training equipment makes it possible to create a simple learning situation, minimize the connection and measurement errors, and above all the time to complete all phases of the course in the time available.

The training package is built around power a base unit, which contains the power supply and is holder of the power adapter and the various lab-cards.

Automotive Step Two shows how different things happen in a vehicle by sending signals on two wires. To demonstrate this, there are two circuit boards that represent the dashboard and a car module for illumination and door closing. PCB dashboard each model are respectively coupled to the CPU.

Between CPUs go signals on the two wires (CAN-BUS) for various indications and actions.

A "fault finding unit" placed between CPUs makes it possible to learn the errors that may occur.

Automotive Step One



FOR102000 Base Unit

The power unit contains a power supply and is holder of the power adapter and the various lab cards. Power base unit can also be used to all other lab cards in the System 2000 series.

Mains: 230V / 50Hz
 Power Supply: 12V AC and DC, 8A
 Dimension: 376x215x355 mm
 Weight: 7.8 kg



FOR102001 ES1 Series Connection

By connecting a number of lamps in series in different ways the student can study the current and the voltage across each lamp.

Dimension: 240x50x140 mm
 Weight: 0.3 kg



FOR102002 ES2 Parallel connection

By connecting a number of lamps in parallel in different ways the student can study the voltage and the current through each lamp.

Dimension: 240x50x140 mm
 Weight: 0.3 kg

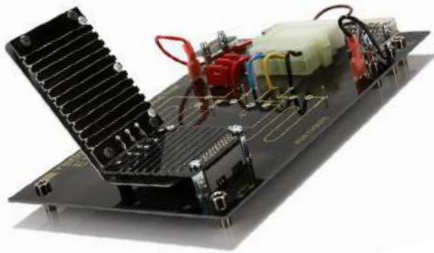

FOR102003 Heating chair

The student studies the current and voltage and the heat that arises. If a heating coil fails, the effect can be so great that a fire occurs. Current and voltage generate heat, sometimes with fire as a result. The exercises show what happens when transferring to the ground, short-circuiting and interrupting and treating the concept of power.

Dimension: 240x95x140 mm
Weight: 0.3 kg



FOR102004 ES4 Inductive Sensor.

This card consists of an inductive sensor and a toothed wheel driven by an electric motor with two different speeds. Speed by switched using a switch. The inductive sensor is an important component in automotive electronics. It is appropriate to use both multimeter and oscilloscope.

Dimension: 240x80x140 mm
Weight: 0.3 kg



FOR102005 ES5 Hall Sensor.

An electric motor drives a rotor gap where a Hall sensor is placed. Two different speeds can be obtained by means of switches. Measurement done with the oscilloscope.

Dimension: 240x65x140 mm
Weight: 0.3 kg



FOR102006 ES6 Relay

The card contains a closing relay, the opening relay and 3 lamp holder. The lamp holder can use bulbs with different power.

Dimension: 260x55x140 mm
Weight: 0.3 kg



FOR102007 ES7 Electronic Power Control PWM

With electronic control effect can continually be adjusted with pulse width modulation. The losses will be minimal compared to control using resistor.

The technique of varying the pulse width of the pulsating DC voltage is used in many applications in vehicles.

Dimension: 240x36x140 mm
Weight: 0.3 kg

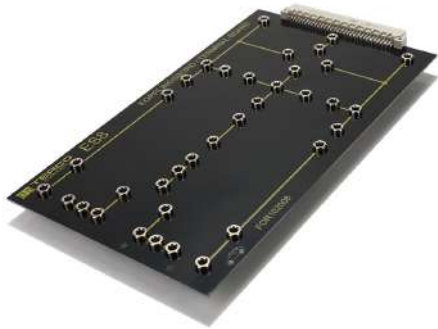

FOR102008 ES8 Terminal Board

The card consists of a number of 4mm connection socket where you can connect components contained in kit component (plug-in components). There are a number of exercises using components which are common in vehicles.

Dimension: 260x18x140 mm

Weight: 0.3 kg



FOR102010 ES10 Demister

The card is an example of an electrically heated car window. Because the card has a smaller area than a normal car window it uses a lower voltage at the trials so that no overheating occurs.

Dimension: 260x42x140 mm

Weight: 0.2 kg



FOR102009 ES9 Additional Power Supply

12V AC and DC

Dimension: 130x18x140 mm

Weight: 0.1 kg



FOR102011 ES11 Component Kit

Component kit for coupling table ES8. The Component kit contains various electrical and electronics components:

- Resistors
- PTC and NTC resistors
- Capacitors
- Diodes
- Transistors
- Switches
- Coil with an iron core
- Lamps
- Wires

Dimension: 335x50x255 mm

Weight: 1.3 kg

Automotive Step Two - Lab Base V2



The equipment provides an easy way to visualize communication with CAN-BUS. With the two ES35 control boxes, coupled with the driver's function card (dashboard) and the car's exterior (car model), the communication becomes clear and easy to access.

With the PC-CAN view software, you can watch the data packets sent via the CAN bus communication and thus see how the information differs when activating, for example, the direction and direction indicators right and left. You can also send signals from the software to the control box, thus activating functions.

The two function cards have expansion locations where sensors and actuators can be connected to get additional features to work with. Each expansion card has its own address, which means that the ES35 control box recognizes which card has been connected and communicates with the correct function on the receiving device.

The CAN bus signal can be sent via a fault simulation box where 8 different electrical errors can be advanced via buttons on the panel. Examples of common errors that can be generated:

- Short circuit between CAN H and CAN L
- Short circuit between CAN H and +
- CAN H interruption
- Incorrect resistance in termination

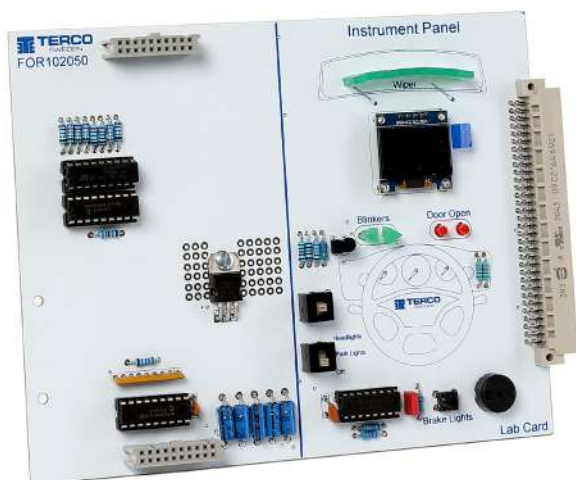

FOR102050 Instrument panel with expansion site

- Switch for parking lights, dipped beam, blinkers and brake lights
- Indicator of blinker / solved door
- Display for displaying messages
- Diodes for simulation of windscreen wipers (rain sensor)

Dimension: 175x140x20mm
Weight: 0.3 kg

Terco reserves the right to make changes in the design and modifications or improvements of the products at any time without incurring any obligations

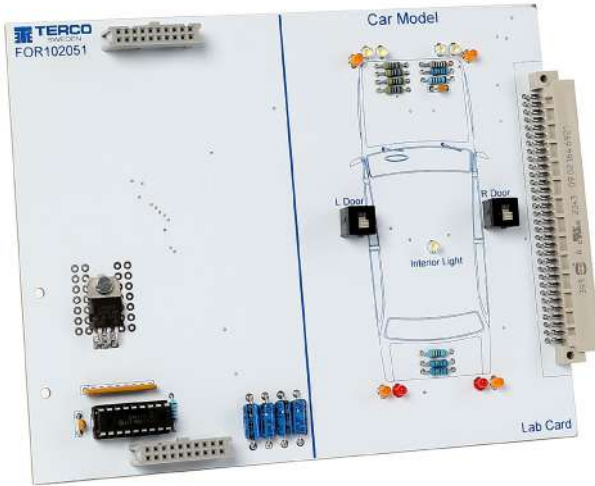

FOR102051 Car model with expansion site

- Indicator for interior lighting, headlights, tail lights, brake lights and blinkers
- Indication of open door

Dimension: 175x140x20 mm

Weight: 0.3 kg



FOR102061 Parking Sensor

With ultrasound, transmitter and receiver, Indicates distance to obstacles on the dashboard display.

Active distance is 3 - 50cm, at distances less than 30cm, an audio signal is also activated.

Dimension: 88x140x20 mm

Weight: 0.2 kg



FOR102062 Gear Indicator

With the help of hall sensor it is indicated on the display in which mode the gear selector is.

Dimension: 88x140x20 mm

Weight: 0.2 kg



FOR102063 Touch Sensor

2 capacitive sensors, which in this case indicate that the hand approaches the door and unlocks. (In reality, this is combined with signal from the start key.)

Dimension: 88x140x20 mm

Weight: 0.2 kg



FOR102064 Rain sensor

IR sensors detect moisture and via the CAN box activates the windscreen wipers.

Dimension: 88x140x20 and 45x45x20 mm

Weight: 0.3 kg

ORDER SPECIFICATION AUTOMOTIVE ELECTRONICS PART 1

Order code	Description	Pcs	page
FOR102000	Base Unit	1	159
FOR102101	ES1 Series connection	1	159
FOR102002	ES2 Parallel connection	1	159
FOR102004	ES4 Inductive Sensor	1	160
FOR102005	ES5 Hall Sensor	1	160
FOR102006	ES6 Relay	1	160
FOR102007	ES7 Electronic Power Control PWM	1	160
FOR102008	ES8 Terminal Board	1	160
FOR102009	ES9 Additional Power Supply	1	161
FOR102010	ES10 Demister	1	161
FOR102011	ES11 Component Kit	1	161
ELE102004	Storage rack 2-row	1	196
MAT220575	Handscope 20MHz incl. software	1	190
MAT2200118	Digital Multimeter	1	191
	Exercises part 1 CAN-BUS Basic.	1	

ORDER SPECIFICATION AUTOMOTIVE ELECTRONICS PART 2

Order code	Description	Pcs	page
FOR102000	Base Unit	1	159
FOR102055	Instrument panel with expansion site	1	162
FOR102060	Car Model with expansion site	1	163
FOR102061	Parking Sensor	1	163
FOR102062	Gear Indicator	1	163
FOR102063	Touch Sensor	1	163
FOR102064	Rain Sensor	1	164
MAT220575	Handscope 20MHz incl. software	1	190
MAT220118	Digital Multimeter	1	191

Ref.503

Terco reserves the right to make changes in the design and modifications or improvements of the products at any time without incurring any obligations

Material Testing Laboratory



In all industrial production, from the smallest parts in electronics to large bridge structures, it is important to design materials so that they withstand the stresses they are subjected to. TERCO's Material Testing Laboratory provides a basic knowledge for higher studies in materials engineering.

MT3005 Twist and Bend Testing Machine

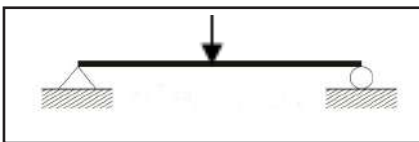
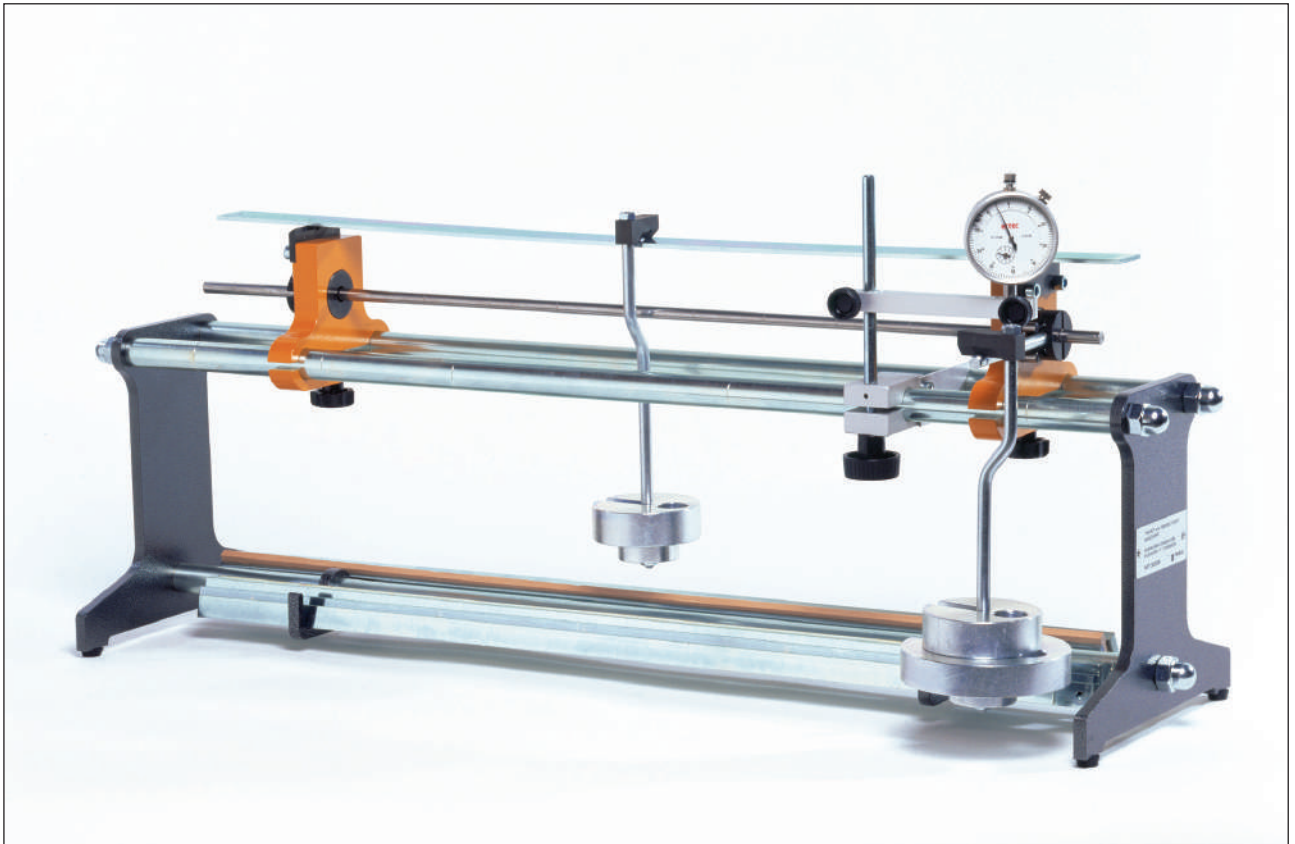

Freely supported in both ends

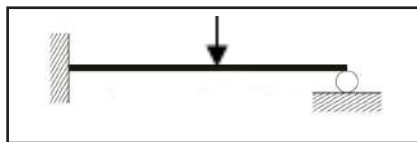

One end fixed and one end freely supported

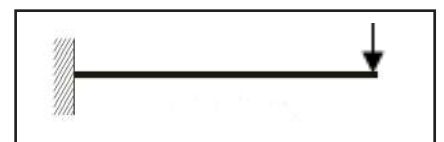

Freely supported in both ends

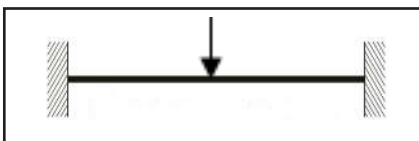

Both ends fixed

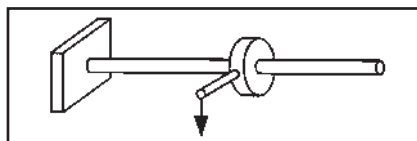

Twisting

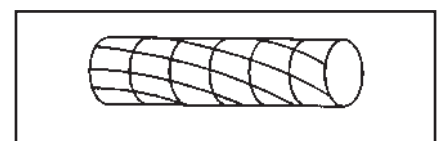

Twist diagram

MT3005 is a combined twist and bend testing machine. It can be used both in laboratory exercises, and in conjunction with theoretical work on twist and bending. Its size and weight makes it easy to carry between classrooms.

Twist

You use twist tests to determine and compare the modulus of rigidity for different materials and to demonstrate the deformation formula.

Bending

You use bending tests to determine the modulus of elasticity of different materials. You also use them to demonstrate, for example, the relation between load, moment of inertia, distance between supports, modulus of elasticity, and deflection.

The test pieces for bending tests are of different dimensions, so you can determine the relation between moment of inertia and dimension of a material.

Exemples of experiments

- Investigate the relationship between load, span, dimensions and deflection of a beam.
- Ascertain the coefficient of elasticity for steel, brass, Aluminum and wood.
- Investigate the relationship between the torsional moment, clamping length and torsional angle of a shaft.
- Determine the shear modulus of steel, brass, and Aluminum.
- Investigate the difference of having one end of the test piece fixed, both ends fixed, and no end fixed.

MT3005 comprises:

- Twist and Bend Testing Machine
- Two loading devices (0.25 Kg)
- Two 1 kg weights
- Four 0.5 kg weights
- One dial gauge
- Seven steel test pieces of rectangular cross-section
- One wood test piece of rectangular cross-section
- Three test pieces, diameter 8 mm, of resp. steel, Aluminum, and brass
- Two end fixtures
- Laboratory manual

Technical data		Dimensions	790x225x345 mm
Max distance between supports:	600 mm	Weight	13 kg
Accuracy of bending:	0.01 mm		
Accuracy of twisting:	0.01 mm (degrees)		

MT3004-E Strain Gauge Bridge with PC Interface



MT3004-E Strain Gauge Bridge

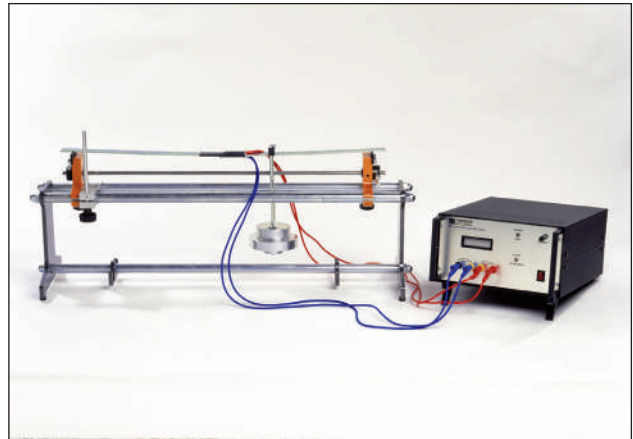

MT3004-E connected to MT3005

MT3004-E is a measuring bridge for the study of deflection and load variations, suitable for use in combination with the Twist and Bend Testing Machine MT3005 and the test pieces of steel and Aluminum. The two included test pieces are provided with two strain gauges (120 Ω) each, connecting cables and contacts. The gauges are protected against the ingress of moisture and against mechanical damage.

The measuring bridge is controlled by a microprocessor. The strain per unit of length (micro strain) is read directly on the instrument. The instrument has very high accuracy and can be used in connection with any strain gauge measurement provided the gauge factor value K is within 1.50 - 2.50. The equipment is equipped with interface for connection to PC and the necessary software is included in the delivery.

Software includes: Save measured data, graphic presentation, and calculations.

MT3004-E comprises

- Strain Gauge Bridge
- 2 test pieces with strain gauges (2 different steels)
- Connecting cables and contacts (4 mm)
- Manual
- Software

Technical data	
Self zeroing	
Adjustable Gauge Factor value	(1.5 < K > 2.5)
Range	+/- 2000 microstrain
Linearity	0.2 %
Accuracy	1 %
Supply Voltage	230 V 50/60 Hz (MT3004-E) 110 V 60 Hz (MT3004-E-116)
Dimensions	250 x 150 x 300 mm
Weight	2 Kg



Examples of experiments

MT3012-E comprises

- Fatigue Testing Machine
- Tool box containing all the necessary
- 5 test pieces of each (tot. 15 pcs)
- Computer Interface
- Laboratory manual

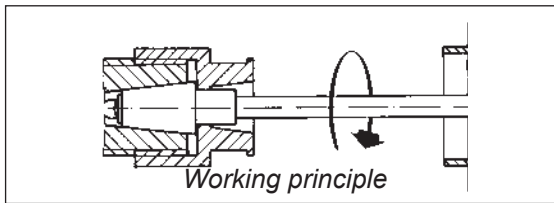

Test pieces steel	Qty	Radius of fillet	Surface smoothnes
1 (MT3026-1)	5	0.5 mm	4 μ
2 (MT3026-2)	5	2 mm	4 μ
3 (MT3026-3)	5	2 mm	25 μ

Optional:

Testpieces in aluminium and brass are available on request

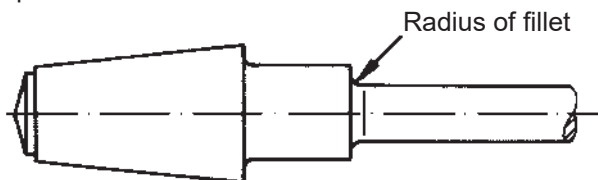

Technical data

Test piece diameter	8 mm
Max. load	255 N
Supply voltage	230V 50-60Hz (MT3012-E) 110V 60Hz (MT3012-E-116)
Speed (approx)	3000 rpm resp. 3600 rpm
Dimension	980x280x460 mm
Weight	24 kg

MT3012-E Fatigue Testing Machine

Rotary bending

With the varying load to which most machines are exposed it is not the static break point but the fatigue limit which decides when a fracture occurs. Fatigue strength is thus of very great significance in machine design.

MT3012-E provides a simple way of learning the effect of radius of fillet, surface smoothness, etc. on a material subjected to fluctuating flexural stresses. The machine is delivered with interface to PC and Software.

MT3012-E is driven by a 1-phase asynchronous motor. The number of load changes is read directly on the LCD-display as well as the applied force.

The tapered test pieces is attached to a very stable shaft in two spherical ball bearings.

The force is applied to the test piece with a spring and can be varied between 0 and 255 N

Test can be carried out with

- a) Fixed applied force
- b) Fixed deviation

By use of the front panel you can program the test to stop at certain preset values.

This ensure exact measurement and is of great advantage in experiments of a lengthy nature such as recording of a complete Wöhler curves.

By using the included software you can set all para-meters and start and stop the machine.

During the test the revolutions, force, limited force and real time diagram will be indicated on the screen.

The events will be recorded and can be printed.

The machine can be used with or without PC.

MT3012-E has a micro-processor which, on the fracture of the test piece, automatically switch-off the voltage to the motor via a relay. This ensures exact measurement and is of great advantage in experiments of a lengthy nature, such as the recording of complete Wöhler curves.

- Test the fatigue strength of a material subjected to changes in bending stress
- Investigate the effect of the radius of the fillet and surface smoothness
- Record a simple Wöhler diagram
- Determine a Wöhler diagram for different radii of fillet and for different materials

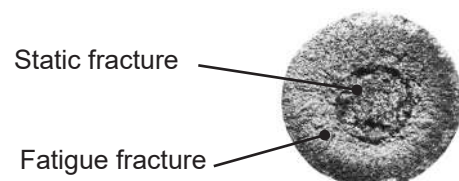

MT3016 Impact Tester



MT3016 Impact Tester

MT3016 is a robust, easily handled bench impact tester (Charpy) made to standard specifications. It demonstrates in a simple and reliable manner how the impact strength characteristics of a material are affected at, for example, low temperature. This is of great importance for the choice of material in applications subjected to heavy temperature fluctuations. It is also useful when a teacher wishes to demonstrate how the impact strength of a material is affected by different kinds of heat treatments, e.g. hardening, tempering, and normalizing. With MT3016 the student can do his laboratory exercises without difficulty.

Description

The machine has a heavy and stable cast iron mounting with holes for bench attachment. The stand consists of two robust steel bars. The pendulum is mounted in ball bearings and precision balanced. The test piece supports are hardened and ground. The distance between supports can easily be adjusted. The scale is graduated in joules and shows directly the energy required to break off the test piece. The pendulum is braked with a friction brake.

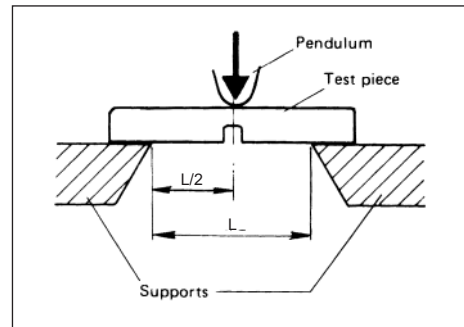
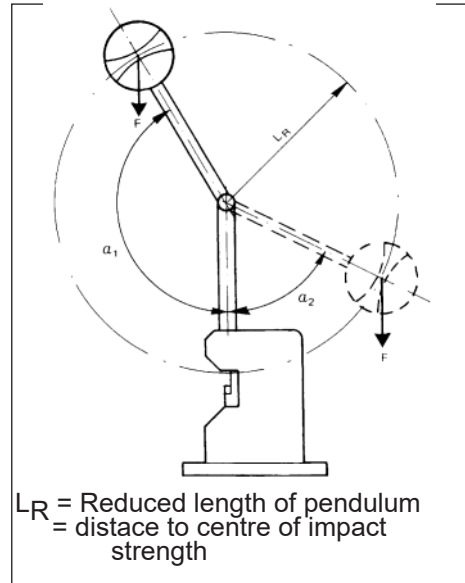

Examples of experiments

- Investigate the effect of carbon content on impact strength
- Investigate the effect of temperature on impact strength
- Investigate the effect of normalization on impact strength

MT3016 comprises:

- Impact Tester
- 5 test pieces of 3 different steel qualities (Tot 15 pieces)
- Laboratory Manual

Test pieces for MT3016

Product no	Impact Test Piece	Qty
MT3027-1	Construction Steel (red)	5
MT3027-2	Engineering Steel (yellow)	5
MT3027-3	Tooling Steel (green)	5

Technical data

Max. impact energy	15 joule (1 J= 1 Nm)
1 Scale graduation	0.1 joule
L_R	358 mm
Dimensions of test pieces	6x6x44 mm
Dimensions	170x290x615 mm
Weight	30 kg

Tensile, Compression and Brinell Testing



MT3017 Tensile and Brinell Testing Machine

Technical data

Maximum load	20 kN
Max movment of operating cylinder	Approx. 20mm
Dimensions	360x360x820 mm
Weight	24 kg

MT3017 Tensile and Brinell Testing Machine

is a hydraulic tensile testing machine with a screw-type operating cylinder which results in completely smooth and stepless loading.

The cylinder is operated by a crank designed so only light hand power is required to obtain maximum load. The pedagogic design of the machine allows the student to observe what is happening throughout the entire process. Its convenient size and sturdy structure make the MT3017 a highly reliable and safe machine. The power is shown on a large and clearly visible indicating instrument which is graduated in kN (kilo Newton). The instrument has a maximum value indicator on the test rod which shows the power at failure.

The extension is measured by a gauge with an accuracy of 0.01 mm.

The machine provides extremely fine tensile testing charts where the elastic range, the yield range, and the plastic range are clearly indicated.

The tensile test rods for the MT3017 are 5 mm in diameter with threaded ends. This makes them very easy to mount and also ensures reliable fastening.

The MT3017 can also be used for Brinell testing. A Brinell kit MT3019-3017 and measuring magnifier are included. This machine may also be used for bending and buckling tests.



Holders for Tensile Rods are Incl. in MT3017

MT3017 Tensile and Brinell Testing Machine comprises:

- Tensile Equipment

- MT3018 Test piece holders (standard model)
 - MT3018-1, Tensile Test Rods, steel - 5 pcs
 - MT3018-2, Tensile Test Rods, aluminum - 5 pcs
 - MT3018-3, Tensile Test Rods, brass - 5 pcs
 - MT3018-4, Tensile Test Rods, copper - 5 pcs

- Brinell Testing Set

- Steel ball intendor (10 mm)
- MT3019-1, Brinell Test Piece, steel - 5 pc
- MT3019-2, Brinell Test Piece, aluminum - 5 pc
- MT3019-3, Brinell Test Piece, brass - 5 pc
- MT3019-4, Brinell Test Piece, copper - 5 pc

- Laboaratory Manual and - Tool Box containing Sliding Caliper and above test pieces

MT3047 PC Measuring Device



MT3017 with MT3047 adapted.

both as tables and as diagrams. The diagrams can be printed. The kit is very easy to install and no drilling or machining is necessary. A user friendly installation description is included.

MT3047 is a kit of components designed to be adapted on the Terco Tensile Testing Machine MT3017. Together with a computer interface and dedicated software, (the same as for MT3037), all tests can be recorded by the computer and displayed

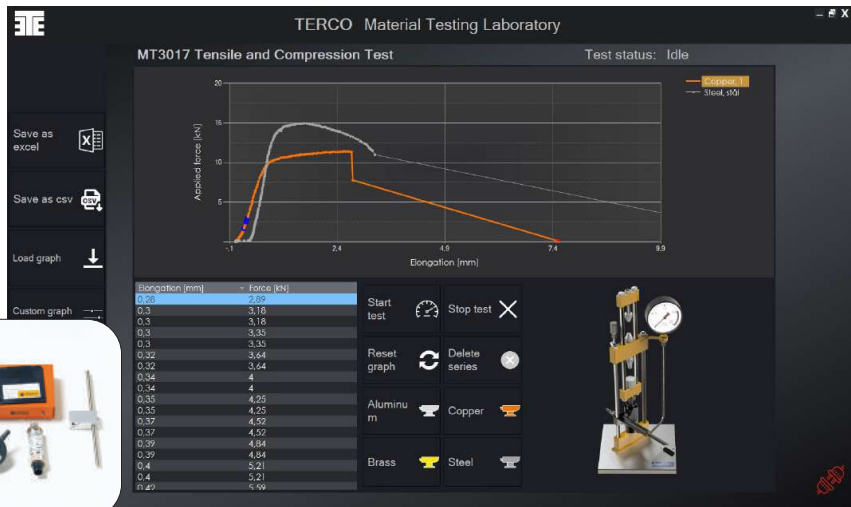

MT3047 comprises:

- Pressure transducer
- Digital dial gauge
- Computer interface
- Software
- Mounting details incl. cables
- Manual
- Adapter 230 V (MT3047) or 110V (MT3047-116)

Tensile diagrams for different materials

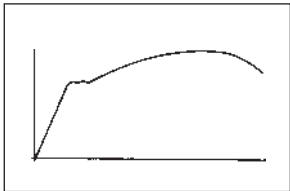

Steel

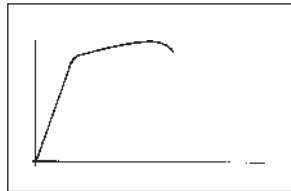

Aluminum

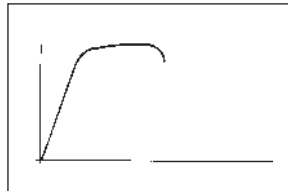

Brass

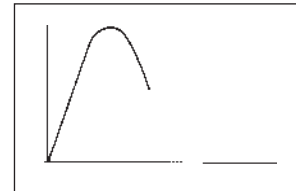

Copper

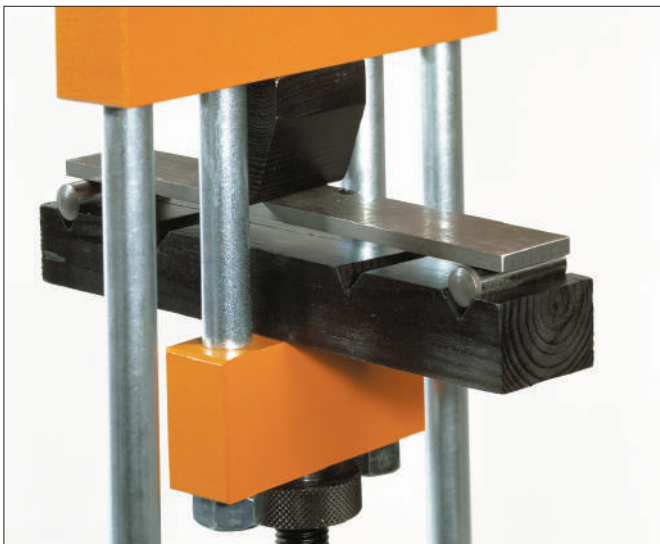

MT3007 Bending Test Set (optional)

MT3007 Terco Bending Test Set is an easy to use kit for bending tests, and can be used together with our Tensile Testing Machines MT3017.

The system consists of a study base profile of steel where two supports can be placed in four different fixed positions. The span width is varied between 100 and 200 mm.

The test set comprises:

- Holders
- Test piece of steel, length 250 mm, dim. 6x25 mm
- Test piece of steel, length 250 mm, dim. 6x35 mm
- Test piece of steel, length 250 mm, dim. 8x25 mm
- Test piece of steel, length 250 mm, dim. 10x25 mm

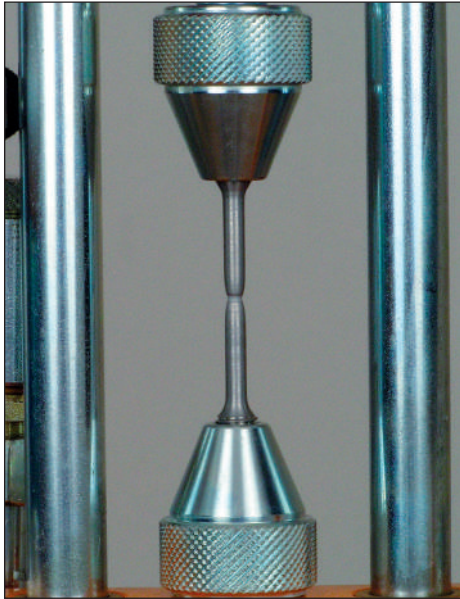

Tensile Test pieces

Separate orders of Tensile Test Rods

- MT3018-1, Tensile Test Rods, steel - 5 pcs
 - MT3018-2, Tensile Test Rods, aluminum - 5 pcs
 - MT3018-3, Tensile Test Rods, brass - 5 pcs
 - MT3018-4, Tensile Test Rods, copper - 5 pcs
- (Standard Tensile holders are incl. in MT3017)



Sets of Tensile Test Rods

MT3037-2 (optional) Clamping Jaws

To be used for testing of sheet material like metal sheet and plastics. It requires special designed test pieces to avoid breaking inside the jaws.

Test material is not included.

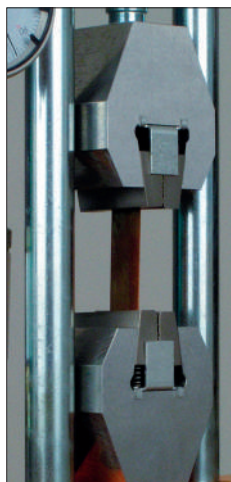

Brinell Test pieces

Separate orders of Tensile Test Pieces

- MT3019-1, Brinell Test Piece, steel - 5 pc
 - MT3019-2, Brinell Test Piece, aluminum - 5 pc
 - MT3019-3, Brinell Test Piece, brass - 5 pc
 - MT3019-4, Brinell Test Piece, copper - 5 pc
- (Standard Steel ball indenter 10 mm is incl in MT3017)

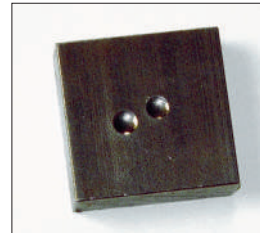

Brinell Test Piece
after Brinell Indent

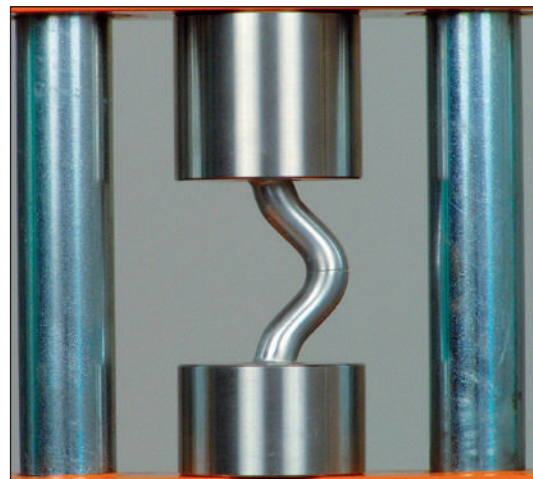

MT3037-3 (optional) Compression Test Set for MT3017

- MT3037 Compression test holders incl. Test Rods below

Separate orders of Compression Test Rods

- MT3017-51, 5 mm, steel - 5pcs
- MT3017-52, 5 mm, aluminum - 5pcs
- MT3017-53, 5 mm, brass - 5pcs
- MT3017-54, 5 mm, copper - 5pcs

Technical data

Maximum specimen thickness	2 mm
Max width of specimen	22 mm
Weight	1.5 kg

Terco Material Testing DAQ Interface

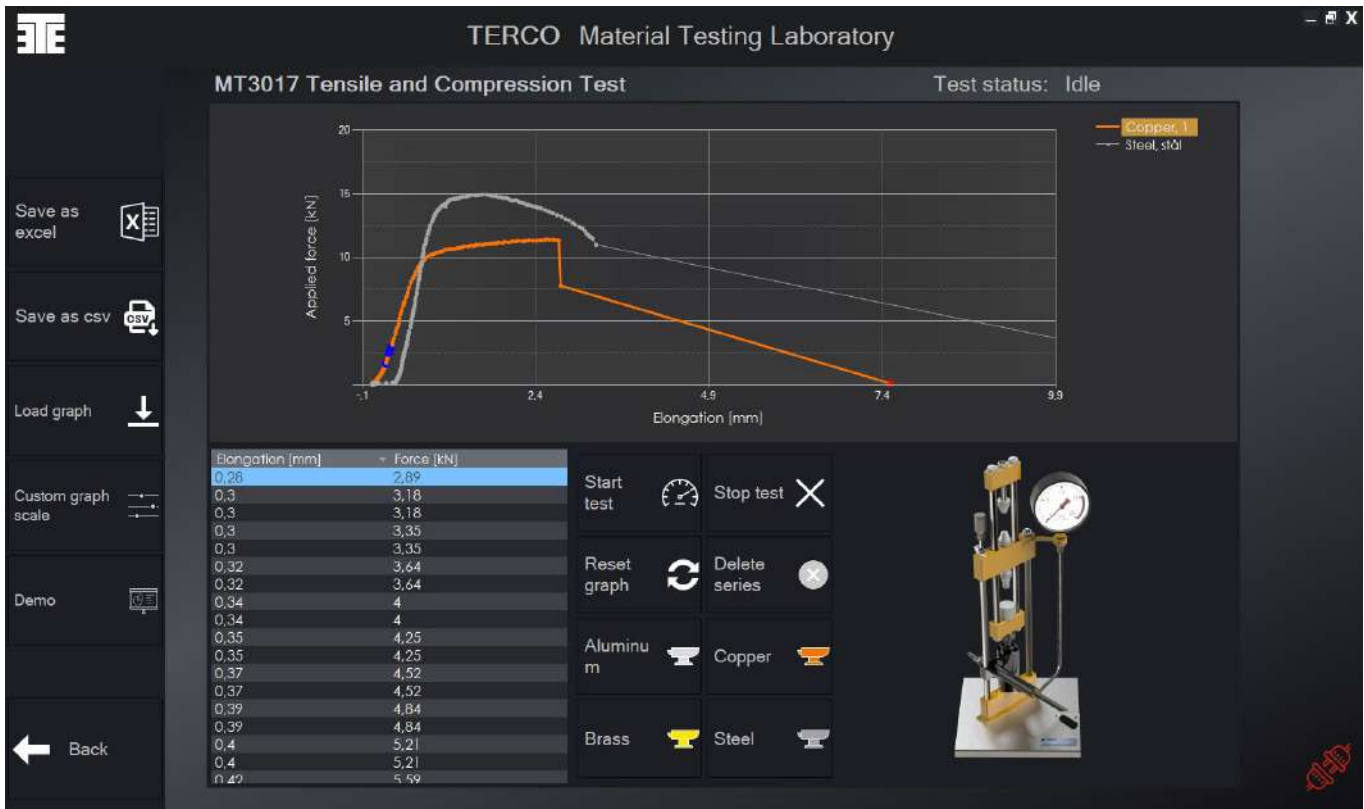

Terco Material Testing DAQ Interface is our new PC-Program for all our Material Testing Laboratories. Data, such as elongation and force are sampled during the experiment and shown on the screen. Compared to our old Program, this is a great update that supports Windows 10. Several graphs can be imported and shown on the screen and be exported to excel.

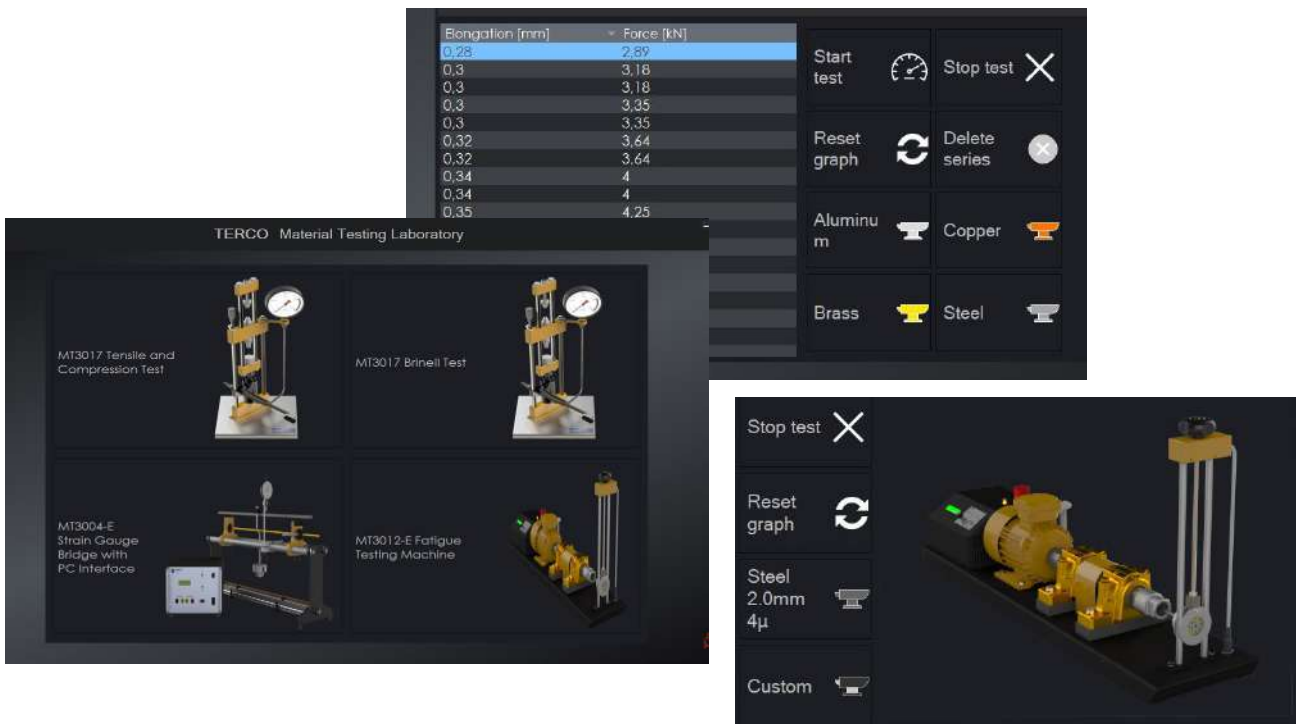

Terco reserves the right to make changes in the design and modifications or improvements of the products at any time without incurring any obligations

ORDER DETAILS MATERIAL TESTING LABORATORY			
Product no	Description	Pcs	Page
Twist and Bend Testing			
MT3005	Twist and Bend Test Machine Set	1	167
MT3004E	Strain Gauge Bridge, 220 V, 50 Hz	1	168
Fatigue Testing			
MT3012E	Fatigue Testing Machine, 220 V, 50 Hz	1	169
MT3026-1	Fatigue Test Piece, (5 pcs), 0,5 mm/4u	1	169
MT3026-2	Fatigue Test Piece, (5 pcs), 2 mm/4u	1	169
MT3026-3	Fatigue Test Piece, (5 pcs), 2 mm/25u	1	169
Impact Testing			
MT3016	Impact Tester	1	169
MT3027-1	Impact testpiece (construction steel) 5 pcs	1	169
MT3027-2	Impact testpiece (engineering steel) 5 pcs	1	169
MT3027-3	Impact Test Piece (tooling steel) 5 pcs	1	169
Tensile, Compression and Brinell Testing			
MT3017	Tensile and Brinell Test Machine incl Standard holders, Box with Slide Caliper, 40 test peices in different material for Tensile, Compression and Brinell Testing	1	171
Optional accessories for MT3017			
MT3047	PC Measuring Device for MT 3017	1	172
MT3007	Bending Test Set for MT3017 incl. test peices	1	172
MT3037-2	Clamping Jaws for test of thin material (Material not incl.)	1	173
MT3037-3	Compression Test Set incl. Holders and Test Rods	1	173
Test pieces for MT3017			
MT3018-1	Tensile set 5 pcs / steel diam. 5 mm	1	173
MT3018-2	Tensile set 5 pcs/aluminum diam. 5 mm	1	173
MT3018-3	Tensile set 5 pcs / brass diam. 5 mm	1	173
MT3018-4	Tensile set 5 pcs / copper diam. 5 mm	1	173
MT3019-1	Brinell Test Piece steel 5 pcs	1	173
MT3019-2	Brinell Test Piece aluminum 5 pcs	1	173
MT3019-3	Brinell Test Piece m brass 5 pcs	1	173
MT3019-4	Brinell Test Piece copper 5 pcs	1	173
MT3017-51	Compression Test Rods 5 mm, steel 5 pcs	1	173
MT3017-52	Compression Test Rods 5 mm, aluminum, 5 pcs	1	173
MT3017-53	Compression Test Rods 5 mm, brass, 5 pcs	1	173
MT3017-54	Compression Test Rods 5 mm, copper, 5 pcs	1	173
MTH 600	Brinell Hardness Tester	1	197

Ref.550

Power Supply and Generators





MV1304 Power Pack

As MV1300-415 but with the following data

Output voltage	DC fixed	220 V 3.5 A
	DC variable	0-220 V 16 A
	AC fixed	415 / 240 V 10 A 3-ph
	AC variable	3 x 0-415 V 10 A 3-ph
Supply voltage	415 / 240 V 50-60 Hz 3-ph	



MV1300 Power Pack

This power supply unit is especially adapted for laboratory experiments on electric machines and power systems. The contactor for variable voltages has a safety limit switch which eliminates switching on high voltages by mistake, thus protecting students and equipment especially when working on electrical machines. All outputs are fused by MCB's and have load switches. The Power Pack has also Earth Leakages Circuit Breaker (ELCB).

General Data

MV1300-235

Supply voltage 220-240/127-140V, 50/60Hz 3-ph.

MV1300-405

Supply voltage 380-400/220-230V, 50/60 Hz 3-ph.

MV1300-415

Supply voltage 415/240V 50/60 Hz3-ph.

Output voltage	DC fixed	220 V 3.5 A
	DC variable	0-220 V 16 A
	AC fixed	230/133 V 10 A 3-ph
	AC variable	3 x 0-230 V 10 A 3-ph
Standard	Fixed AC	230 V 10 A
Dimensions	660 x 435 x 790 mm	
Weight	103 kg	

MV1302 Power Pack

Same as MV 1300-405 but with the following data

Supply voltage 380-400/220-230V, 50/60 Hz 3-ph

Output voltage	DC fixed	220 V 3.5 A
	DC variable	0-220 V 16 A
	AC fixed	400 / 230 V 10 A 3-ph
	AC variable	3 x 0-400 V 8 A 3-ph

MV1103 Variable Transformer 3-phase

Supplied with a scale showing output voltage. Thermal overload protection for three output phases are placed on the front panel. A common shaft rotates all output voltage sliders in parallel. The unit is mobile on 4 wheels.

Input:	3 x 400 V, 8 A, 50-60 Hz
Output:	3 x 0-450 V, 8 A

Dimensions:	280 x 290 x 560 mm
Weight:	34 kg



Tachogenerators

The generator is mounted inside a protective guard. The cover is hinged and can be fixed by a locking screw.

MV1024 DC Generator

14 V at 1000 rpm (with trim potentiometer)

MV1025 DC Generator

14 V at 1000 rpm. (to be used with the MV1036 Electric Torque Meter System which has built-in trim potentiometer)

MV1029 Protective Cover (only)

Please note : The protective guard can be fitted between the machines to cover the rotating couplings, thus minimising the risk of accidents from rotating machinery.

Dimensions: 200 x 190 x 205 mm
Weight: 2 kg



MV1104 Variable Transformer Single Phase

The annular core of this variable transformer is of high alloy transformer sheet with small losses.

The contact point on the winding, which is wound for a constant current obtained throughout the entire range, is provided by a sliding carbon contact. Thermal overload protector.

Switch with pilot lamp. Rubber pedestals at the bottom and rear for convenient placing in the most suitable position at any time.

Input: 230 V, 50-60Hz
Output-max: 0-260 V, 8 A, 50-60 Hz, 4mm outlets
Dimensions: 200 x 190 x 205 mm
Weight: 9 kg

Important Notice - Explanation of Suffix

Suffixes indicating voltage and/or frequency ensure that equipment corresponds with the various voltages in different countries.

For DC-machines, all having 220 V supply, the suffix indicates different to match synchronous speeds, speeds alternatively 50 or 60 Hz, when DC and AC machines are coupled together.

Examples of codes involved:

Torque Meter DC-Machines:

MV1036-225 DC-machine Torque Meter (analogue), Voltage 220 V 50 Hz
Rated speed: Generator 1500 rpm, Motor 1400 rpm
MV1036-226 DC-Machine Torque Meter (analogue), Voltage 220 V, 60 Hz
Rated speed: Generator 1800 rpm, Motor 1700 rpm

DC machine MV1036-226 is designed for tests on electrical machines with 60 Hz ratings.

The same concerns Torque Meter DC-Machines with double ended shafts, with basic codes MV1026 and Drive Machine MV 1028 as well as test machines DC MV1006, to which one of the suffixes, -225 or -226, is added as necessary.

AC Test Machines

The suffix indicates in this case frequency and supply voltage as follows:

-405 supply voltage Star 400 V, Delta 230 V, Frequency 50 Hz
-406 same supply voltages, Frequency 60 Hz

Examples:

MV1007-405: Induction Motor, slip-ring, Star 400 V, Delta 230 V, 50 Hz and 60 Hz
MV1008-236: Synchronous Machine, Star 230 V, Delta 133 V, 60 Hz

Sometimes, when there is a '5' as last digit in the suffix, e. g. MV 1007-405, the product can be used both for 50 Hz and 60 Hz (see data in the catalogue).

Load Resistor MV1100

Suffix -115 or -235 indicates only supply voltage for the cooling fan. The unit itself can be used as a load for all the voltages occurring in the electrical machine laboratories, within the admitted current limits.

Other Equipment

The same principles apply to all other items in the price list, coded with a basic number with a suffix. For other technical details, please check the catalogue.

PLEASE NOTE:

Equipment for other supply voltages can be supplied on request

Terco reserves the right to make changes in the design and modifications or improvements of the products at any time without incurring any obligations

Section 13

Loads





MV1100 Load Resistor

MV1100 Load Resistor

MV1100 Load resistor contains three ganged resistors with continuous spindle regulation. The resistors are connected to terminals for 3-ph, single-phase or DC-voltage. The current in the resistor is limited by tubular wire fuses in each phase. A cooling fan is placed at the bottom of the resistor.

MV1100-235 Cooling fan supply 230 V AC 50 - 60 Hz

MV1100-116 Cooling fan supply 110 V AC 60 Hz

General Data

3-phase 3.3 kW, continuously adjustable.

Star connection	400 / 230 V	0.8-5 A
Star connection	230 / 133 V	0.5-5 A
Delta connection	400 / 230 V	2.4-5 A
Delta connection	230 / 133 V	1.3-8.7 A
DC parallel connection	220 V	2.3-15 A
Overload capacity, brief duration, approx. 20 %.		
Dimensions	630 x 250 x 890 mm	
Weight	46 kg	

MV1101 Load Reactor

Enclosed in a strong metal cabinet. The front panel has mimic diagram, terminals, fuses and electrical data. The unit can be used on 1- and 3-phase systems. 12 step regulation.

General Data

2.5 kVAr, 50-60 Hz

V	Connection	Hz	A
230	star	50	0.2-2.2
230	delta	50	0.6-6.6
400	star	50	0.4-3.8
230	star	60	0.2-1.9
230	delta	60	0.5-5.6
400	star	60	0.3-3.3
Dimensions	510 x 220 x 320 mm		
Weight	40 kg		



MV1101 Load Reaktor

MV1102 Load Capacitor

Housed in a metal cabinet. Electrical data and symbols on the front panel with terminals and fuses. This unit can be used on 1- and 3-phase systems. 6 step regulation.

General Data

2.8 kVAr at 50 Hz, 3.3 kVAr at 60 Hz.

V	Connection	Hz	A
230	star	50	0.4-2.4
230	delta	50	1.2-7.2
400	star	50	0.7-4.2
230	III (parallel)	50	2.1-12.6
230	star	60	0.5-2.8
230	delta	60	1.4-8.6
400	star	60	0.8-5.0
230	III (parallel)	60	2.5-15
Dimensions	185 x 370 x 170 mm		
Weight	7 kg		



MV1102 Load Capacitor



MV1107 Load Reactor

The reactor is continuously variable within the range 0.5-3.0 kVAr. When the reactor is connected to a system with 230 V between lines, the setting range can be increased to 0.15-3.0 kVAr by using Y-connection.

The required reactive power is set by means of a crank. For easier setting, the load reactor has a ten-turn scale with 100 scale divisions for each turn. Each winding is fitted with a fuse.

General Data

3-phase 0.5-3.0 kVAr, 400 V Y, 230 V Y, 50-60 Hz

V	Connection	Hz	A
230	star / delta	50	0.4-7.8
400	star	50	0.7-4.5



MV2636 AC & DC Starter

This is an universal starter for both AC slip-ring induction motors like MV1007 and for DC-motors like MV1006, MV1028

Dimensions	350 x 260 x 150 mm
Weight	4 kg



MV1955 Rheostat

The rheostat is enclosed in a robust metal case. The back, bottom and top of the case are perforated to provide optimum cooling.

Two glass fuses protect the resistor against excessive current and incorrect connection. A scale having 100 divisions indicates the resistance setting.

General Data

Power	100W
Resistance	100 Ohms
Max Current	1 A
Dimension:	140 x 130 x 145 mm
Weight:	1 kg

MV1957, MV1959, MV1963 Rheostats

Each rheostat is enclosed in a robust metal case. The back, bottom and top of the case are perforated to provide optimum cooling. 2 glass fuses protect the resistor against excessive current and incorrect connection. A scale with 100 scale divisions shows the resistance setting.

A front panel of yellow painted steel with black screen painted symbols simplifies series and potentiometer connection.

Constructional features

The insulation is of high class ceramic material. The resistance wire used is of highest quality with very good linearity.

Large flat brush with a sliding contact of copper graphite with specially balanced mounting guarantees perfect contact with negligible wear on the resistance.



Cat. no.	W	Ω	I (A)	Dimension HxWxD mm	Weight
MV1957	200	5	6.3	140 x 130 x 145	1.5
MV1959	200	50	2.0		
MV1963	500	2500	0.45	215 x 195 x 230	3.5

Instruments and Measuring Devices

Measuring and Data Acquisition for PC

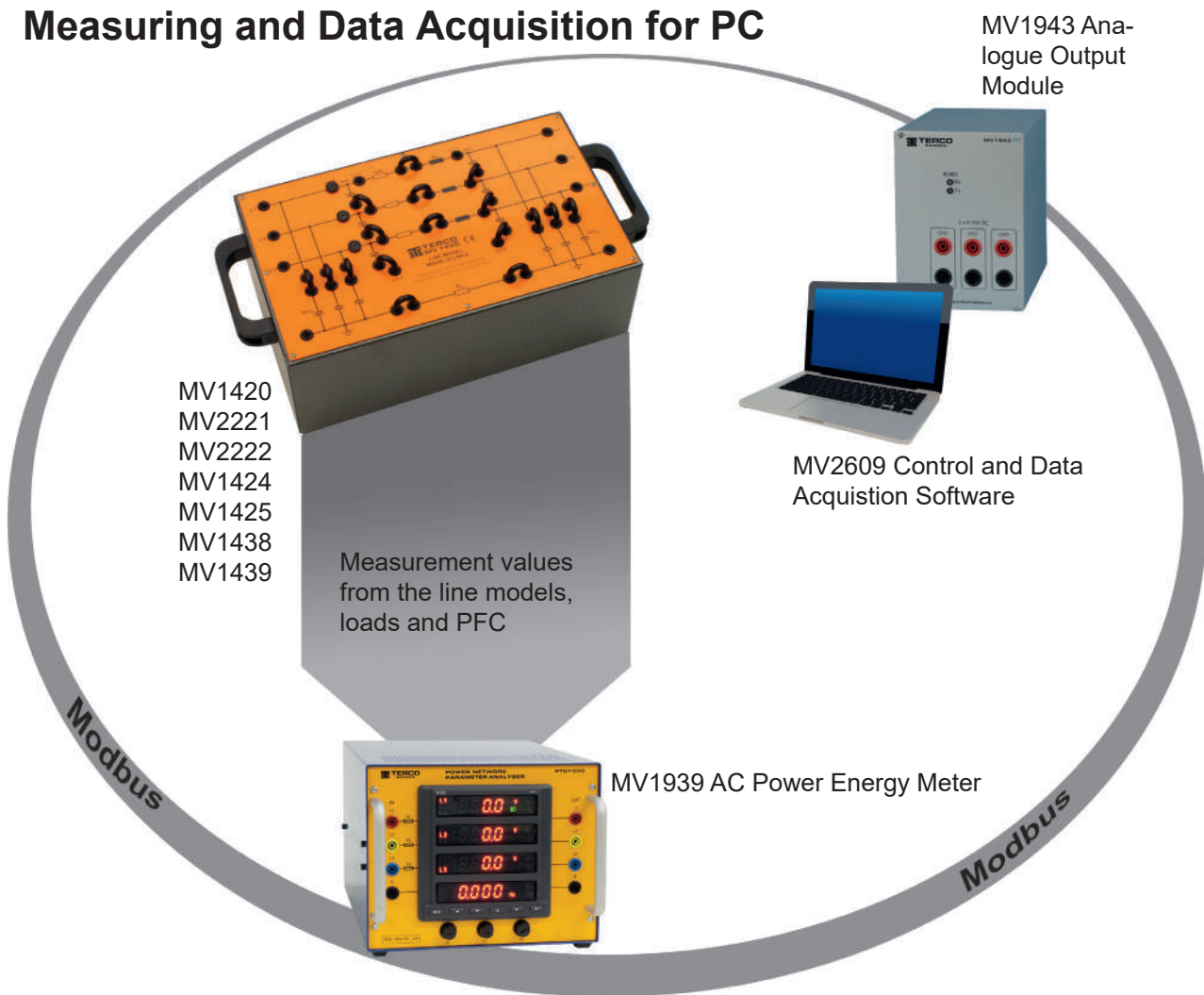

The system contains of an combination of Measuring units, Control Units, Data Interface Module and Data acquisition software, enabling the user to observe, control, record and investigate relevant electrical data. An other typical application is electrical machines laboratory.



MV1942 Measuring Module

Technical Specifications

Communication:

Interface	USB plug and play
Operating system	7/Vista/XP
Field interface	RS485
Maximum devices	32 devices
Power source	USB port



MV1943 Analogue Output Module

The MV1943 Analogue Output Module integrates the communication interface functionality of a USB to RS-485 adapter, with a 3-channel Modbus controlled 0-10V DC source in one compact unit.

Coupled with the MV2658 PWM Control unit, the MV1943 provides both communication between Terco measuring units and a PC, as well as simultaneous motor control.

The 3-channel analog output is controlled via PC using the Terco Data Acquisition Software and enables additional features such as fully automatic data acquisition.

Technical Specifications

Power supply 220-240VAC, 50/60Hz

Communication:

Interface	USB plug and play
Operating system	7/Vista/XP
Field interface	RS485
Maximum devices	32 devices
Power source	USB port

Voltage output:

Channels	3
Channel output	0-10 V
Resolution	12 bit (2.5 mV)
Isolation	1500 Vac, Field to Logic
Control system	Terco MV2609 Control and Data Acquisition Software
Dimensions	105mm x 147mm x 167mm
Weight	300g

Terco reserves the right to make changes in the design and modifications or improvements of the products at any time without incurring any obligations

MV2609 Control and Data Acquisition Software

Acquisition functions

Data is read into the PC via Modbus to USB link and presented in real-time in both tabular and graph form.

Data may be acquired using one of 4 possible acquisition modes: Single, Timed, Semi-Automatic and Full Automatic*.

The saved data can then be exported in Excel format for further investigation.

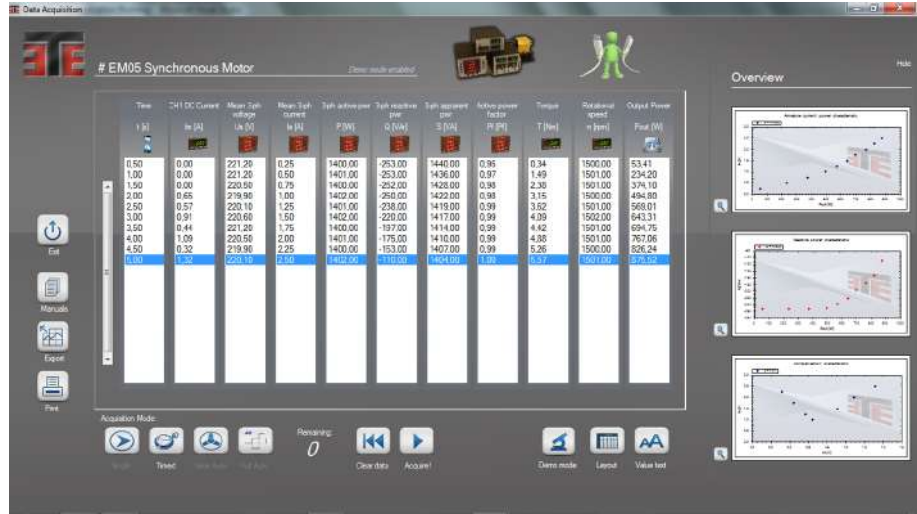

Pre-configured experiment setups are included but the experiment presentation window is fully customizable, allowing the user to select available hardware, define data columns and set up graph parameters such as data sources and titles.

The software is designed to work with Terco Modbus instruments but may be set up to communicate with many Modbus devices.



Control functions*

When used together with the MV1943 Analog Output Module and the MV2658 PWM DC Control Module, the Control and Data Acquisition Software can be used to automatically control a DC machine which can be implemented, for example, as a mechanical brake.



Software delivered on USB flashdrive.

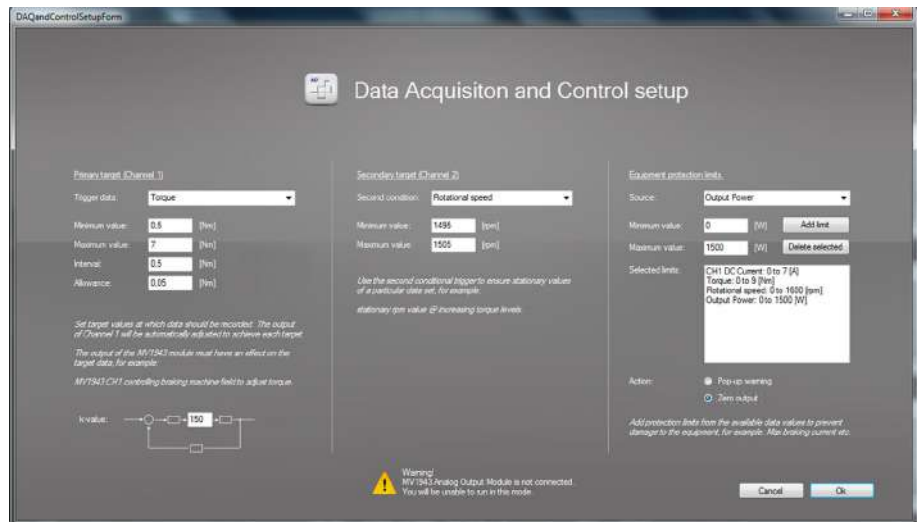

Instrument

MV1939 AC Power Energy Meter

MV1939 AC Power Energy Meter is a practical solution for the study of 1, 2 and 3-Phase AC power systems up to 500VAC/10A.



The Power Energy Meter enables the measurement and visualization of a wide range of parameters in the study of symmetrical as well as non-symmetrical networks, such as:

- phase voltages
- phase-to-phase voltages
- line currents
- mean three-phase current
- mean three-phase voltage
- mean phase-to-phase voltage
- three-phase active
- reactive and apparent powers
- mean three-phase power factors.

The visualization of parameters is distributed over several pages (default preset to display five pages) where each page simultaneously displays four parameters.

Technical Specifications

Power supply	220-240VAC, 50/60Hz
Measurement ratings:	
Voltage / Current	500VAC max / 10AAC max
Reactive / Active Power	5 kVA _r / 5 kW
Cos Phi	0-1-0

Communications:

Serial interface	RS485
Transmission protocol	Modbus RTU8N2
Baud Rate	19200kB
Dimension	255 x 205 x 335mm
Weight	10kg



MV1941 DC Measuring Unit

for study of DC circuits up to 350VDC/12ADC.

The simplified connection process means your laboratory experiments can be set up and taken down in just minutes, leaving more time to investigate and understand the characteristics and ambiguities of the circuits being investigated.

Robust components provide a good level of protection against incorrect connection, mishandling and carelessness.

Technical Specifications

Power supply	220-240VAC, 50/60Hz
Measurement ratings:	
Voltage / Current	350V DC max / 12A DC
Communications:	
Serial interface	RS485
Transmission protocol	Modbus RTU8N2
Baud Rate	19200kB
Dimension	255x205x335mm
Weight	7kg



MV1974 Voltmeter, moving coil

Voltage: 0 - +/- 300V

Safety sockets

Accuracy class: 1.0

Dimensions (HxWxD): 95 x 200 x 80 mm

Weight: 1,4 kg

MAT220350 Digital Clampmeter AC/DC current

MAT220350 is a AC/DC clamp meter in a very practical size. The instrument measures both AC and DC current and is able to, due to the size, to measure almost everywhere - also in places where it should be impossible with a normal clamp meter. The instrument is equipped with an automatic zero adjustment function. It has data hold for locking of measuring values and complies with IEC 61010-1 CAT III 300V. Is delivered in pouch incl. batteries and manual.

Technical data

Current: 0-40-300A AC/DC

Resolution: 0,01-0,1

Accuracy: DC $\pm 1\% + 2D$, AC $\pm 2\% + 5D$

Display: 3 3/4 digits Max display: 3999

Clamp size: 24mm

Battery: 2x1,5V LR44 (inkl.)

Size: 145x51x25 mm

Weight: 95 g





MAT220730 Benchtop digital oscilloscope, 2 x 70 MHz channels

The oscilloscope is particularly compact and simple to use, with a casing specially designed for laboratory use. It's equipped with a wide display offering 18 div. in full-screen mode. This allows customization of the display: choice between normal or persistent display, YT or XY format, adjustment of the colours, graticule, brightness, contrast, etc. Rotary buttons and backlit keys give access to the commands on the front panel. With its handle, oscilloscope is easy to transport and its non-slip feet make it particularly stable. High performance and multiple functions for acquisition and analysis. There are 3 acquisition levels for acquisition and analysis, in real time or equivalent time. The memory depth for acquisition is 32 kpoints or 2 MPoints to optimize your analyses. The vertical sensitivity is from 2 mV/div. to 10 V/div. with 12 ranges and the horizontal sensitivity is from 2.5 ns to 50 s/div. Advanced functions are also available: simple MATH functions (+/-/x/÷) and "real-time" FFT with simultaneous display of the traces.

The EASYSOPE software delivered with the product can be used to control and test the oscilloscope and to recover the trace and screenshot files.

- 7-inch ¼ VGA colour display
- Full menus in 5 languages + on-screen contextual help in English
- 2-channel measurement capture + Ext Trig and complex triggers
- Vertical resolution: 8 bits
- 32 automatic measurements + cursors
- USB host and device communication
- IEC 61010-1 / 300 V CAT II



PHASECOP2 Phase Cop 2 Phase Sequence Indicator

Tester for determining the direction of rotation or phase sequence in 3-phase systems.

- 3 LEDs indicate whether or not the 3-phase conductors are live
- Very large voltage and frequency range
- Simple operation
- Rugged design
- Permanently connected cables with contact-protected connector plugs, three plug-on test probes and one plug-on alligator clip

Voltage range	90-660 V
Frequency	45-1000 Hz
Dimensions	70 x 105 x 40 mm
Weight	0.3 kg



MAT220020 Analogue Multimeter

Genuinely double-insulated up to 1500 V in line with safety standards (case insulation voltage above 8 kV). SECUR'X locking prevents the test leads from being disconnected accidentally. If the leads remain connected, it is impossible to open the case (to change the battery or fuses). With protection of all ranges, the inputs support transients up to 6 kV.

37 functions and ranges: audible warning with rapid continuity, safety alarm, measurement up to 1500 V, diode test, measures 10 A DC with low voltage drop. Flexible, moulded, splash-proof case, with 80 mm linear scale. AA alkaline batteries.

Standards

class 2 IEC 61010-1, cat. III Pol-2

Maximum Resistance Measurement 20kΩ

Functions Measured:

DC+AC Current, DC+AC Voltage, Resistance

True RMS No

Maximum Frequency 1000Hz

Maximum Operating Temperature +50°C

Best AC Current Accuracy ±2.5 %

Width 98mm

Length 40mm

Dimensions 40x98x150mm

Best DC Voltage Accuracy ±2 %

Best AC Voltage Accuracy ±2.5 %

Height 150mm

Weight 420g

Safety Category Level CAT III

Best DC Current Accuracy ±2 %

Safety Category Voltage 600V

Battery Type AA

Best Resistance Measurement Accuracy ±10 %



MAT220575 Handscope 20MHz incl. software

20MHz bandwidth, two galvanically insulated channels and two independent 8000 digit multimeters with power measurement.

TFT color screen with 320 x 240 pixels resolution and with LED backlight for clear and accurate reading of measurement data.

Up to 2MB of data can be stored in memory as a waveform or text file as well as screenshots such as images, bmp. Configuration settings can also be saved.

With insulated USB that has SCPI protocol, it's easy to use remote control. With the rechargeable batteries available up to 8 hours of use.

Delivered with:

- 2 probes 1/10 500 MHz
- 2 banana adapters
- cable set, red / black with crocodile clips and measuring tips
- charger 230 V AC and rechargeable batteries
- bag
- USB cable HX0056-Z and 1 CD with SX-Metro software
- USB drivers

Specifications

Channels	2
Inputs/ Bandwidth	2 X 600V Isolated channels / 20MHz
Max. sampling rate	2GS/s in ETS – 50MS/s in Single Shot Mode on each channel (9 bits)
Sensitivity	≤ 1.2 divisions p-p up to 20 MHz
Communication	USB
Memory Depth	2500 points/channel
Warranty	3 year
Safety	IEC/EN 61010-1 (1000V CAT II; 600V CAT III), IEC 1326-1



MAT220118 Digital multimeter

TRMS multimeter with a bandwidth up to 1 kHz. The instrument has built-in voltage indication, so-called "phase function".

Measurement of current up to 10 A as well as capacitance and temperature with thermocouple type K. Further available is Min / Max function and relativity measurement.

The instrument is rated for category IV 600V and has a large, backlit 6000-digit display with bargraph function. Automatic voltage detection and auto shutdown. Built-in shock protection and high enclosure class



MV1922/1923 Ammeter

A sturdy amperèmeter with high accuracy and reliability. Extremely safe with safety sockets and dual insulation. Moulded, water-resistant casing.

Range	AC 10mA - 10A (7 steps) DC 100µA - 10A (7 steps)
Accuracy	1,5% (DC), 2% (AC)
Operating frequency	45 - 400Hz
Fuse	1A and 10

Dimensions:	170 x 110 x 60 mm
Weight:	0.4 kg



MV1926 Voltmeter

A sturdy voltmeter with high accuracy and reliability. Extremely safe with safety sockets and dual insulation. Moulded, water-resistant casing.

Range	AC 3V - 1000V (6 steps) DC 100mV - 1000V (8 steps)
Accuracy	1,5% (DC), 2% (AC)
Operating frequency	20 - 400Hz
Fuse	Electronic Protection

Dimensions:	170 x 110 x 60 mm
Weight:	0.4 kg

Terco reserves the right to make changes in the design and modifications or improvements of the products at any time without incurring any obligations



Note : This wattmeter has a lamp and a buzzer warning for both overvoltage and overcurrent.

MV1937 Wattmeter

MV 1937 is an Electronic Wattmeter with active power transducer. The instrument is panel-type 96 x 96 mm and mounted in durable varnished sheet metal enclosures having plastic feet. The instrument has a 90° scale and manages temperatures between -20° and +50°C. It complies with IEC recommendations.

Technical Data

Voltage ranges: 50 – 250 – 500 V AC / DC

Current ranges: 5 – 10 A, AC / DC

The current ranges can be changed with a switch when measuring.

Voltage inputs: max 600 V

Current inputs: max 20 A

The current inputs and voltage inputs are insulated from each other : 1.5 kV

Accuracy: 2.5 %

Frequency range: DC – 20 kHz

Input impedance: > 100 kohm (voltage input)

< 3 mohm (current input)

Power supply: 220 – 240 V 50 – 60 Hz

Dimensions: 220 x 117 x 125 mm

Weight: 2 kg

MV1929 Power Factor Meter

Three-phase instrument, symmetric load.

Measuring range cap. 0.5 ... 1 ... 0.5 ind.

Current range 0-5 A

Voltage range 220 V ± 20 % 3-phase

Frequency range 40-65 Hz

Accuracy class 1.5

Dimensions: 220 x 117 x 125 mm

Weight: 2 kg



MV1976 Power Factor Meter

Three-phase instrument, symmetric load.

Measuring range cap. 0.5 ... 1 ... 0.5 ind.

Current range 0-5 A

Voltage range 380 V ± 20 % 3-phase

Frequency range 40-65 Hz

Accuracy class 1.5

Dimensions: 220 x 117 x 125 mm

Weight: 2 kg



MV1971 Differential Probe

Voltage up to 1200 V

Frequency range: DC - 1 MHz

Impedance in: approx. 1 Mohm

Impedance out: approx. 500 ohm

Dimensions (HxWxD): 40 x 120 x 65 mm

Weight: 0.3 kg



Terco Electrical Machines Laboratory in Umeå University in northern Sweden



Accessories



MV1400 Push Button Panel

MV1400 is a suitable control device

It consists of :

- a signal lamp
- an OFF-button with one break and one make contact
- an ON-button with one break and one make contact.

The buttons are of non-locking type with instantaneous action so that contact operations are felt on depression of a button.

Dimensions (HxWxD): 75 x 175 x 130 mm

Weight: 1 kg



MV1417 Terminal Board with Short-Circuit Buttons

Combined terminal and protection board for instruments. Current coils of ammeters and wattmeters connected to the board through a normally short-circuited contact which is opened during measurement. Opening of the contacts for phase R, S, T is done with a robust push-button for each phase. Reading of the instrument can be done only when the button is pressed, which is of great advantage in the event of wrongly terminated instruments.

Dimensions 245 x 195 x 50 mm

Weight 1.5 kg

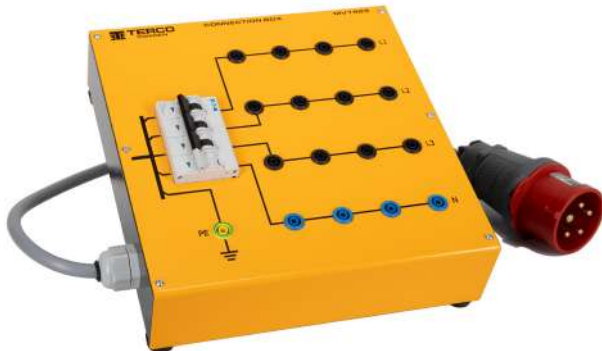

MV1429 Terminal Board

The box has outlets (three phases, zero and earth) for laboratory leads with 4 mm diameter plug ins. These outlets are connected to a 5 x 2.5 mm² cable with a 3-phase CEE plug rated 16A. The connection box is equipped with miniature circuit breakers for 16 A.

Dimensions: 250 x 240 x 75 mm

Weight: 2.0 kg



MV1500 Load Switch

Three-pole, 16 A, 250 V- DC/440 V-AC,

Dimensions 95 x 200 x 80 mm

Weight 1 kg

MV1502 Reversing Switch

Suitable for 3-phase machine, 16 A, 500 V

Dimensions 95 x 200 x 80 mm

Weight 1 kg

MV1503 Star / Delta Switch

Suitable for 3-phase machine, 16 A, 500 V

Dimensions 95 x 200 x 80 mm

Weight 1 kg



MV1931 Current Transformer

Primary: 20-15-5 A/Sec. 1 A

Safety sockets

Accuracy class:1.0

Dimensions (HxWxD): 95 x 200 x 80 mm

Weight: 6 kg

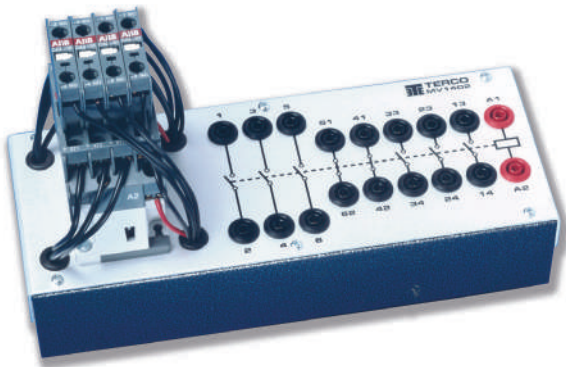

MV1402 Contactor

The contactor is one of the most common components in automation. It issued, for instance, in remote control and automatic control systems.

General data

- 3 main contacts with thermal current rating 25 A at resistive load
- 5 auxiliary contacts (3 make and 2 break) with thermal current rating 10 A
- Operating coil, 50 Hz or 60 Hz, 230 V

Dimensions (HxWxD) 150 x 245 x 130 mm

Weight: 1.3 kg



ELE102002 Storage Rack 1 row

Storage rack for safe storage of the lab cards. It is constructed of hard plastic and very durable.

Dimension: 355 x 180 x 180 mm

Weight: 1.4 kg



ELE102004 IK Storage Rack 2 row

A system storage rack for IK 1 to IK 6 and HK 1. The storage rack will protect the Lab Card against electrical and mechanical damage.

Dimension: 340 x 180 x 355 mm

Weight: 2 kg

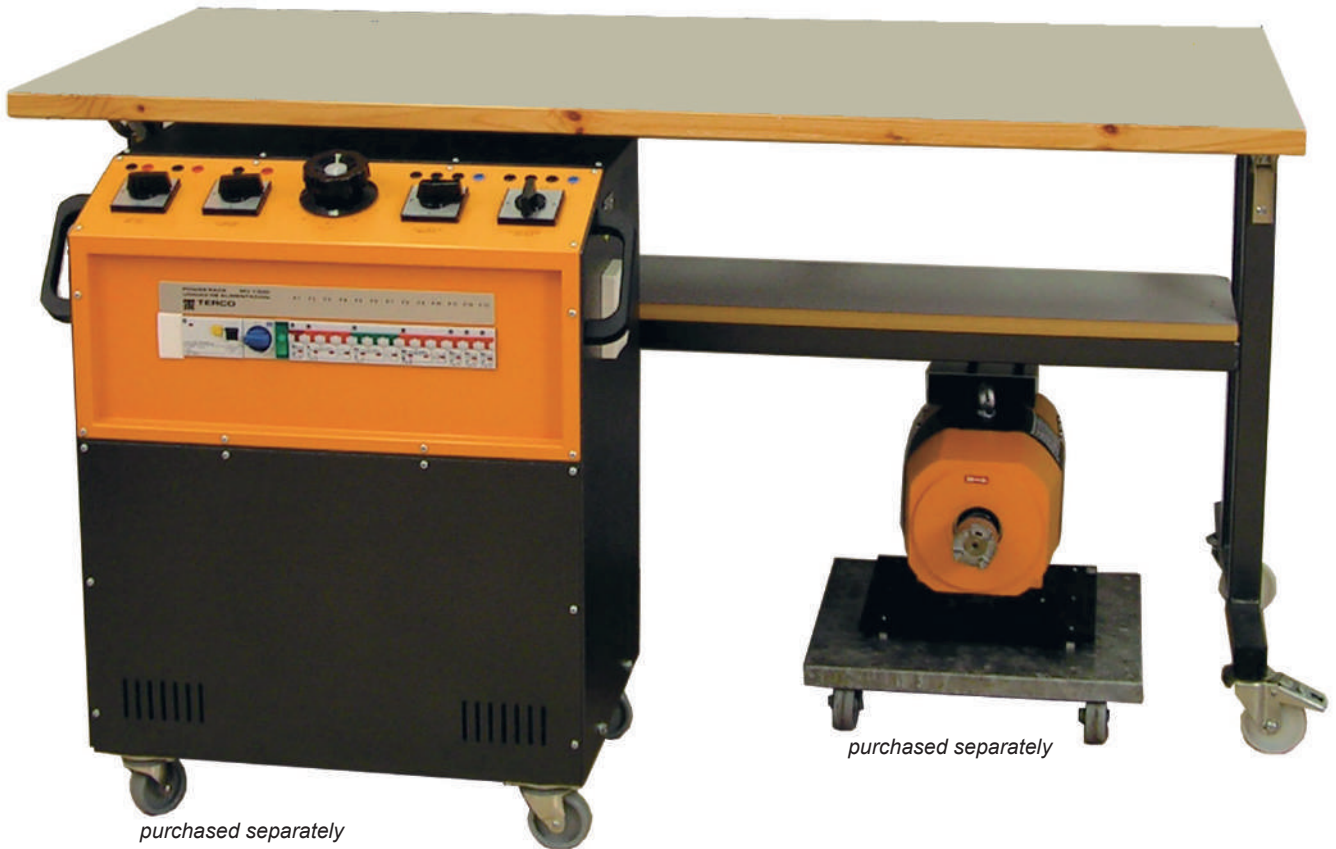

MV1003 Mobile Test Bench

For mobile use, the torque meter or brake system and test machines with machine bed are placed on a mobile bench having one folding leaf, one fixed shelf and four wheels, of which 2 can be locked.

Dimensions of the folding leaf 1490 x 400 x 30 mm
Dimensions 1500 x 600 x 840 mm
Weight 55 kg

Terco reserves the right to make changes in the design and modifications or improvements of the products at any time without incurring any obligations

Laboratory Flexes with Safety Plugs, Fixed Sleeve



MV1830-HF Flex Set Area 1.5 mm²

Set of 100 leads in 5 different colours, red, yellow, blue, black, yellow/green, and 4 different lengths, 25, 50, 100 and 200 cm, 5 of each.

	25 cm	50 cm	100 cm	200 cm
Red	5	5	5	5
Yellow	5	5	5	5
Blue	5	5	5	5
Black	5	5	5	5
Yellow/green	5	5	5	5





LEY500590 Safety Jumpers

Short circuiting 4 mm black jumpers used for connecting motors etc

Dimension: 38 x 26 x 8 mm
Weight: 0.05 kg.



MV1904 Flex Stand

For suspension of laboratory flexes. The stand has 12 slots between parallel tubes with space for 10-15 laboratory flexes in each slot. Flexes of length 200 cm are suspended in a separate position above the stand. This rigid stand has a heavy steel plate pedestal.

Height: 1170 mm
Weight: 9 kg



MT0415 Compressor

Suitable compressor for Mecha-Kit. This is a piston type oil-lubricated compressor driven by a single phase electric motor and of fully automatic design. The compressor works silently and without vibrations.

The compressor is equipped with:

- Overload protection
- Pressure switch with unloader
- Safety valve
- Manometer
- Drain cock
- Filter regulator with 5µm filter

General Data:

Power supply: 220-240V, 50-60Hz 1-ph
Power consumption: 250W
Capacity: 26 l/min at 8 bar
Max. working pressure: 8 bar
Tank size: 15 l

Dimension: 380 x 380 x height 470 mm
Weight: 22 kg



Foldable Device Panel

Raised for experimentation...



Folded for theory ...



In summary, design with FDP2100 Foldable Device Panel means:

- High security
- RCCD switch that breaks at 10mA.
- It is quick
- Better utilization.

For further information contact TERCO at export@terco.se

What is a FDP / VIP Table?

The VIP panel consists of a door made of the same material as the table, and a chassis made of painted sheet metal filled with power supplies, instruments and the equipment required for teaching.

When the tables are to be used for laboratory work, the VIP panel is lifted up by a motor. In most cases, the operation is operated up and down by the teacher, but there are also options where the function is operated with a switch directly under the table.



What equipment should be in the electrical panel?

The equipment that should be in the electrical panel depends on the laboratory activities that will take place in the room. Safe mains voltage is always needed. The "cube" is obvious for all teachers who teach physics or electrical engineering.

The teachers are the ones who know best what is most commonly used. If there are changes in the activities, there may be requirements for other voltage sources or instruments. We offer different sizes of chassis and it is better to be safe with a larger chassis to be able to supplement with other or more modules in the future.

The images below show examples of the VIP panel folded up.



In summary, furnishing with VIP tables means:

- A high level of safety is maintained by the teacher controlling which students have access to live equipment.
- Ground fault circuit interrupter that trips at 10mA.
- It is quick to get started and finish the work shift.
- Space is optimized as all equipment is integrated into the student desk, enabling multi-use classrooms.
- The risk of damage and theft of expensive equipment is minimized as they are built into the VIP table.

Electrical Safety

Terco has been working with electrical safety and technical educational materials in schools for more than 50 years. We are therefore well acquainted with how children and young people use curiosity and playfulness as an important part of learning. Therefore, extra requirements must be placed on electrical installations in a physics and technology lab at school.

Plan the laboratory space

In addition to a safe electrical environment, it is also very important that the interior design is carried out so that the laboratory work can be carried out efficiently and with good quality. Given the rapid changes in educational orientations, the lab must also be designed flexibly.

The design and purpose of the room determines which size table is appropriate. At a table that is 1800mm long, two students can perform laboratory work, while in theory it can accommodate 3 students.

Example of a combination classroom

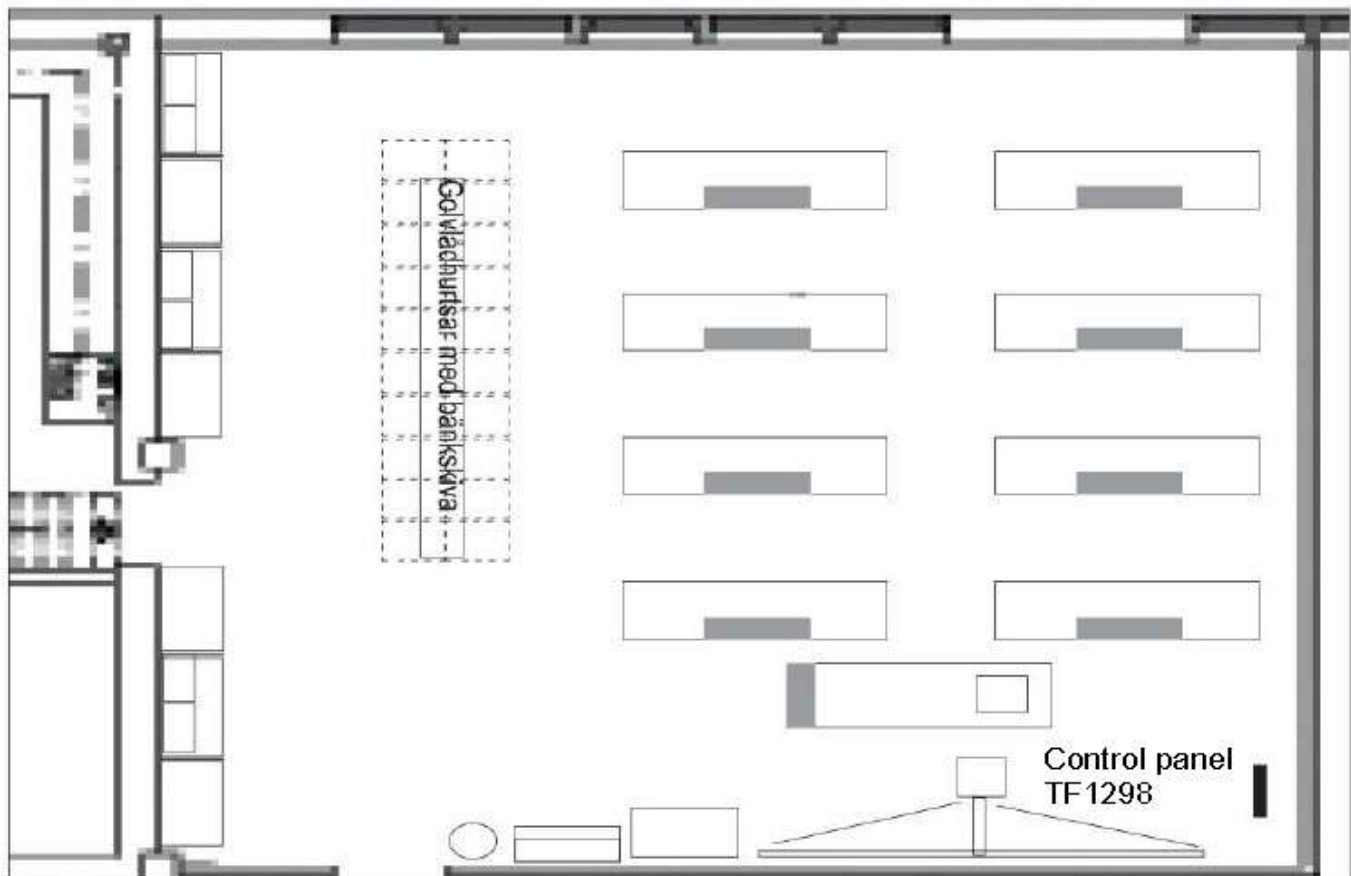

The drawing shows an example of a combination room where both physics and chemistry labs can be carried out. The room can also be used as a theory room. The most suitable distance between the tables is at least 800 mm.

Material selection and color options for student desks

Our table tops and stands are manufactured to high quality to last in tough school climates for decades. In our standard range of tabletop laminates, we offer beech, birch, oak, white and ESD-classified light gray laminate.

The tables we manufacture most often are made of beech with matching edge strips and a gray powder-coated frame. It is also possible to match laminate with a different edge strip. For example, a white table top with a black

Any table dimensions from 1200 mm - 3000 mm in 100mm increments can be ordered. edge strip.

Laminate for tabletop

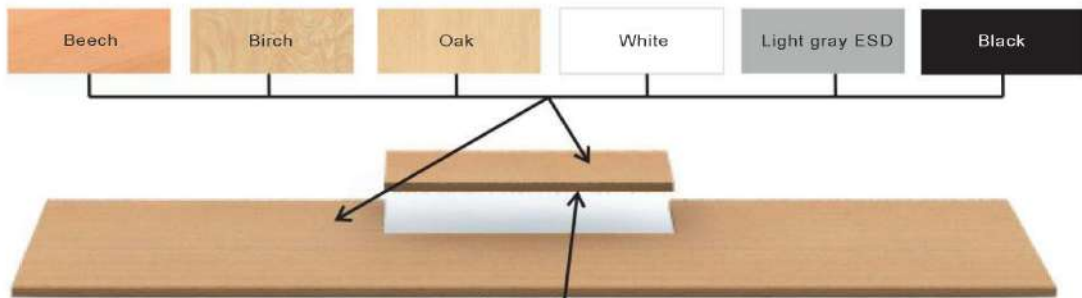

Edge strips

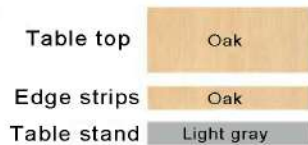
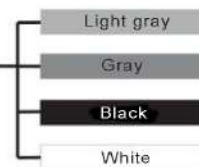
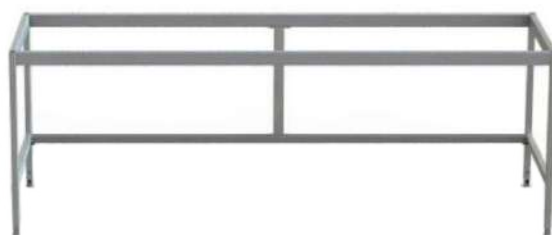

Material selection and color options for teacher desks

The difference between a VIP student and teacher table is the placement of the VIP panel. On the teacher table, the VIP panel is placed at the left end rather than centered like on the student table. This is so that the teacher can illustrate laboratory exercises for the students as seen from sitting in the classroom from their own VIP student table.

Laminate for tabletop

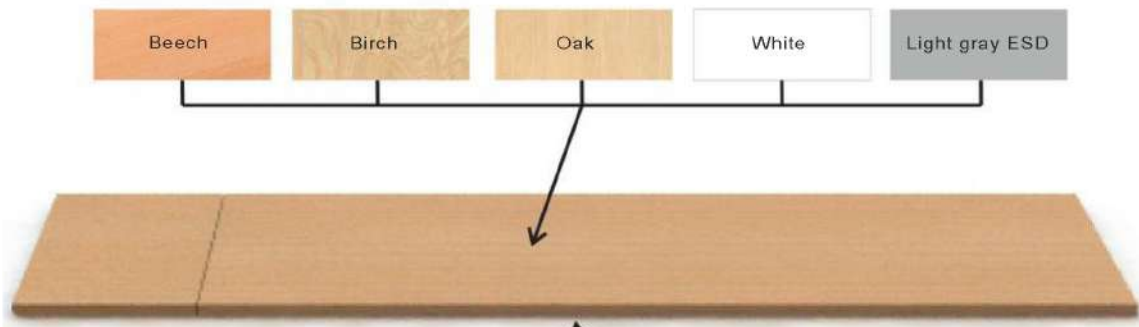

Edge strips



Front- and side protection

Front- and end protection are available as options and are made from the same laminate as the table.

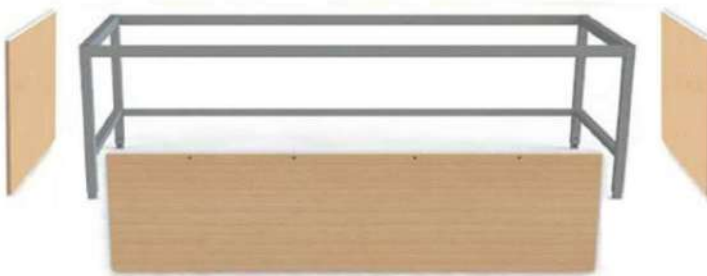

Combination table with sink and faucet

Example of equipment in VIP-panel

The images below show examples of what our various chassis can be equipped with.

VIP 700mm which holds 14 modules.
 VIP 1000mm which holds 20 modules.
 VIP 1300mm which holds 26 modules.

The choice of chassis depends on what kind of equipment the VIP panel will contain and how many students will sit at each student desk.

We help you develop suitable solutions for your purpose. You will find all the equipment further down in the brochure as well as how many modules each instrument takes up, so you can calculate the VIP panel that is most suitable.



VIP chassis 700mm that holds 14 modules. In the example below a 1-phase security panel, a voltage module (so-called cube) 0-30V AC/DC 5A and 2 digital multimeters with built-in battery eliminators



VIP-Chassis 1000mm that holds 20 modules. In the example below, a 1-phase safety panel, a voltage module (so-called cube) 0-30V AC/DC 5A, 2 digital multimeters with built-in battery eliminators, 3 grounded, tamper-proof 230V, amplifier for function generator and function generator with sine, square and sawtooth waves.



VIP-Chassis 1300mm that holds 26 modules. In the example below, a 1-phase safety panel, a voltage module (so-called cube) 0-30V AC/DC 5A, 2 digital multimeters with built-in battery eliminators, an oscilloscope, voltage module +/-5V and +/-12V 1A stabilized and 3 grounded, tamper-proof 230V sockets.



VIP Panel and table stand alone

Our VIP panels can also be ordered for table mounting or hanging if you already have existing tables in the classroom. See below for an example of how our VIP panel can look when mounted on a table.



Table montage



VIP panel in table for surface optimization.

Equipment and accessories.

If you are unsure about what equipment you should equip your VIP tables with, you are welcome to contact us for a free consultation.

What is important to keep in mind is that the Safety panel 1-phase TF8020-10 must be included as it is this unit that supplies power and voltages other equipment that is selected for.

Ref.nr	Safety panel 1-phase	ME
TF8020-10	Safety panel 1-phase. Main switch, fuse, earth fault switch 10mA, 3 single, puncture-proof grounded 230V sockets	4 ME
TF8020-FIN	Safety panel 1-phase. Main switch, fuse, 3 simple, touch-proof grounded 230V sockets. Momentary on/off switch with contactor. Must be used unless control panel with holding contactor is used (see TF1298)	4 ME
	Säkerhetspanel 3-fas	
TF8020-30	Safety panel 3-phase. Main switch, fuse, 2 tamper-proof grounded 230V sockets.	6 ME



TF8020-10



TF8020-FIN



TF8020-30

Security panels and outlets continued

Ref. nr	Outlet and emergency stop	ME
TF8037	3-phase through 4mm banana connector, signal lamp, main switch.	2 ME
TF8046	Emergency stop including hold contactor.	1 ME
TF8032	3 grounded, tamper-proof 230V sockets.	2 ME
TF8032-RJ45	2 data sockets	2 ME
TF8032-RJ45-230	2 grounded tamper-proof 230V sockets and 1 x RJ45 sockets.	2 ME
TF-ESD	Outlet for ESD	



TF8037



TF8032



TF8046

Power supply

Ref.nr	Power supply	ME
TF8021	Power supply 0-250V, 1A	4 ME
TF8022	Voltage module (so-called cube) 0-30V AC/DC 5A	5 ME
TF8023	Power supply 0-30V DC, 3A stabilized	3 ME
TF8025	Isolation transformer 230V 1,5A/115V 3A	3 ME
TF8026	Voltage module +/-5V and +/-12V 1A stabilized	2 ME
TF8027	Power amplifier DC-approx. to 50kHz 15W	2 ME
TF8028	Function generator Sine and square wave TTL	2 ME
TF8030	Voltage module 6,3V AC 7A	1 ME
TF8036-55	Voltage module 5V DC 5A	1 ME
TF8040	Battery module 1,5; 4,5; 9V stabilized	3 ME



TF8022



TF8021



TF8026



TF8026

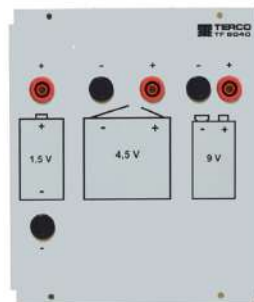

TF8040



TF8030



TF8036



TF8024 / -INB

Ref.nr	Description	ME
TF8024-INB	Mounting plate for Weller soldering station WS81	3 ME
TF8024	Weller soldering station WS81 with power 80W, soldering temperatur 50-450 C	3 ME

Instrument and accessories.



TF8033-5 Is also available as a single



TF8027



TF8028

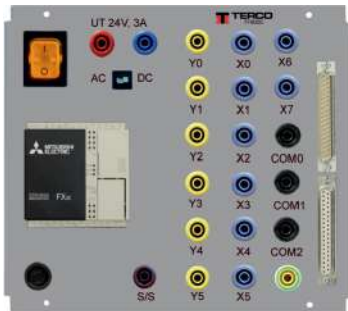

TF8050-FX3s PLC-module Mitsubishi Melsec-FX3s 6 input, 8 output Current max for application:24V, 3A



TF8031 Oscilloskop 2x100 MHz 25 G/s (GDS-1102a-U) monterad i inbyggnadsplåt.

Ref. nr	Instrument	ME
TF8027	Amplifier for function generator DC approximately to 50 kHz, 15W	2 ME
TF8028	Function generator with sine, square and sawtooth waves.	2 ME
TF8031	Mounting plate including oscilloscope	8 ME
TF8031-INB	Mounting plate for oscilloscope	8 ME
TF8033-3	1 pcs Digital multimeter CA5233 with built-in battery adapter and separate fuse	3 ME
TF8033-5	2 pcs Digital multimeter CA5233 with built-in battery adapter and separate fuses	5 ME
TF8050-FX3s	PLC module Mitsubishi Melsec FX3s, 6 inputs, 8 outputs. Max current for application: 24V, 3A	4 ME
TF8015	Blind plate 50 mm	1 ME
TF8016	Blind plate 100 mm	2 ME



Example of the VIP 1000mm chassis with:

- TF8020-10
- TF8022
- TF8033-5
- TF8027
- TF8028
- TF8032

Custom-made tables.



Flexible and modular Lab/workbench

We can offer robust workbenches developed for professional environments where function, durability and flexibility are crucial. The stable steel construction in combination with a durable work surface makes the table ideal for workshops, laboratories, educational environments and technical workplaces.

The practical superstructure with perforated tool board and adjustable shelves provides smart and easily accessible storage of tools and equipment. Integrated power outlets make it easy to connect machines, perform labs and use other electronics directly at the workstation.

In short: a stable, flexible and customized workbench that creates an efficient and organized working environment.

Scan the QR code to be able to see more!

1. Open up your mobile camera
2. Hold your camera over QR-code
3. You will now get the options to open the QR-code



VIP-panel control in classrooms

Control unit for VIP

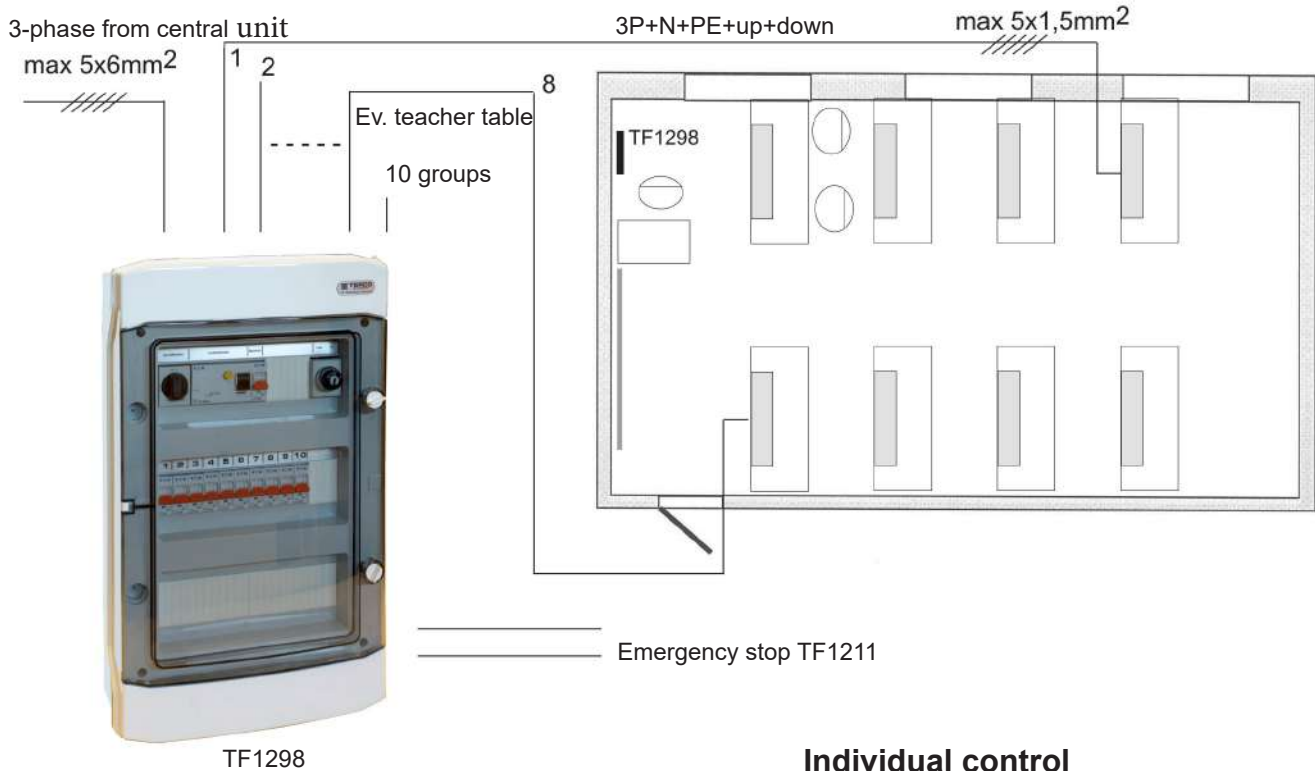

Control unit 1-phase 230V simultaneous opening of VIP panels

- Input 3x400V 3-phase
- 1 pcs main switch
 - 1 pcs key switch up/down
 - 10 pcs circuit breakers
 - 1 pcs circuit breakers for lift motor
 - 1 pcs 3-phase earth leakage circuit breaker with tripping current of 30mA

All VIP panels open and close simultaneously

Dimensions: wxhxd 320x540x150 mm

Safety equipment



- TF1211 Enclosed emergency stop incl. sign
TF1211-N Enclosed emergency stop incl. key and sign



TF8046

Individual control

TF8010 Up/down control unit for placement under the table for non-teacher-controlled operation.



Safety system with isolation transformer

Nowadays, it often happens that students work independently. Student panels that are then available to the student can be used intentionally or unintentionally incorrectly, which in turn can cause an accident. The distribution board is therefore equipped with extra protection in the form of isolated and step-down voltage in relation to ground and a zero-current circuit breaker with a maximum tripping current of 4 mA. The voltage to the electrical panels is as usual 230V, but the voltage to ground is only 130V.

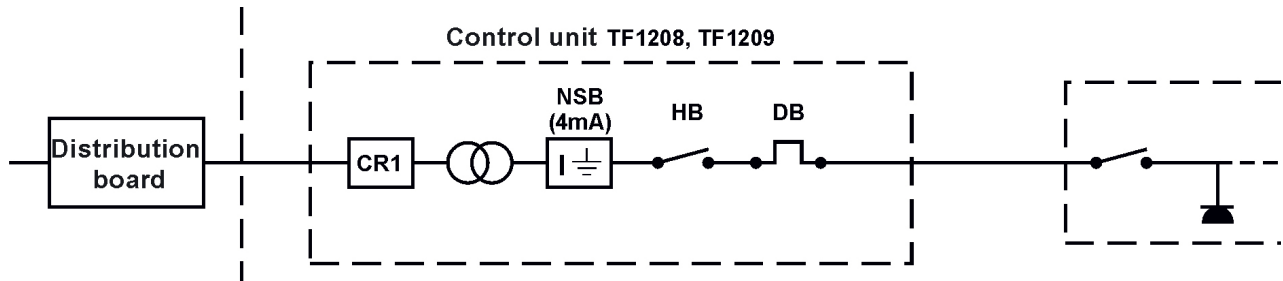

TF1209 Distribution board

The board is made of powder-coated sheet metal and is designed for wall mounting. It contains:

- Transformer for connection to primary Y-400/230V. secondary Y-230/130V Power 3.5 kVA intermittent. Also available for 5.5 kVA (TF1209-5)
- 10 pcs 2-pole MCB's, 6A, for power supply to the student seats
- 1 pcs 3-pole MCB 10A for supplying the CEE socket in the panel, and 1 MCB 2A for the control circuit.
- Protective relay Equipment that breaks when the current exceeds 4mA in the protective conductor.
- Contactor with lockable key switch, main switch and signal lamp.
- 1 pcs 2-way, tamper-proof, grounded 1-phase.
- 1 pcs 3-phase socket

Weight: 52kg

Dimensions: WxHxD 486x600x150mm

TF1209-5 Distribution board as above but out-power 5,5 kVA intermittent.

TF1209-F Additional unit to TF1209 above

Maxnumber of circuit breakers: 24.

Height 170mm

MCB's to TF1209-F must be ordered separately as below:

G1561 2-phase MCB 6A

G1562 2-phase MCB 10A

G1564 3-phase MCB 10A

TF1209-F incl. fuses must be factory-fitted by TERCO



TF1208 Distribution board

for installation in lecterns or teacher chairs.

Weight: 50kg

Dimensions: Front plate 260x480mm

Sheet metal enclosure 248x458mm,
depth 450mm

Otherwise similar content as TF1209

TF1211 Enclosed emergency stop incl. sign

TF1211-N Enclosed emergency stop incl. key and sign



Electrical panels for connection to TF1208 and TF1209 or directly to 230V

Table mounting and wall mounting

TF1210 Student panel for table mounting

TF1221 Student panel for wall mounting

The enclosure is made of heavy-duty powder-coated steel sheet and contains 2 2-way, grounded, touch-protected sockets.

Weight: wxhxd = 250x80x105 mm

Weight: 1,2 kg



Hanging socket

Terco's hanging sockets are available with or without covers, earth leakage circuit breakers and balancing blocks.

	Number of Outlets	Chain 1,5 m and spiral cable 2,2 m	Balance block wire fully extendable to 1,5 m and spiral cable 2,2 m	Lock	RCCB 1-phase 10 mA
TF1210-H	6	Yes	No	No	Nej
TF1210-HS	6	Yes	No	Yes	Nej
TF1210-HB	6	No	Yes	No	Nej
TF1210-HBS	6	No	Yes	Yes	Nej
TF1210-HJ	3	Yes	No	No	Yes
TF1210-HJS	3	Yes	No	Yes	Yes
TF1210-HJB	3	No	Yes	No	Yes
TF1210-HJBS	3	No	Yes	Yes	Yes



TF1210-HB



TF1210-HS

Product number Index

Product no	Description	page
AUT300080	Elevator Model Elevator	175
AUT300200	AU5900 Mecha-Kit Modular System	176
AUT300303	I/O-Module with DC Power Supply (Au5591)	
AUT302000	PLC Module for Base Unit 2000	146,169 173,178
AUT302001	Simulation Module	146,169 174,179
AUT302002	Traffic Lights Module	169,179
AUT302003	Cylinder Module	170
AUT302004	Terminal Block Module	170,179
AUT302005	Ball Selection Module	170
AUT302008	Socket Adapter	146,173
AUT302010	PLC mounting profile	175
AUT302011	Control Module	145
AUT302012	Contactormodule	145
AUT302102	Liquid Tank Model	156
AUT302103	Regulator Module	156
AUT302201	PID Interface PF1	155
AUT302202	PF2 Temperature Regulation Module	155
AUT302203	PF3 Speed Regulation Module	155
AUT302204	PF4 Signal Converter PF4	156
AUT302210	Sensor Set	157
AUT302500	Servo Base Plate with Linear Unit	159
AUT302502	DC Servo Motor without Gears	159
AUT302504	Flywheel	159
AUT302506	Generator Brake	159
AUT302508	SR1 Servo Regulator	160
AUT302510	SR2 Speed Regulation Module	160
AUT302512	DC Servo Motor with Gears	161
AUT302514	Process Value Module	161
AUT302516	SR3 Positioning Module	161
AUT302518	Stepper Motor	162
AUT302520	Stepper Motor Module SM1	162
AUT302522	AC Servo Motor	163
AUT302524	AC Servo Amplifier	163
AUT309905-M	Automatic Sectional Door Model	172
AUT309906	M2 Socket Module	173
AUT309907	ME1 Console	173
AUT309908	D-Sub / Sim Module	174
AUT310710	IQ Works Programming Software for PC	171
AUT310710	IQ Works Programming Software for PC	174
AUT310710	IQ Works Programming Software for PC	174
AUT310710	IQ Works Programming Software for PC	179
AUT310712	Programming Software GX Works2 Class-Set	146
BOK102212	Three-Phase AC, Laboratory Exercises	137
BOK103615	Experiments Book Motor Control	147
BOK110120	Lift Model, Laboratory Exercises	175
BOK112010	Basic Electronics Laboratory Exercises	124
BOK112030	Basic Digital Electronics, Laboratory Exercises	128

Product number Index

Product no	Description	page
BOK112050	Basic Power Electronics, Laboratory Exercises	133
BOK300200	Laboratory Exercise Book	180
BOK300201	MECHA-Kit, Text book	180
BOK300202	MECHA-Kit, Laboratory Exercises	
BOK302205	Control Technology Basic Laboratories	157
BOK302500	Theory Book Servo Techniques	164
BOK302505	Servo Control, Laboratory Exercise Book	164
BOK312002	PLC Programming, Laboratory Exercises	171
BOK320030	Introduction to PLC	171,175
EB3000	Energy and Process Control Trainer	165
ELE02002	Storage Rack 1 row	219
ELE102000	Base Unit 2000	125,127 130,138 144,154 158,168 178
ELE102001	HK 1 Help Function Card	130
ELE102002	Storage Rack 1 row	219
ELE102004	Storage Rack 2 row	219
ELE102010	Lab Card 1 Resistor	125
ELE102020	Lab Card 2 Capacitors	125
ELE102030	Lab Card 3 Diodes	125
ELE102040	Lab Card 4 Voltage Regulator	126
ELE102050	Lab Card 5 Transistors	126
ELE102060	Lab Card 6 House Alarm	128
ELE102065	Component Set DG1	128
ELE102219	IK Terminal Board	133
ELE102220	Motor Model IK7	133
ELE102221	Lab Card IK1 Power Regulator	130
ELE102222	Lab Card IK2 Transistors	131
ELE102223	Lab Card IK3 Operational Amplifier	131
ELE102224	Lab Card IK4 Static Converter	131
ELE102225	Lab Card IK5 AD/DA Converter	131
ELE102226	IK Component Kit	132
ELE102227	IK DC-Motor	132
ELE102228	Lab Card IK6 Frequency Converter, AC	132
ELE102229	IK AC-Motor	132
ELE102230	3-Phase Simulator	138
ELE102231	3-Phase Load Unit Low Voltage	138
ELE102232	3-Phase Terminal	139,144
ELE102233	3-Phase Power Load Unit	139
ELE102234	3-Phase Transformer	139
ELE102236	3-Phase Motor/Generator Module	139
ELE102237	3-Phase Box for Condensators	140
ELE102238	Current Transformer / Earth Leakage Circuit Breaker	140
ELE102239	Heating Centre	140
ELE309902	Table with wheel for Energy Bench	165
ELK102240	3-Phase Asynchronous motor with Base Plate	140,142

Product no	Description	page
ELK102242	Magnetic Powder Brake	143
ELK102244	Tachometer - RPM-Meter	143
ELK102246	Frequency Converter AC-Drive Module	143
ELK102248	DC-Drive Module	144
ELK102250	DC-Motor	143
ELK102252	Rotary Index Table	145
FOR102000	Base Unit	182
FOR102002	ES2 Parallel connection	182
FOR102004	ES4 Inductive Sensor	183
FOR102005	ES5 Hall Sensor	183
FOR102006	ES6 Relay	183
FOR102007	ES7 Electronic Power Control PWM	183
FOR102008	ES8 Terminal Board	183
FOR102009	ES9 Additional Power Supply	184
FOR102010	ES10 Demister	184
FOR102011	ES11 Component Kit	184
FOR102035	ES35 CAN-BUS ECU Module	187
FOR102052	Fault Simulator Box, CAN-BUS (ES35)	187
FOR102059	Instrument panel with expansion site	185
FOR102060	Car Model with expansion site	186
FOR102061	Parking Sensor	186
FOR102062	Gear Indicator	186
FOR102063	Touch Sensor	186
FOR102064	Rain Sensor	187
FOR102101	ES1 Series connection	182
HV1946	Coupling Capacitor	100
HV9104	Control Desk	94
HV9105	Test Transformer 100kV	96
HV9105-CON	Cascade Connection Set	105
HV9106	High Voltage Connection	99
HV9106-3	High Voltage Connection	99
HV9107	Discharge Rod	99
HV9108	Connecting Rod	99
HV9109	Connecting Cup	99
HV9110	Floor Pedestal	99
HV9111	HV Rectifier	97
HV9112	Smoothing Capacitor/Impulse Capacitor	97
HV9113	Measuring Resistor	98
HV9114	Earthing Switch	99
HV9119	Spacer Tube	99
HV9120	Load Capacitor	97
HV9121	Charging Resistors	98
HV9122	Wave Front Resistor	98
HV9123	Wave Tail Resistor	98
HV9124	Insulating Rod	98
HV9125	Sphere Gap	98

Product no	Description	page
HV9126-D	Electrical Drive for Sphere Gap	98
HV9127	Load Resistor	98
HV9130	Low Voltage Divider	97
HV9132	Electronic Trigger Sphere	97
HV9133	Measuring Spark Gap	102
HV9134	Vessel for Vacuum/ and Pressure	101
HV9135	Corona Cage	102
HV9137	Oil Testing Cup	103
HV9138	Top Electrode	99
HV9139	Electrode 200	
HV9140	Electrode 300	99
HV9141	Measuring Capacitor/100	97
HV9142	Measuring Capacitor/200	100
HV9143	Measuring Capacitor/300	100
HV9145	Compensating Reactor	
HV9160-PD	Partial Discharge Meter	106
HV9170	Test Object Package	104
HV9191	Component Stand	105
HV-CAGE 1	Safety Cage for Stage 1	88
HV-Inst	Installation and Training	87
LEY500590	Safety Jumpers, black, Set of 10 pcs, 4mm	222
MAT220118	Digital Multimeter	214
MAT220350	Digital Clamp Meter AC / DC current	211
MAT220575	Handscope 20MHz incl. software	213
Mavowatt 4	Wattmeter	212
MT0415	Compressor	222
MT3004E	Strain Gauge Bridge, 220 V, 50 Hz	191
MT3005	Twist and Bend Test Machine Set	190
MT3007	Bending Test Set for MT3017 incl. test peices	195
MT3012E	Fatigue Testing Machine, 220 V, 50 Hz	192
MT3016	Impact Tester	193
MT3017	Tensile and Brinell Test Machine	194
MT3017-51	Compression Test Rods 5 mm, steel 5 pcs	196
MT3017-52	Compression Test Rods 5 mm, aluminum, 5 pcs	196
MT3017-53	Compression Test Rods 5 mm, brass, 5 pcs	196
MT3017-54	Compression Test Rods 5 mm, copper, 5 pcs	196
MT3018-1	Tensile set 5 pcs / steel diam. 5 mm	196
MT3018-2	Tensile set 5 pcs/aluminum diam. 5 mm	196
MT3018-3	Tensile set 5 pcs / brass diam. 5 mm	196
MT3018-4	Tensile set 5 pcs / copper diam. 5 mm	196
MT3019-1	Brinell Test Piece steel 5 pcs	196
MT3019-2	Brinell Test Piece aluminum 5 pcs	196
MT3019-3	Brinell Test Piece m brass 5 pcs	196
MT3019-4	Brinell Test Piece copper 5 pcs	196
MT3026-1	Fatigue Test Piece, (5 pcs), 0,5 mm/4u	192
MT3026-2	Fatigue Test Piece, (5 pcs), 2 mm/4u	192

Product number Index

Product no	Description	page
MT3026-3	Fatigue Test Piece, (5 pcs), 2 mm/25u	192
MT3027-1	Impact testpiece (construction steel) 5 pcs	193
MT3027-2	Impact testpiece (engineering steel) 5 pcs	193
MT3027-3	Impact Test Piece (tooling steel) 5 pcs	193
MT3037-2	Clamping Jaws for test of thin material (Material not incl.)	196
MT3037-3	Compression Test Set incl. Holders and Test Rods	196
MT3047	PC Measuring Device for MT 3017	195
MTH600	Brinell Hardness Tester	197
MV1003	Mobile Test Bench	220
MV1004	Machine Bed	58
MV1006-225	DC-Machine 1 kW 220 V 50 Hz	48
MV1007-405	Induction Motor slip-ring 1.1kW 400/230V 50-60Hz 1.1kW	48
MV1008-235	Synchronous Machine, 230 V Y 50 Hz 1.2 kVA x 0.8	49
MV1009-385	Induction Motor Squirrel Cage	49
MV1009-405	Induction Motor Squirrel Cage, 400/230V 50-60 Hz 1,1 kW	49
MV1010	Flywheel	57
MV1015	Reluctance Motor	54
MV1017	Induction Dalander Motor	54
MV1018	Universal Motor	55
MV1020	Induction Motor Capacitor Start	55
MV1024	DC-Tachogenerator incl. Cover, trim potentiometer incl.	201
MV1027	Synchronous Machine (sailent poles)	55
MV1028-225	DC-Machine, 2.2 kW complete with interpoles 220V	48
MV1029	Protective Cover	201
MV1030	Induction Motor 2 speed, 2 Windings	56
MV1031	Induction Motor	56
MV1032	Thermal Relay	57
MV1037	Induction Motor Cap. Start and Run	56
MV1047	Asynchronous Motor 3-phase Demo Set	57
MV1054	Digital Torque-, Speed- and Shaft Power Meter	50
MV1055	Spacer Shaft	150,221
MV1100-235	Load Resistor 3-ph 3.3 kW	204
MV1101	Load Reactor, 3-phase, 2.5 kVA	204
MV1102	Load Capacitor, three-phase 2.8 kVA	204
MV1103	Variable Transformer, 3-phase	200
MV1107	Load Reactor, 3-ph, 3 kVA	204
MV1300-405	Power Pack 3-ph, supply 400 V, out 230 V	200
MV1400	Push Button Panel	218
MV1417	Terminal Board	218
MV1420	Line Model 3-phase, 230V	73
MV1424	Line Model, 3-ph, 400V, one phi-link (40kV, 40km)	74
MV1425	Line Model, 3-ph, 400, double phi-link (220kV, 100km)	74
MV1429	Connection Box / Terminal Board	218
MV1429	Terminal Board	218
MV1438	Cable Line Model 400V, 3-phase (11kV, 5km)	75
MV1439-235	Power Factor Control Unit	67
MV1450	Line Multi Protection Trainer	81
MV1450-COMP	PC with installed & pre-programmed software for MV1450	81

Product number Index

Product no	Description	page
MV1455	Differential Relay Module	83
MV1455-COMP	PC with installed & preprogrammed software for MV1455	83
MV1500	Load Switch, 3-pole 16A	58
MV1500	Load Switch, 3-pole 16A	58,218
MV1502	Reversing Switch	58
MV1505	Dahlander Switch	54
MV1503	Star-Delta Starter for 3-ph Machines	58
MV1600	Installation Kit, PVC Conduit	116
MV1601	Installation Kit Surface Wiring	117
MV1603	Installation Kit, 3-ph Motor	118
MV1604	Installation Kit, Light Control	119
MV1605	Assembly Frame	115
MV1606	Assembly Boards, Chipboard, set of three.	115
MV1608	Installation Training Equipment	111
MV1610-2	Distribution Protection Trainer	114
MV1613	Tool Kit, Student, for electrician	121
MV1614	Tool Kit, Workshop	121
MV1628	Induction Motor 3-ph Sq.Cage 50-60 Hz	111
MV1665	Residential Wiring Trainer (Kit)	120
MV1680	Assembly Kit for MV 1608	111
MV1801-H	Flex Set 200 Safety Leads 5 colours	221
MV1830-H	Flex Set 100 Safety Leads 5 colours, Retractable shroud	221
MV1830-HF	Flex Set, 100 Safety Leads, Safety Plugs	221
MV1903-235	Synchronizing Device 220-240 V 50-60 Hz	58
MV1904	Flex Stand	222
MV1905	Shunt Regulator	57
MV1911	Transformer 1-phase, 1kVA, 50-60 Hz	78
MV1915	Transformer, 3-ph 2 kVA 50-60 Hz	78
MV1915-C	Transformer 3-phase, sectioned	79
MV1922/23	Ammeter 0-10A, AC/DC	214
MV1926	Voltmeter 0-50-250-500V AC/DC	214
MV1929	Power Factor Meter 3-ph, 0-5A, 230V	215
MV1931	Current Transformer	219
MV1937	Wattmeter 1-ph, 1-5A; 50-250-500V AC/DC	215
MV1939	AC Power Energy Meter	210
MV1941	DC Measuring Unit	210
MV1942	Measuring Module	52
MV1943	Measuring and Control Module	52,28
MV1955	Rheostat 100 W 100 Ohm 1 A	206
MV1957	Rheostat 200W, 5 ohm, 6.3A	206
MV1959	Rheostat 200W, 50 ohm., 2A	206
MV1972	Transformer 3-Phase 400V	79
MV1974	Voltmeter, moving coil 0 - +/- 300 V	211
MV1976	Power Factor Meter 3-ph, 0-5A, 400V	215
MV2221	Line Model 400V 3-phase (230kV, 100km)	76
MV2222	Line Model 400V, 3-phase (11kV, 5km)	76
MV2225	Petersen Coil, Multi Terminal	76
MV2609	Control and Data Aquisition Software	53,209
MV2636	Starter AC- and DC-Motors, Classic	205
MV2658	MOSFET - PWM Module	53,201

Product number Index

Product no	Description	page
MV2661	AC-Control	66,152
MV4206-1	AC Motor Drive	65,151
MV4207-1	DC-Drive	63,148
MV4207-3	DC-Drive, Three-Phase supply	64,149
MV4250	Asynchronous Wind Mill System incl. HVDC Light Line	69
MAT220020	Analogue Multimeter, moving coil	213
Phase Cop 2	Phase Sequence Indicator	212
PRG302200	PID-Future Program Software	154
PRG302500	Programme Software Sigma Win for AC Servo	163
PST2210-IED1	Power Plant Module, IED Level 1	8
PST2210-IED2	Power Plant Module, IED Level 2	8
PST2210-IED3	Power Plant Module, IED Level 3	8
PST2212	Mobile Additional Generator Module	17
PST2221	Transmission Lines Module	11
PST2222	Distribution Lines Module	14
PST2230-IED1	Receiving Substation Module, IED Level 1	12
PST2230-IED2	Receiving Substation Module, IED Level 2	12
PST2230-IED3	Receiving Substation Module, IED Level 3	12
PST2231	Power Grid Switchgear Module	19
PST2240	Load Module	15
PST2250-150	Terco SCADA System Master Module, 3 screen solution	24
PST2252-1	Terco SCADA System Student Module, 1 screen solution	26
PST2280	Power Factor Control Unit	16
PST2290	Wind Power Module	23
PST2291	Solar Power Module	21
PST-Inst 1	Installation and Basic Teacher Training	27
PTG1305	Mobil Motor / Generator Module	35
PTG1439-405	Power Factor Control Module	43
PTG1450	Line Multi Protection Trainer	39
PTG1455	Differential Relay Trainer	40
PTG1521	Transmission HV OH Line 230 kV, 100 km	38
PTG1522	Transmission Cable MV Line 11 kV, 5 km	38
PTG1523	Transmission MV OH Line 35 kV, 20 km	38
PTG1560	Resistive Load Module 400 V, 1,5 kW in 15 steps	41
PTG1561	Inductive Load Module 400V, 2,5 kVAr in 15 steps	41
PTG1562	Capacitor Load Module 400 V, 2,8 kVAr, in 15 steps	41
PTG1565	Double Bus bar Module with 4 feeders	42
PTG1570	Fault Connection Module	42
PTG1631	SCADA System Module	46
PTG1939	AC Power Energy Meter	37
PTG1965	Transformer Module	37
PTG2290	Wind Mill Module	45
PTG2291	Solar Power Module	44
STO170000	Lab Flex Set	221
XDO2040	Digital Oscilloskop	212
XELE102010	EK 10 A Digital PCB	129
XNO-ELE102110	EK10B Digital Plinth for EK 10A	129

Alphabetical Index

Description	Product no	Page
3-Phase Asynchronous motor with Base Plate	ELK102240	140,142
3-Phase Box for Condensators	ELE102237	140
3-Phase Load Unit Low Voltage	ELE102231	138
3-Phase Motor/Generator Module	ELE102236	139
3-Phase Power Load Unit	ELE102233	139
3-Phase Simulator	ELE102230	138
3-Phase Terminal	ELE102232	139,144
3-Phase Transformer	ELE102234	139
AC Motor Drive	MV4206-1	65,151
AC Power Energy Meter	MV1939	210
AC Power Energy Meter	PTG1939	37
AC Servo Amplifier	AUT302524	163
AC Servo Motor	AUT302522	163
AC-Control	MV2661	66,152
Ammeter 0-10A, AC/DC	MV1922/23	214
Analogue Multimeter, moving coil	MAT220020	213
Assembly Boards, Chipboard, set of three.	MV1606	115
Assembly Frame	MV1605	115
Assembly Kit for MV 1608	MV1680	111
Asynchronous Motor 3-phase Demo Set	MV1047	57
Asynchronous Wind Mill System incl. HVDC Light Line	MV4250	69
AU5900 Mecha-Kit Modular System	AUT300200	176
Automatic Sectional Door Model	AUT309905-M	172
Ball Selection Module	AUT302005	170
Base Unit	FOR102000	182
Base Unit 2000	ELE102000	125,127, 130,138, 144,154, 158,168, 178
Basic Digital Electronics, Laboratory Exercises	BOK112030	128
Basic Electronics Laboratory Exercises	BOK112010	124
Basic Power Electronics, Laboratory Exercises	BOK112050	133
Bending Test Set for MT3017 incl. test peices	MT3007	195
Brinell Hardness Tester	MTH600	197
Brinell Test Piece aluminum 5 pcs	MT3019-2	196
Brinell Test Piece copper 5 pcs	MT3019-4	196
Brinell Test Piece m brass 5 pcs	MT3019-3	196
Brinell Test Piece steel 5 pcs	MT3019-1	196
Cable Line Model 400V, 3-phase (11kV, 5km)	MV1438	75
Capacitor Load Module 400 V, 2,8 kVAr, in 15 steps	PTG1562	41
Car Model with expansion site	FOR102060	186
Cascade Connection Set	HV9105-CON	105
Charging Resistors	HV9121	98
Clamping Jaws for test of thin material (Material not incl.)	MT3037-2	196
Compensating Reactor	HV9145	
Component Set DG1	ELE102065	128
Component Stand	HV9191	105
Compression Test Rods 5 mm, aluminum, 5 pcs	MT3017-52	196

Description	Product no	Page	Description	Product no	Page
Compression Test Rods 5 mm, brass, 5 pcs	MT3017-53	196	Series connection	FOR102101	182
Compression Test Rods 5 mm, copper, 5 pcs	MT3017-54	196	10 Demister	FOR102010	184
Compression Test Rods 5 mm, steel 5 pcs	MT3017-51	196	11 Component Kit	FOR102011	184
Compression Test Set incl. Holders and Test Rods	MT3037-3	196	12 Parallel connection	FOR102002	182
Compressor	MT0415	223	13 CAN-BUS ECU Module	FOR102035	187
Connecting Cup	HV9109	99	14 Inductive Sensor	FOR102004	183
Connecting Rod	HV9108	99	15 Hall Sensor	FOR102005	183
Connection Box / Terminal Board	MV1429	218	16 Relay	FOR102006	183
Contactormodule	AUT302012	145	17 Electronic Power Control PWM	FOR102007	183
Control and Data Acquisition Software	MV2609	53, 209	18 Terminal Board	FOR102008	183
Control Desk	HV9104	99	19 Additional Power Supply	FOR102009	184
Control Module	AUT302011	145	20 Experiments Book Motor Control	BOK103615	147
Control Technology Basic Laboratories	BOK302205	157	21 Fatigue Test Piece, (5 pcs), 0,5 mm/4u	MT3026-1	192
Corona Cage	HV9135	102	22 Fatigue Test Piece, (5 pcs), 2 mm/25u	MT3026-3	192
Coupling Capacitor	HV1946	100	23 Fatigue Test Piece, (5 pcs), 2 mm/4u	MT3026-2	192
Current Transformer	MV1931	210	24 Fatigue Testing Machine, 220 V, 50 Hz	MT3012E	192
Current Transformer / Earth Leakage Circuit Breaker	ELE102238	140	25 Fault Connection Module	PTG1570	42
Cylinder Module	AUT302003	170	26 Fault Finding Equipment	MV1609	113
Dahlander Switch	MV1505	54	27 Fault Simulator Box, CAN-BUS (ES35)	FOR102052	187
DC Measuring Unit	MV1941	210	28 Flex Set 100 Safety Leads 5 colours, Retractable shroud	MV1830-H	221
DC Servo Motor with Gears	AUT302512	159	29 Flex Set 200 Safety Leads 5 colours	MV1801-H	221
DC Servo Motor without Gears	AUT302502	159	30 Flex Set, 100 Safety Leads, Safety Plugs	MV1830-HF	221
DC-Drive	MV4207-1	63, 148	31 Flex Stand	MV1904	222
DC-Drive Module	ELK102248	144	32 Floor Pedestal	HV9110	99
DC-Drive, Three-Phase supply	MV4207-3	64, 149	33 Flywheel	AUT302504	159
DC-Machine 1 kW 220 V 50 Hz	MV1006-225	48	34 Frequency Converter AC-Drive Module	ELK102246	143
DC-Machine, 2.2 kW complete with interpoles 220V	MV1028-225	48	35 Gear Indicator	FOR102062	186
DC-Motor	ELK102250	143	36 Generator Brake	AUT302506	159
DC-Tachogenerator incl. Cover	MV1024	201	37 Heating Centre	ELE102239	140
Differential Relay Module	MV1455	83	38 High Voltage Connection	HV9106	99
Differential Relay Trainer	PTG1455	40	39 High Voltage Connection	HV9106-3	99
Digital Clamp Meter AC / DC current	MAT220350	211	40 HK 1 Help Function Card	ELE102001	130
Digital Multimeter	MAT220118	214	41 HV Rectifier	HV9111	97
Digital Torque-, Speed- and Shaft Power Meter	MV1054	50	42 I/O-Module with DC Power Supply (Au5591)	AUT300303	
Digital Oscilloskop	XDO2040	212	43 IK AC-Motor	ELE102229	132
Discharge Rod	HV9107	99	44 IK Component Kit	ELE102226	132
Distribution Lines Module	PST2222	14	45 IK DC-Motor	ELE102227	132
Distribution Protection Trainer	MV1610-2	114	46 IK Terminal Board	ELE102219	133
Double Bus bar Module with 4 feeders	PTG1565	42	47 Impact Test Piece (tooling steel) 5 pcs	MT3027-3	193
D-Sub / Sim Module	AUT309908	174	48 Impact Tester	MT3016	193
Earthing Switch	HV9114	99	49 Impact testpiece (construction steel) 5 pcs	MT3027-1	193
EK 10 A Digital PCB	XELE102010	129	50 Impact testpiece (engineering steel) 5 pcs	MT3027-2	193
EK10B Digital Plinth for EK 10A	XNO-ELE102110	129	51 Induction Motor 3-ph Sq.Cage 50-60 Hz	MV1628	111
Electrical Drive for Sphere Gap	HV9126-D	100	52 Induction Dalander Motor	MV1017	54
Electrode 200	HV9139	100	53 Induction Motor	MV1031	56
Electrode 300	HV9140	100	54 Induction Motor 2 speed, 2 Windings	MV1030	56
Electronic Trigger Sphere	HV9132	100	55 Induction Motor Cap. Start and Run	MV1037	56
Elevator Model Elevator	AUT300080	175	56 Induction Motor Capacitor Start	MV1020	55
Energy and Process Control Trainer	EB3000	165			

Alphabetical Index

Description	Product no	Page
Induction Motor slip-ring 1.1kW 400/230V 50-60Hz 1.1kW	MV1007-405	48
Induction Motor Squirrel Cage	MV1009-385	49
Induction Motor Squirrel Cage, 400/230V 50-60 Hz, 1.1kW	MV1009-405	49
Inductive Load Module 400V, 2,5 kVAr in 15 steps	PTG1561	41
Installation and Basic Teacher Training	PST-Inst 1	27
Installation and Training	HV-Inst	87
Installation Kit Surface Wiring	MV1601	117
Installation Kit, 3-ph Motor	MV1603	118
Installation Kit, Light Control	MV1604	119
Installation Kit, PVC Conduit	MV1600	116
Installation Training Equipment	MV1608	111
Instrument panel with expansion site	FOR102059	185
Insulating Rod	HV9124	98
Introduction to PLC	BOK320030	171,175
IQ Works Programming Software for PC	AUT310710	171
IQ Works Programming Software for PC	AUT310710	174
IQ Works Programming Software for PC	AUT310710	174
IQ Works Programming Software for PC	AUT310710	179
Lab Card 1 Resistor	ELE102010	125
Lab Card 2 Capacitors	ELE102020	125
Lab Card 3 Diodes	ELE102030	125
Lab Card 4 Voltage Regulator	ELE102040	126
Lab Card 5 Transistors	ELE102050	126
Lab Card 6 House Alarm	ELE102060	128
Lab Card IK1 Power Regulator	ELE102221	130
Lab Card IK2 Transistors	ELE102222	131
Lab Card IK3 Operational Amplifier	ELE102223	131
Lab Card IK4 Static Converter	ELE102224	131
Lab Card IK5 AD/DA Converter	ELE102225	131
Lab Card IK6 Frequency Converter, AC	ELE102228	132
Lab Flex Set	STO170000	221
Laboratory Exercise Book	BOK300200	180
Lift Model, Laboratory Exercises	BOK110120	175
Line Model 3-phase, 230V	MV1420	73
Line Model 400V 3-phase (230kV, 100km)	MV2221	76
Line Model 400V, 3-phase (11kV, 5km)	MV2222	76
Line Model, 3-ph, 400, double phi-link (220kV, 100km)	MV1425	74
Line Model, 3-ph, 400V, one phi-link (40kV, 40km)	MV1424	74
Line Multi Protection Trainer	MV1450	81
Line Multi Protection Trainer	PTG1450	39
Liquid Tank Model	AUT302102	156
Load Capacitor	HV9120	97
Load Capacitor, three-phase 2.8 kVAr	MV1102	204
Load Module	PST2240	15
Load Reactor, 3-ph, 3 kVAr	MV1107	204
Load Reactor, 3-phase, 2.5 kVAr	MV1101	204
Load Resistor	HV9127	98

Alphabetical Index

Description	Product no	Page
Load Resistor 3-ph 3.3 kW	MV1100-235	204
Load Switch, 3-pole 16A	MV1500	58
Load Switch, 3-pole 16A	MV1500	58,218
Low Voltage Divider	HV9130	97
M2 Socket Module	AUT309906	173
Machine Bed	MV1004	58
Magnetic Powder Brake	ELK102242	143
ME1 Console	AUT309907	173
Merasuring Module	MV1942	52
Measuring and Control Module	MV1943	52,28
Measuring Capacitor/100	HV9141	97
Measuring Capacitor/200	HV9142	100
Measuring Capacitor/300	HV9143	100
Measuring Resistor	HV9113	98
Measuring Spark Gap	HV9133	102
MECHA-Kit, Laboratory Exercises	BOK300202	
MECHA-Kit, Text book	BOK300201	180
Mobil Motor / Generator Module	PTG1305	35
Mobile Additional Generator Module	PST2212	17
Mobile Test Bench	MV1003	220
MOSFET - PWM Module	MV2658	53,201
Motor Model IK7	ELE102220	133
Oil Testing Cup	HV9137	103
Oscilloscope Handscope 20MHz incl. software	MAT220575	213
Parking Sensor	FOR102061	186
Partial Discharge Meter	HV9160-PD	106
PC Measuring Device for MT 3017	MT3047	195
PC with installed & pre-programmed software for MV1450	MV1450-COMP	81
PC with installed & preprogrammed software for MV1455	MV1455-COMP	83
Petersen Coil, Multi Terminal	MV2225	76
PF2 Temperature Regulation Module	AUT302202	155
PF3 Speed Regulation Module	AUT302203	155
PF4 Signal Converter PF4	AUT302204	156
Phase Sequence Indicator	Phase Cop 2	212
PID Interface PF1	AUT302201	155
PID-Future Program Software	PRG302200	154
PLC Module for Base Unit 2000	AUT302000	146,169, 173,178
PLC mounting profile	AUT302010	175
PLC Programming, Laboratory Exercises	BOK312002	171
Power Factor Control Module	PTG1439-405	43
Power Factor Control Unit	MV1439-235	67
Power Factor Control Unit	PST2280	16
Power Factor Meter 3-ph, 0-5A, 230V	MV1929	215
Power Factor Meter 3-ph, 0-5A, 400V	MV1976	215
Power Grid Switchgear Module	PST2231	19
Power Pack 3-ph, supply 400 V, out 230 V	MV1300-405	200

Description	Product no	Page
Power Plant Module, IED Level 1	PST2210-IED1	8
Power Plant Module, IED Level 2	PST2210-IED2	8
Power Plant Module, IED Level 3	PST2210-IED3	8
Process Value Module	AUT302514	161
Programme Software Sigma Win for AC Servo	PRG302500	163
Programming Software GX Works2 Class-Set	AUT310712	146
Protective Cover	MV1029	201
Push Button Panel	MV1400	218
Rain Sensor	FOR102064	187
Receiving Substation Module, IED Level 1	PST2230-IED1	12
Receiving Substation Module, IED Level 2	PST2230-IED2	12
Receiving Substation Module, IED Level 3	PST2230-IED3	12
Regulator Module	AUT302103	156
Reluctance Motor	MV1015	54
Residential Wiring Trainer (Kit)	MV1665	120
Resistive Load Module 400 V, 1,5 kW in 15 steps	PTG1560	41
Reversing Switch	MV1502	58
Rheostat 100 W 100 Ohm 1 A	MV1955	206
Rheostat 200W, 50 ohm., 2A	MV1959	206
Rheostat 200W, 5 ohm, 6.3A	MV1957	206
Rotary Index Table	ELK102252	145
Safety Cage for Stage 1	HV-CAGE 1	88
Safety Jumpers, black, Set of 10 pcs, 4mm	LEY500590	222
SCADA System Module	PTG1631	46
Sensor Set	AUT302210	157
Servo Base Plate with Linear Unit	AUT302500	159
Servo Control, Laboratory Exercise Book	BOK302505	164
Shunt Regulator	MV1905	57
Simulation Module	AUT302001	146,169, 174,179
Smoothing Capacitor/Impulse Capacitor	HV9112	97
Socket Adapter	AUT302008	146,173
Solar Power Module	PST2291	21
Solar Power Module	PTG2291	44
Spacer Shaft	MV1055	150,221
Spacer Tube	HV9119	99
Sphere Gap	HV9125	98
SR1 Servo Regulator	AUT302508	160
SR2 Speed Regulation Module	AUT302510	160
SR3 Positioning Module	AUT302516	161
Star-Delta Starter for 3-ph Machines	MV1503	58
Starter AC- and DC-Motors, Classic	MV2636	205
Stepper Motor	AUT302518	162
Stepper Motor Module SM1	AUT302520	162
Storage Rack 1 row	ELE02002	219
Storage Rack 1 row	ELE102002	219
Storage Rack 2 row	ELE102004	219
Strain Gauge Bridge, 220 V, 50 Hz	MT3004E	191
Synchronizing Device 220-240 V 50-60 Hz	MV1903-235	58

Alphabetical Index

Description	Product no	Page
Synchronous Machine, 230 V Y 50 Hz 1.2 kVA x 0.8	MV1008-235	49
Synchronous Machine (sailent poles)	MV1027	55
Table with wheel for Energy Bench	ELE309902	165
Tachometer - RPM-Meter	ELK102244	143
Tensile and Brinell Test Machine	MT3017	194
Tensile set 5 pcs / brass diam. 5 mm	MT3018-3	196
Tensile set 5 pcs / copper diam. 5 mm	MT3018-4	196
Tensile set 5 pcs / steel diam. 5 mm	MT3018-1	196
Tensile set 5 pcs/aluminum diam. 5 mm	MT3018-2	196
Terco SCADA System Student Module, 1 screen solution	PST2252-1	26
Terco SCADA System Master Module, 3 screen solution	PST2250-150	24
Thermal Relay	MV1032	57
Terminal Block Module	AUT302004	170,179
Terminal Board	MV1417	218
Terminal Board	MV1429	218
Test Object Package	HV9170	104
Test Transformer 100kV	HV9105	96
Theory Book Servo Techniques	BOK302500	164
Three-Phase AC, Laboratory Exercises	BOK102212	137
Tool Kit, Student, for electrician	MV1613	121
Tool Kit, Workshop	MV1614	121
Top Electrode	HV9138	99
Touch Sensor	FOR102063	186
Traffic Lights Module	AUT302002	169,179
Transformer 1-phase, 1kVA, 50-60 Hz	MV1911	78
Transformer 3-Phase 400V	MV1972	79
Transformer 3-phase, sectioned	MV1915-C	79
Transformer Module	PTG1965	37
Transformer, 3-ph 2 kVA 50-60 Hz	MV1915	78
Transmission Cable MV Line 11 kV, 5 km	PTG1522	38
Transmission HV OH Line 230 kV, 100 km	PTG1521	38
Transmission Lines Module	PST2221	11
Transmission MV OH Line 35 kV, 20 km	PTG1523	38
Twist and Bend Test Machine Set	MT3005	190
Variable Transformer, 3-phase	MV1103	200
Wattmeter	Mavowatt 4	212
Wattmeter 1-ph, 1-5A; 50-250-500V AC/DC	MV1937	215
Wave Front Resistor	HV9122	98
Wave Tail Resistor	HV9123	98
Vessel for Vacuum/ and Pressure	HV9134	101
Wind Mill Module	PTG2290	45
Wind Power Module	PST2290	23
Voltmeter 0-50-250-500V AC/DC	MV1926	214
Voltmeter, moving coil 0 - +/- 300 V	MV1974	211